

# Master Part Manual

## Skid Steer Loader

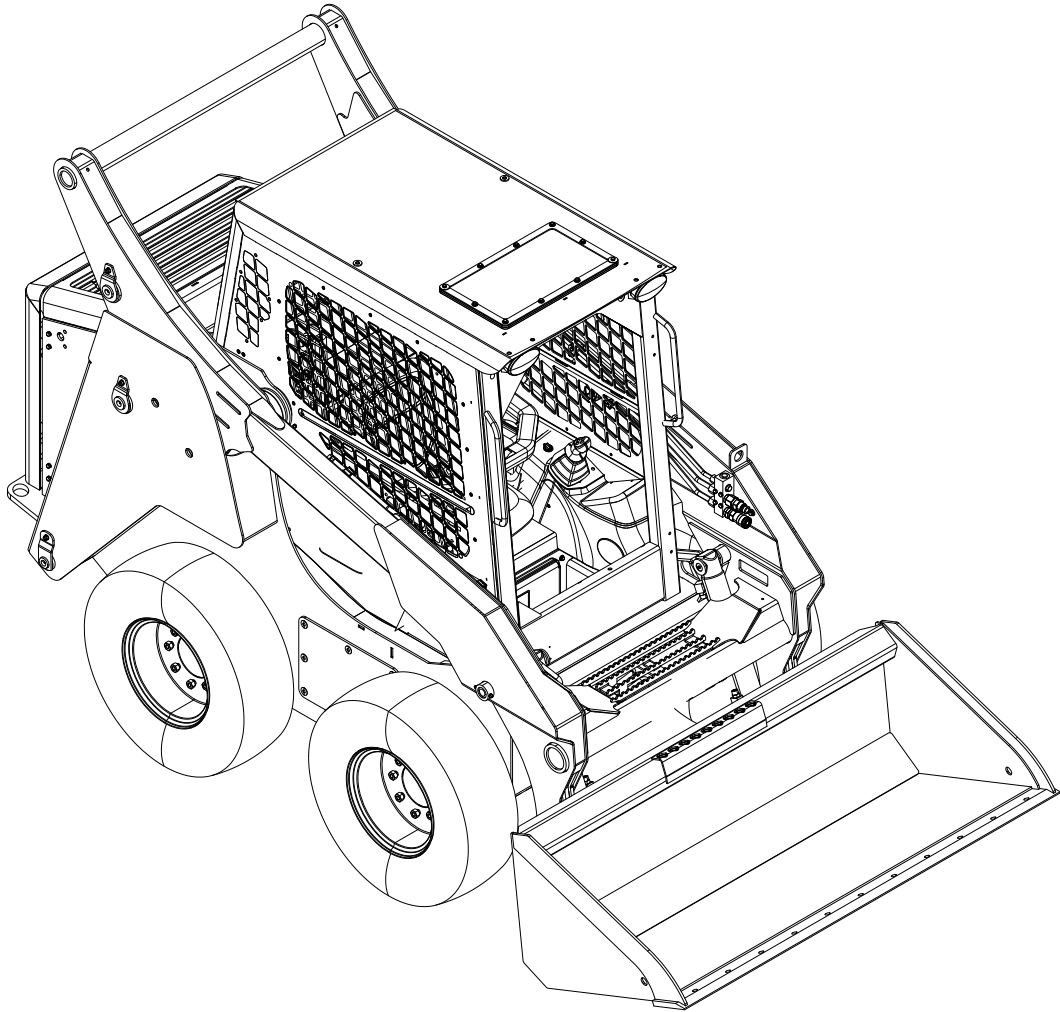

**VS-60**  
**V230S**

Printed 2/06/2020

# Table of Contents

1. **Service Parts**
  - 1-1 Service Items / Lubricants
  - 1-2 Component Service Items / Harnesses
  - 1-3 Harnesses
2. **Fuel/Engine**
  - 2-1 Engine / Intake-exhaust / Battery
  - 2-2 Cooling System
3. **Hydraulic Components**
  - 3-1 Hydraulic Reservoir
  - 3-2 Lift Arm Control Valve
  - 3-3 Pilot Generation / Control Blocks
  - 3-4 Hydraulic Cylinders / Lift Arm Assembly
  - 3-5 Auxiliary Lift Arm Tubes
  - 3-6 Hydraulic Control Assembly- Single Speed
  - 3-7 Hydraulic Control Assembly- Two Speed
  - 3-8 Hydraulic Drive / Auxiliary
4. **Electrical**
  - 4-1 Fuse Panel
5. **Undercarriage**
  - 5-1 Final Drive Assembly RT
  - 5-2 Final Drive Assembly LT
6. **Mainframe**
  - 6-1 Chassis / Fuel Tank
  - 6-2 Hood Assembly
7. **Cab / Heating / Air Conditioning**
  - 7-1 Cab
  - 7-2 Cab Interior
  - 7-3 Headliner / Dash
  - 7-4 Door / Windows
  - 7-5 Wiper
  - 7-6 Heater (optional)
  - 7-7 HVAC (optional)
  - 7-8 Air Conditioning / Heating Unit (optional)
8. **Working Equipment**
  - 8-1 Quick Attach- Manual
  - 8-2 Quick Attach- Power
9. **Graphics / Safety Decals**
  - 9-1 ANSI Safety Decals
  - 9-2 ISO Safety Decals
  - 9-3 ASV Graphics
  - 9-4 TEREX Graphics
10. **Kits**
  - 10-1 Kits

\* Parts manuals are updated on a regular basis. Always refer to current online posted manuals to ensure you have the most up to date information prior to ordering parts.

**NOTE:** Ordering parts that are painted requires a specific part number format. Please refer to page II of this manual for paint code and ordering

## Painted Service Parts

### ordering guidelines

Compact Track and Skid Steer Loaders are available in various colors and nomenclatures (brands / model names).

**Paint color needs to be specified when ordering painted components.** When ordering painted components, inform the support representative of the brand and model name of your machine before selecting the proper color from the list below. The support representative should be able to assist you in finding the correct one based on your machine's **VIN number**. This should help to identify the original machine configuration and nomenclature.

**Note:** Not all colors are available on all components. Available colors are limited to those considered "standard" on your particular machine and component(s). Please do not attempt to order non-standard colors for your machine as the order will not be fulfilled until corrected.

The color codes are to be referenced as a suffix to the part number of the component you are requesting, for example: 0000-000-GRN (indicating a green part).

The following is a list of available colors.

<u>Color</u>	<u>Color Code:</u>
BLACK	BLK (ALL MODELS)
WHITE	WHT (TEREX)
YELLOW	YEL (VERMEER)
YELLOW	YEY (ASV)
GREEN	GRN (SUNBELT)
RED	RED (TAKEUCHI)
GRAY	GRY (TEE)
GRAY	GTG (SKID STEER WHEELS ONLY)
ORANGE	ORN (ASPLUNDH)

# Chapter 1

## Service Parts

### 1-1 Service Items / Lubricants

### 1-2 Component Service Items

### 1-3 Harnesses

\* Parts manuals are updated on a regular basis. Always refer to current online posted manuals to ensure you have the most up to date information prior to ordering parts.

## **GENERAL SERVICE ITEMS & LUBRICANTS**

<b><u>ITEM</u></b>	<b><u>DESCRIPTION</u></b>	<b><u>PART NUMBER</u></b>
-Engine Oil Filter	Filter, Engine Oil	0200-377
-Primary Air Filter	Filter, Primary Air	0200-339
-Secondary Air Filter	Filter, Secondary Air	0200-340
-Fuel Filter	Filter, Fuel	0200-213
-Fan Belt	Belt, Fan	2030-632
250 Hour Service Kit	Kit, 250 hr	0404-871
500 Hour Service Kit	Kit, 500 hr	0404-861

## **HYDRAULIC SERVICE ITEMS & LUBRICANTS**

<b><u>ITEM</u></b>	<b><u>DESCRIPTION</u></b>	<b><u>PART NUMBER</u></b>
-Hydraulic Charge Oil Filter	Filter, Hydraulic Charge	0404-161

<b><u>O-RING</u></b>	<b><u>PART NUMBER</u></b>
-# 4, Flat Face Type	2055-196
-# 6, Flat Face Type	0310-285
-# 8, Flat Face Type	0310-286
-# 10, Flat Face Type	0310-287
-# 12, Flat Face Type	0310-288
-# 16, Flat Face Type	0310-289
-# 20, Flat Face Type	0310-290
-# 24, Flat Face Type	0201-479
-# 4, ORB Type	0314-366
-# 6, ORB Type	0310-619
-# 8, ORB Type	0307-353
-# 10, ORB Type	0310-620
-# 12, ORB Type	0310-621
-# 16, ORB Type	0307-354
-# 20, ORB Type	0310-832

# COMPONENT SERVICE ITEMS

## Current Hydraulic Cylinders

- RH-Bucket/Tilt P/N: 7100-451
- RH-Q/A P/N: 2046-317
- LH-Bucket/Tilt P/N: 7100-450
- LH-Q/A P/N: 2046-316
- Lift-Arm P/N: 7001-449

<u>ITEM</u>	<u>MANUFACTURER/DESCRIPTION</u>	<u>PART NUMBER</u>
-Kit,Seal,Bucket/Tilt Cylinder	Fits Cylinder (P/N:7100-450/451)	0404-536
-Nut,Bucket/Tilt Cylinder	Fits Cylinder (P/N:7100-450/451)	2076-159
-Bushing,Tube Pivot	Fits Cylinder (P/N:7100-450/451)	7000-802
-Bushing,Rod Pivot	Fits Cylinder (P/N:7100-450/451)	0003-053
-Kit,Seal,Lift Arm Cylinder	Fits Cylinder (P/N:7001-449)	0404-537
-Rod,Lift Arm Cylinder	Fits Cylinder (P/N:7001-449)	7000-660
-End Gland,Lift Arm Cylinder	Fits Cylinder (P/N:7001-449)	7100-149
-Nut,Lift Arm Cylinder	Fits Cylinder (P/N:7001-449)	2076-159
-Kit,Seal,Q/A Cylinder	Fits Cylinder (P/N:2046-316/317)	2076-292

## DRIVE MOTORS

<u>ITEM</u>	<u>MANUFACTURER/DESCRIPTION</u>	<u>PART NUMBER</u>
-Kit, Seal, Drive Motor	MCR3 Drive Motor (P/N:7001-487)	7001-488
-Kit, Seal, Drive Motor	MCR3 Drive Motor (P/N:7001-485)	7001-486

# HARNESSES

**VS-60 Serial # 00500-00505**  
**V230S Serial # 00101-00517**

<b><u>ITEM</u></b>	<b><u>LOCATION</u></b>	<b><u>PART NUMBER</u></b>
Left Pillar Harness	Cab Interior, Left Side	7005-968
Right Pillar Harness	Cab Interior, Right Side	7005-967
Main Harness	Chassis (throughout machine)	7005-969
Loader Harness	Lift Arm	7000-117
Condenser Harness	Rear of Cab, A/C Fans	2076-034
Rear Lights Harness	Rear Hood, Lights	7005-619
4 Unit Gauge Harness	Dash Panel	7005-882

**VS-60 Serial # 00506-00745**  
**V230S Serial # 00517-00745**

<b><u>ITEM</u></b>	<b><u>LOCATION</u></b>	<b><u>PART NUMBER</u></b>
Left Pillar Harness	Cab Interior, Left Side	7005-968
Right Pillar Harness	Cab Interior, Right Side	7005-967
Main Harness	Chassis (throughout machine)	7005-969
Loader Harness	Lift Arm	7000-117
Condenser Harness	Rear of Cab, A/C Fans	2076-034
Rear Lights Harness	Rear Hood, Lights	7005-619
3 Unit Gauge Harness	Dash Panel	7001-479

**VS-60 Serial # valid from: 00746**  
**V230S Serial # Valid From: 00746**

<b><u>ITEM</u></b>	<b><u>LOCATION</u></b>	<b><u>PART NUMBER</u></b>
Left Pillar Harness	Cab Interior, Left Side	7005-968
Right Pillar Harness	Cab Interior, Right Side	7005-967
Main Harness	Chassis (throughout machine)	7005-969
Loader Harness	Lift Arm	7000-117
Condenser Harness	Rear of Cab, A/C Fans	2076-034
Rear Lights Harness	Rear Hood, Lights	7005-619
3 Unit Gauge Harness	Dash Panel	7001-489
Gauge Harness Jumper	Dash Panel	7011-233

## Chapter 2

### Fuel / Engine

#### **2-1 Engine / Intake / Exhaust / Battery**

VS-60 Serial # valid from - 00500 **2-1A**

V230S Serial # valid from - 00101 **2-1A**

#### **2-2 Cooling System**

VS-60 Serial # valid from - 00500 **2-2A**

V230S Serial # valid from - 00101 **2-2A**

**\* Parts manuals are updated on a regular basis. Always refer to current online posted manuals to ensure you have the most up to date information prior to ordering parts.**

**NOTE:** Ordering parts that are painted requires a specific part number format. Please refer to page II of this manual for paint code and ordering information

# ENGINE / INTAKE-EXHAUST / BATTERY

VS-60 Serial # Valid from 00500  
V230S Serial # Valid from 00101

Chapter 2

REF. NO.	PART NUMBER	QTY.	DESCRIPTION	REF. NO.	PART NUMBER	QTY.	DESCRIPTION
1	8102-222	16	CAPSCREW,HH,3/8-16 UNCx1.0,GD8,ZN	41	0300-455	1	CABLE,THROTTLE
2	8051-272	16	WASHER,SPRING LOCK,3/8,ZN	42	0310-465	1	CLAMP,WIRE,5/8,RBC-5/8
3	0304-900	1	MNT,PLATE,PUMP	43	8040-366	2	NUT,HEX,NYLOCK,1/4-20 UNC,ZN
4	8102-132	8	CAPSCREW,HH,5/16-18UNCx1.0 GD8 ,ZN	44	7000-045	1	HOSE INTAKE FORMED 60HP
5	8051-242	17	WASHER,SPRING LOCK,5/16,ZN	45	0200-213	1	FILTER,FUEL,PERKINS,404C22
6	0304-507	1	PLATE,FLYWHEEL 15375 KB42575	46	0300-581	1	W/NUTS,U-BOLT,1/4-20
7	2030-329	1	ENGINE PERKINS 404D-22T	47	7000-199	1	BRACKET THROTTLE
8	7000-058	2	SSL, MF, MOTOR MOUNT, FRONT	48	0304-835	1	BULB,PRIMER
9	0300-458	4	MOUNT,ENGINE	49	0200-351	1	HOSE,FUEL,5/16IDx2.00"
10	0304-948	4	LIMITER,MNT,MOTOR	50	7000-484	1	CABLE BATTERY POSITIVE
11	8040-726	4	NUT,HEX,NYLOCK,5/8-11 UNC,ZN	51	4046-090	1	CABLE BATTERY NEGATIVE
12	0201-897	4	CAPSCREW,5/8-11X2.5 GD8	52	0201-336	1	TERMINAL,BATTERY (DOES NOT INCLUDE ITEM 53)
13	2030-279	1	GUARD RAIN STARTER	53	7000-730	1	BRACKET REMOTE TERMINAL
14	7000-057	2	SSL, MF, MOTOR MOUNT, REAR, RH	54	7000-785	1	CABLE BATTERY POSITIVE
15	2030-632	1	BELT FAN	55	0200-353	1	HOSE,FUEL,5/16IDx30.00"
16	0200-377	1	FILTER,OIL,ENGINE	56	0300-718	2	W/PIN,CLEVIS
17	0200-352	1	HOSE,FUEL,5/16IDx17.00"	57	7000-792	1	HOSE FUEL RETURN
18	0300-732	12	CLAMP,HOSE,#4 MM4	58	2045-777	6	SPRING,TAILPIPE
19	8102-138	1	CAPSCREW,HH,5/16-18 X 2.25 GD8	59	7000-527	1	ASSY HEADER EXHAUST 60 HP
20	0200-338	1	ASSY,FILTER,WATER	60	7000-552	1	WLMT ELBOW MUFFLER TS 60
21	0200-178	1	WLMT,BRKT,MNT,FILTER	61	1066-009	1	FOAM,STRIP,ADHES BACK, 5"
22	0200-329	2	CAPSCREW,HH,M8x1.25x16MM	62	1066-009	1	FOAM,STRIP,ADHES BACK, 11 1/2"
23	0304-509	1	HOSE,FUEL,5/16x22"	63	7000-673	1	VALVE DRAIN OIL
24	7000-090	1	STRAP BATTERY	64	7000-949	1	HOSE OIL DRAIN
25	0090-428	2	CAPSCREW 1/4"-20 x 7", HEX ,GRADE 5,YELLOW ZINC				
26	0200-160	1	BATTERY,50 SERIES				
27	7000-550	1	MUFFLER 60				
28	0200-157	1	ASSY,CLEANER,AIR				
29	0200-313	1	INDICATOR,AIRCLEANER				
30	0200-340	1	FILTER,AIR,SECONDARY				
31	0200-339	1	FILTER,AIR,PRIMARY				
32	0200-560	1	CAP,AIR CLEANER				
33	0304-503	1	VALVE,DUST #P522958				
34	0304-511	1	GASKET,MUFFLER				
35	0300-211	4	CAPSCREW,M8 x 1.25 x 25MM LG				
36	0200-158	1	BAND,MNT,AIR CLEANER				
37	8102-130	7	CAPSCREW,HH 5/16-18x3/4,GR8				
38	8040-426	2	NUT,HEX,NYLOCK,5/16-18 UNC,ZN				
39	0200-215	1	ASSY,FILTER,FUEL				
40	2051-844	1	HOSE FUEL FILTER-ENGINE				

For kit information, please see page 10-1A

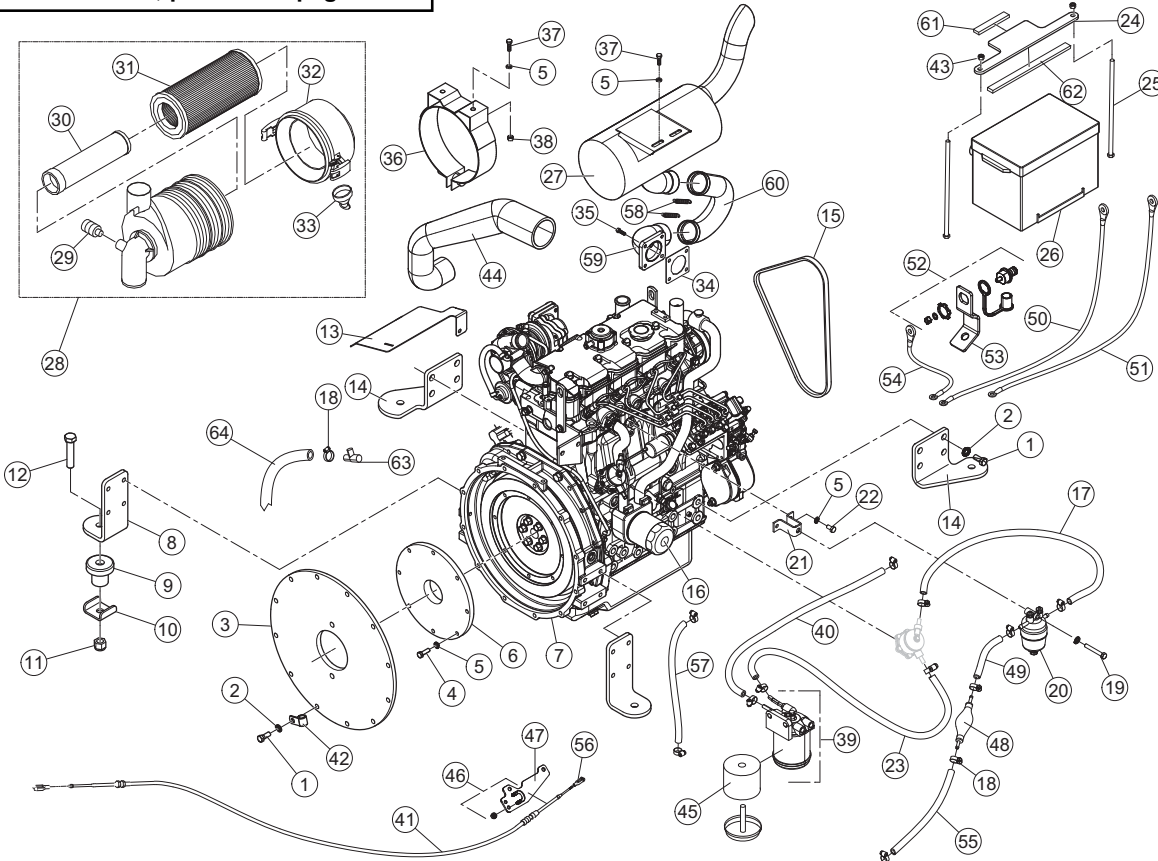

# COOLING SYSTEM

VS-60 Serial # Valid from 00500  
V230S Serial # Valid from 00101

Chapter 2

REF. NO.	PART NUMBER	QTY.	DESCRIPTION	REF. NO.	PART NUMBER	QTY.	DESCRIPTION
1	7000-080	1	SSL,MF,COOLER	41	7000-133	1	TUBE COOLANT LOWER ENGINE
2	0304-444	1	HOSE,7/16 x 5/16 POLY,3FT	42	7001-379	1	HOSE 1.25" ID 3" WATER PUMP MF SSL
3	7000-281	1	SHROUD,RADIATOR	43	0090-481	1	SEAL, EDGE W/ 3/16 BULB x 28"
4	7000-278	1	GUARD FAN FRONT	44	0090-688	1	BOLT SHOULDER 3/8" x 1/2" x 5/16"-18
5	7000-280	1	WLMT,GUARD,FAN	45	0090-462	1	CLIP, HAIRPIN 3/8" X 1-1/4"
6	0200-152	1	SPACER,FAN,3024C	46	0090-104	1	WASHER .402 x .728 x .098 HARD
7	7000-343	1	FAN,17.5/8-8/35/PAG (SEE NOTE)	47	7001-217	1	ROD PROP SLOTTED
8	7000-105	1	CAGE FINGER GUARD REAR	48	7001-435	1	SPACER DOOR LATCH SSL
9	8102-132	22	CAPSCREW,HH,5/16-18UNCx1.0 GD8 ,ZN	49	7000-962	1	WLMT LATCH CHASSIS
10	8051-242	30	WASHER,SPRING LOCK,5/16,ZN	50	8102-239	2	CAPSCREW,HH, 3/8-16UNCx6.5,GD8,ZN
11	8050-262	30	WASHER,WROUGHT,5/16,STD,ZN	51	0314-269	2	NUT,FLANGE,TOPLK,3/8-16UNC,GDG,ZN
12	8102-134	2	CAPSCREW,HH,5/16-18UNCx1.25GD8 ZN	52	0303-238	5	CLAMP, HOSE
13	8051-332	2	WASHER,SPRING LOCK,1/2,ZN				
14	8102-405	2	CAPSCREW,HH,1/2-13 UNCx1.5,GD8				
15	8102-040	4	CAPSCREW,HH,1/4-20 UNCx.75,GD8 ZN				
16	0300-732	1	CLAMP,HOSE,#4 MM4				
17	8102-222	2	CAPSCREW,HH,3/8-16 UNCx1.0,GD8,ZN				
18	7000-733	1	HOSE RADIATOR LOWER				
19	0090-449	3	CLAMP,HOSE				
20	7001-411	1	HOSE 16. HYD OIL COOLER TO FILTER 62.5"				
21	7000-732	1	HOSE RADIATOR UPPER				
22	7000-731	1	HOSE COOLER UPPER				
23	0310-343	1	ADAPTER,16MFFOR-16MB-90^				
24	7000-548	2	BRACKET COOLER MOUNT				
25	8102-418	2	CAPSCREW,HH,1/2-13UNCx 6.0,GD8,ZN				
26	8050-348	4	WASHER,1/2,SAE,ZN 1.06 OD x .531 ID x .0				
27	7000-108	4	BUSHING				
28	7000-780	2	SPACER TUBE				
29	7000-537	2	BRACKET HINGE				
30	8040-606	2	NUT,HEX,NYLOCK,1/2-13 UNC,ZN				
31	8040-426	6	NUT,HEX,NYLOCK,5/16-18 UNC,ZN				
32	0200-336	4	CAPSCREW,HH,M6x1.0x40				
33	8102-224	4	CAPSCREW,HH,3/8-16UNCx1.25,GD8,ZN				
34	8051-272	4	WASHER,SPRING LOCK,3/8,ZN				
35	7001-456	2	SLEEVE, HEAT 3.25" x 26"				
36	7000-975	1	WLMT FRAME MOUNT FINGER GUARD				
37	7000-972	1	WLMT BRACKET FAN GUARD ADJ				
38	2095-899	1	CAP RADIATOR				
39	8102-130	4	CAPSCREW,HH 5/16-18x3/4,GR8				
40	7000-110	1	BRACE FAN SHROUD				

For kit information, please see page 10-1A

**NOTE:** Item 7, 7000-343 Fan, MUST be purchased as a complete assembly only and cannot be purchased as individual components.

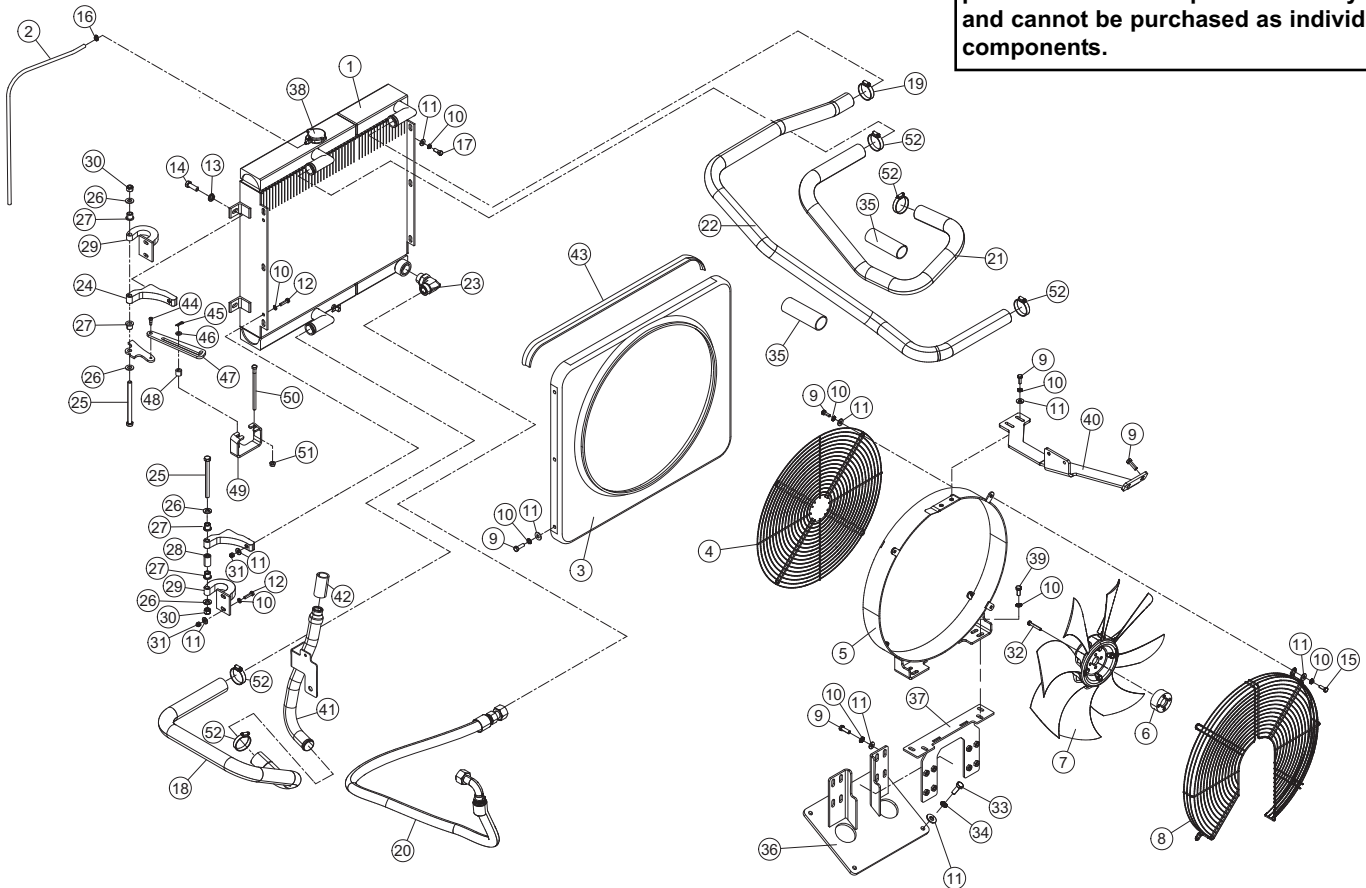

# Chapter 3

## Hydraulic Components

### **3-1 Hydraulic Reservoir**

VS-60 Serial # valid from - 00500 **3-1A**

V230S Serial # valid from - 00101 **3-1A**

### **3-2 Lift Arm Control Valve**

VS-60 Serial # valid from - 00500 **3-2A**

V230S Serial # valid from - 00101 **3-2A**

### **3-3 Pilot Generation / Control Blocks**

VS-60 Serial # valid from - 00500 **3-3A**

V230S Serial # valid from - 00101 **3-3A**

### **3-4 Hyd. Cylinders- Lift Arm Assembly**

V230S Serial # 00101 - 00465. . . **3-4A**

VS-60 Serial # 00500 - 00500. . . **3-4B**

V230S Serial # 00466 - 00513. . . **3-4B**

VS-60 Serial # Valid from - 00501 **3-4C**

V230S Serial # Valid from - 00514 **3-4C**

### **3-5 Lift Arm Tubes / Fittings**

VS-60 Serial # valid from - 00500 **3-5A**

V230S Serial # valid from - 00101 **3-5A**

### **3-6 Hydraulic Control - Single Speed**

VS-60 Serial # valid from - 00500 **3-6A**

V230S Serial # valid from - 00101 **3-6A**

### **3-7 Hydraulic Control - Two Speed**

VS-60 Serial # valid from - 00500 **3-7A**

V230S Serial # valid from - 00101 **3-7A**

### **3-8 Hydraulic Drive / Auxiliary**

VS-60 Serial # 00500 - 00510 **3-8A**

V230S Serial # 00101 - 00511 **3-8A**

VS-60 Serial # valid from - 00511 **3-8B**

V230S Serial # valid from - 00512 **3-8B**

**\* Parts manuals are updated on a regular basis. Always refer to current online posted manuals to ensure you have the most up to date information prior to ordering parts.**

**NOTE:** Ordering parts that are painted requires a specific part number format. Please refer to page II of this manual for paint code and ordering information

# HYDRAULIC RESERVOIR ASSEMBLY

VS-60 Serial # Valid from 00500  
V230S Serial # Valid from 00101

Chapter 3

REF. NO.	PART NUMBER	QTY.	DESCRIPTION	REF. NO.	PART NUMBER	QTY.	DESCRIPTION
1	7000-445	1	WLMT TANK HYDRAULIC				
2	0201-151	1	SCREEN,SUCTION,2.5"				
3	0090-336	2	GROMMET 1/2" VINTON LARGE				
4	0090-102	2	ADAPTER INSERT 1/2" 90°				
5	0300-732	2	CLAMP,HOSE,#4 MM4				
6	8102-222	2	CAPSCREW,HH,3/8-16 UNCx1.0,GD8,ZN				
7	8051-272	2	WASHER,SPRING LOCK,3/8,ZN				
8	8050-282	2	WASHER,WROUGHT,3/8,STD,ZN				
9	8102-225	1	CAPSCREW,HH,3/8-16 UNCx1.5,GD8,ZN				
10	0304-452	1	ASSY,COVER,ACCESS				
11	0310-400	2	NUT,WELD,HEX 1/2-13 UNC				
12	0304-642	1	GAUGE,SIGHT 5"				
13	7000-345	1	HYDRAULIC OIL FILL HOSE				
14	2075-992	1	NECK FILLER OIL PLASTIC				
15	7000-346	1	HYD OIL FILL BRKT				
16	0307-879	1	SWITCH,TEMP,OIL,225^				
17	2045-408	1	CAP OIL BLACK				
18	8102-042	3	CAPSCREW, HH 1/4-20UNC 1" GD8				
19	8051-212	3	WASHER,SPRING LOCK,1/4,ZN				
20	8040-366	3	NUT,HEX,NYLOCK,1/4-20 UNC,ZN				
21	8051-242	2	WASHER,SPRING LOCK,5/16,ZN				
22	8102-129	2	CAPSCREW,HH,5/16-18UNCx5/8, GR				
23	0310-338	1	ADAPTER,CAP,8FFOR 8FNL-S24				
24	0310-337	2	ADAPTER,CAP,6FFOR 6V9829(FS0304-C-06)25				
25	0310-557	1	ADAPTER,6MFFOR-4MB-90				
26	0201-314	1	ADAPTER,FS6801-04-04-NW0				
27	8050-222	4	WASHER,WROUGHT,1/4,STD,ZN				
28	7000-803	2	PLATE PILOT SANDWICH				
29	1066-009	2	FOAM STRIP,ADHES BACK, 3/4"				
30	0201-628	4	SPACER,CLAMP				

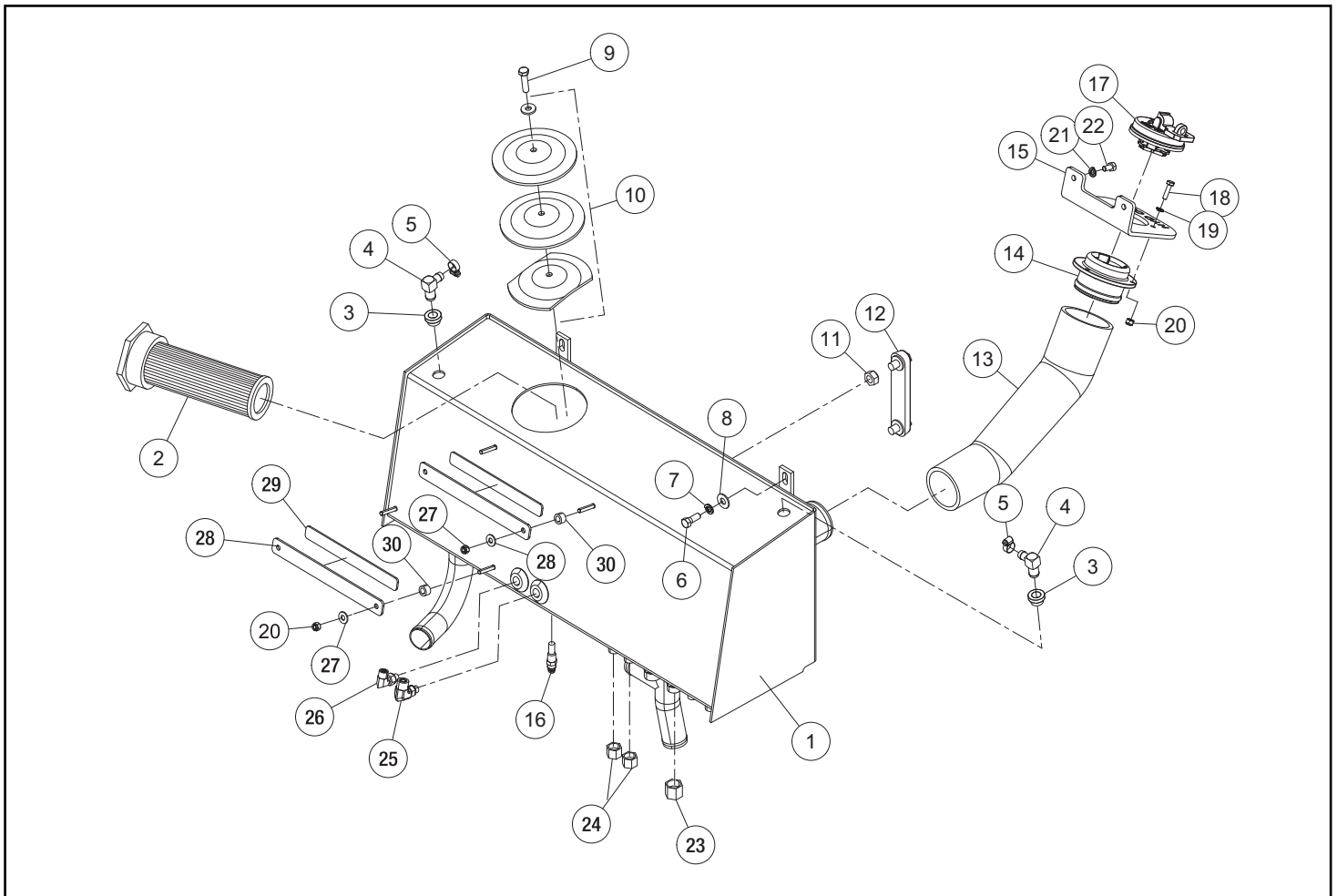

# LIFT ARM CONTROL VALVE ASSEMBLY

VS-60 Serial # Valid from 00500  
V230S Serial # Valid from 00101

Chapter 3

REF. NO.	PART NUMBER	QTY.	DESCRIPTION	REF. NO.	PART NUMBER	QTY.	DESCRIPTION
1	3030-395	1	VALVE LOADER 9610				
2	0310-321	1	ADAPTER,12MFFOR-12MB90				
3	0201-314	3	ADAPTER,FS6801-04-04-NW0				
4	0310-318	4	ADAPTER,10MFFOR-10MB				
5	0310-332	2	ADAPTER,10MFFOR-12MB				
6	0310-329	1	ADAPTER,6MFFOR-6MB				
7	0310-324	1	ADAPTER,16MFFOR-12MB-90				
8	7001-141	2	ADAPTER,4MFFOR-4MB-45				
9	7000-623	1	RELIEF VALVE				
10	0404-423	2	SOLENOID CARTRIDGE VALVE				

For kit information, please see page 10-1A

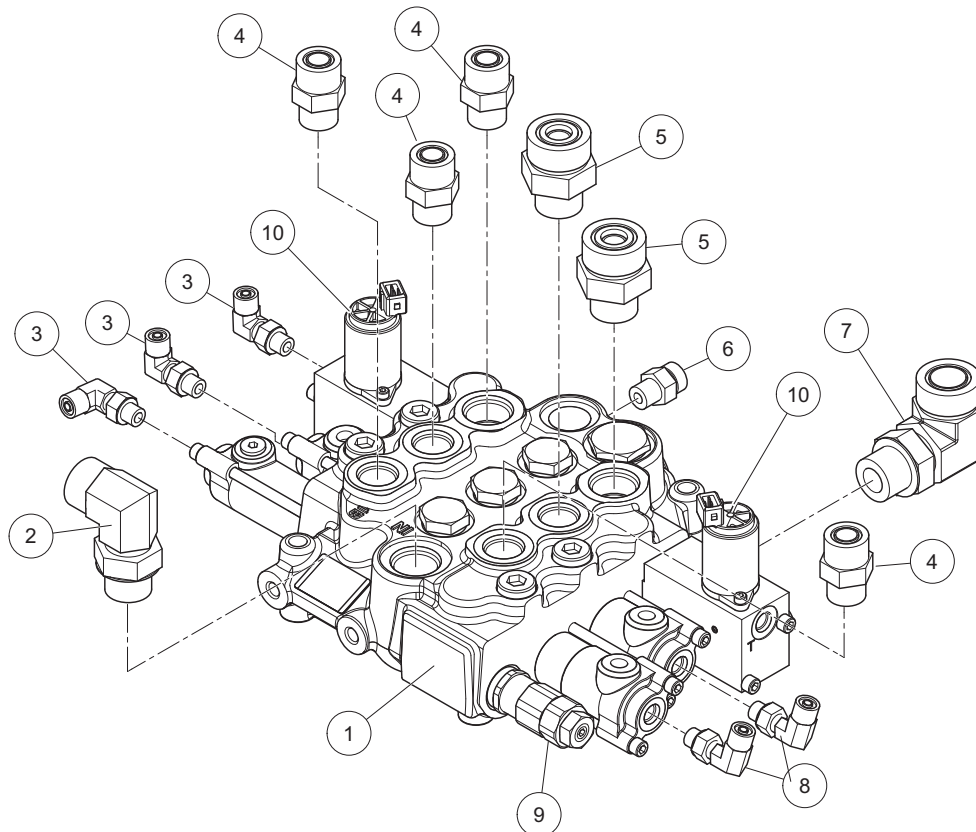

# PILOT GEN / CONTROL BLOCKS

VS-60 Serial # Valid from 00500  
V230S Serial # Valid from 00101

Chapter 3

REF. NO.	PART NUMBER	QTY.	DESCRIPTION
1	7000-294	1	ASSY VALVE BOOM MANUAL
2	0310-345	1	ADAPTER,8MFFOR-8MB
3	7000-471	1	ADAPTER 6MFFOR 8MB 90^
4	2051-615	1	BLOCK CONTROL
5	0310-329	7	ADAPTER,6MFFOR-6MB
6	0201-309	1	ADAPTER,FS6400-04-06-0
7	0200-364	1	COIL SOLENIOD 2 SPEED HYDRAULIC QA
8	7005-675	1	MANIFOLD PILOT GENERATION SIZE 6
9	2051-840	1	CARTRIDGE SOLENIOD 2 SPEED
10	7000-625	3	COIL PILOT GEN BLOCK
11	7000-624	3	CARTRIDGE PILOT GEN BLOCK
12	7000-293	1	PLUNGER VALVE
13	7000-295	1	BLOCK VALVE

REF. NO.	PART NUMBER	QTY.	DESCRIPTION

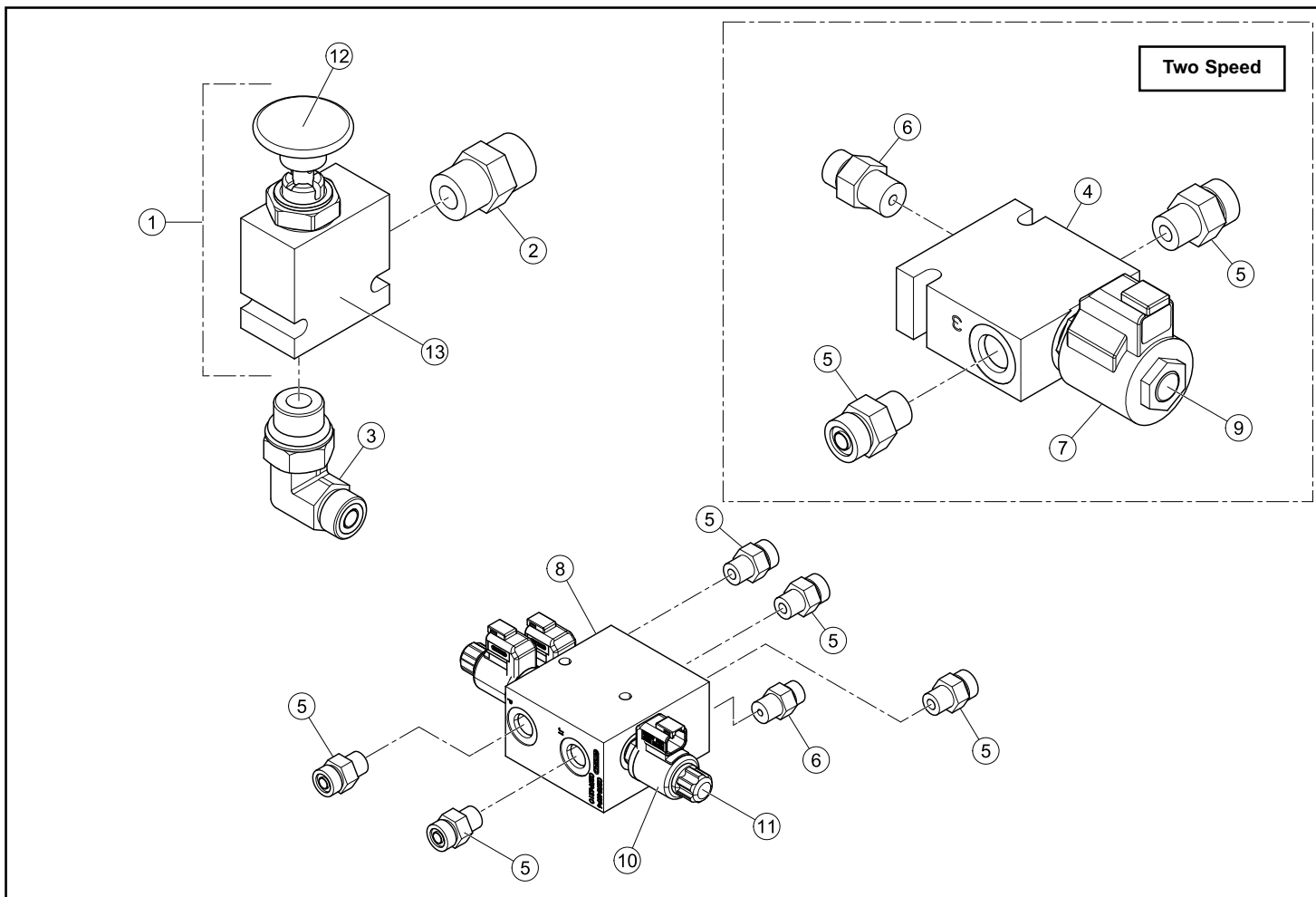

# HYD. CYLINDERS / LIFT ARM ASSEMBLY

V230S Serial # 00101-00465

Chapter 3

REF. NO.	PART NUMBER	QTY.	DESCRIPTION	REF. NO.	PART NUMBER	QTY.	DESCRIPTION
1	0314-269	12	NUT,FLANGE,TOPLK,3/8-16UNC,GDG,ZN	41	2040-325	2	WLMT, PIN, QA TILT,6.00
2	0300-607	12	ZERK,GREASE,1/4-28 1103K21	42	0090-527	4	BOLT 3/8" 25/32" O.D. ZINC PUSHNUT
3	8102-222	4	CAPSCREW,HH,3/8-16 UNCx1.0,GD8,ZN	43	0090-562	4	PLUG TREE STYLE 1" HEAD X 0.42 X 1.2
4	7001-052	2	PIN				
5	7001-046	2	PIN				
6	7001-111	2	PIN				
7	7001-002	1	WLMT LOADER VERTICAL SSL MF				
8	7100-451	1	CYLINDER TILT RH				
9	7000-410	3	HOSE, -8, 4000 PSI, 8FFORX, 8FFORX, 17.8				
10	7000-412	1	HOSE, -8, 4000 PSI, 8FFORX, 8FFORX, 19.3				
11	0310-345	4	ADAPTER,8MFFOR-8MB				
12	0003-053	2	BUSHING ROD END 1.75 x 1.5 x 2.00 AURELIUS # 56107				
13	7000-802	2	BUSHING BASE END				
14	7000-342	2	BUSHING,SPRING, 1 3/4" X 1 1/2" X 3"				
15	2040-115	2	WLMT PIN 6.00"				
16	7001-109	2	PIN				
17	7000-665	2	BUSHING BASE END BOOM CYLINDER				
18	7001-449	2	CYLINDER BOOM				
19	0003-056	2	BUSHING ROD END BOOM CYLINDER				
20	7001-071	2	PIN				
21	8040-366	2	NUT,HEX,NYLOCK,1/4-20 UNC,ZN				
22	8102-050	2	CAPSCREW,HH,1/4-20,UNC,2.75ZN,GD8				
23	7001-053	2	BUSHING				
24	7001-227	2	LINKAGE				
25	7001-054	4	BUSHING				
26	7001-112	2	BUSHING				
27	7001-049	2	PIN				
28	7001-044	2	ASSY CONTROL ARM MF				
29	2055-252	2	SPACER .350" L x 2.0 OD				
30	0090-035	2	RING SNAP INTERNAL 2 3/8"				
31	2055-216	2	BEARING,SPHERICAL,1.75 O.D.				
32	7001-211	2	CAP CONTROL ARM SPACER				
33	8102-239	2	CAPSCREW,HH,				
34	8040-486	2	NUT,HEX,NYLOCK,3/8-16 UNC,ZN				
35	8102-224	4	CAPSCREW,HH,3/8-16UNCx1.25,GD8,ZN				
36	7100-450	1	CYLINDER TILT LH				
37	0200-317	2	PLUG,HOLE,1/4"				
38	0310-345	4	ADAPTER,8MFFOR-8MB				
39	7001-174	3	HOSE -8 4000PSI 8FFORX, 8FFORX45 15"				
40	7001-173	1	HOSE -8 4000PSI 8FFORX, 8FFORX45 13"				

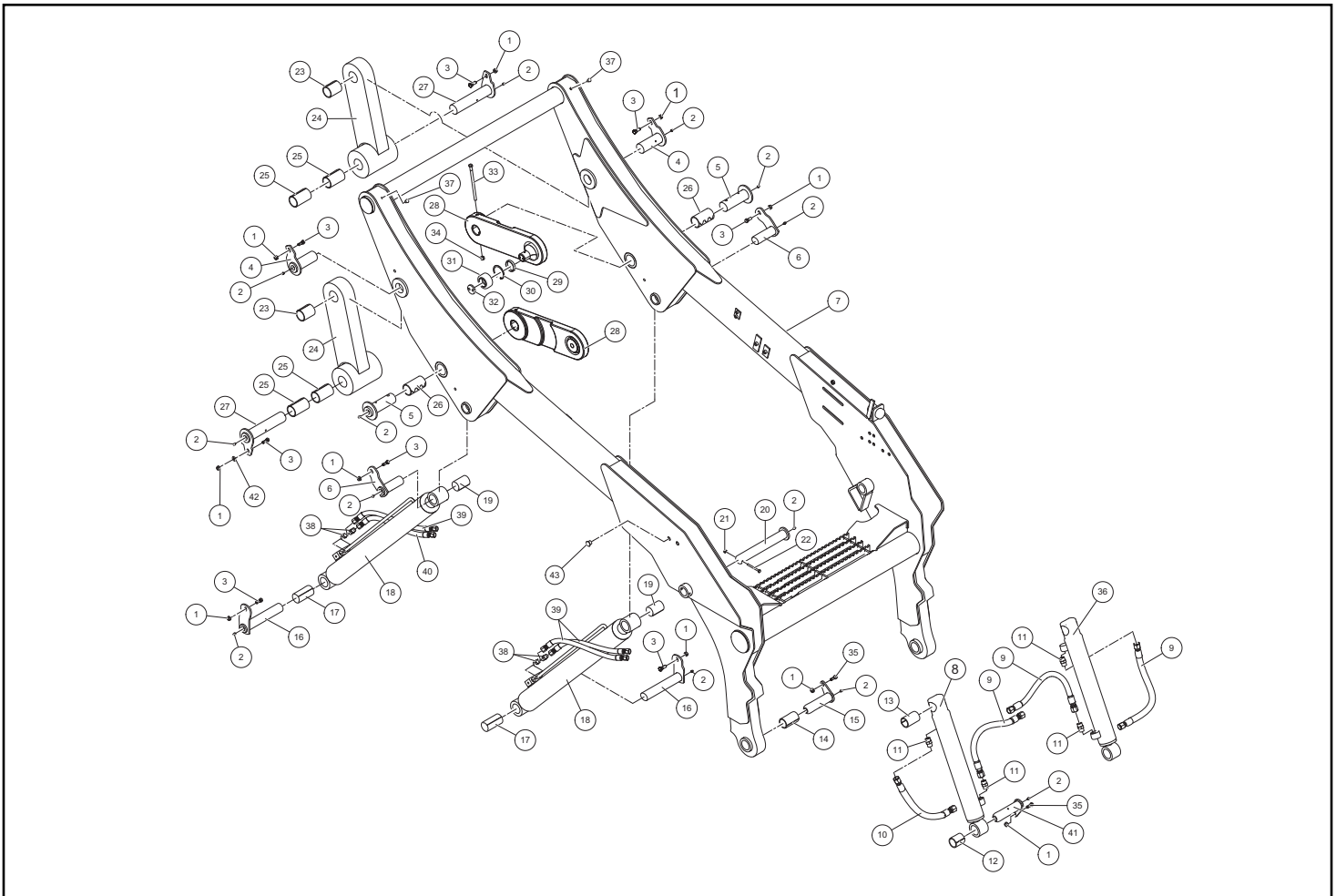

# HYD. CYLINDERS / LIFT ARM ASSEMBLY

VS-60 Serial # 00500-00500  
V230S Serial # 00466-00513

Chapter 3

REF. NO.	PART NUMBER	QTY.	DESCRIPTION	REF. NO.	PART NUMBER	QTY.	DESCRIPTION
1	0314-269	12	NUT,FLANGE,TOPLK,3/8-16UNC,GDG,ZN	41	2040-325	2	WLMT, PIN, QA TILT,6.00
2	0300-607	12	ZERK,GREASE,1/4-28 1103K21	42	0090-527	4	BOLT 3/8" 25/32" O.D. ZINC PUSHNUT
3	8102-222	4	CAPSCREW,HH,3/8-16 UNCx1.0,GD8,ZN	43	0090-562	4	PLUG TREE STYLE 1" HEAD X 0.42 X 1.2
4	7001-052	2	PIN	44	2055-216	2	BEARING,SPHERICAL,1.75 O.D.
5	7001-046	2	PIN	45	8111-224	2	BOLT,CARRIAGE,3/8-16UNCx1.25,GD8
6	7001-111	2	PIN				
7	7001-002	1	WLMT LOADER VERTICAL SSL MF				
8	7100-451	1	CYLINDER TILT RH				
9	7000-410	3	HOSE, -8, 4000 PSI, 8FFORX, 8FFORX, 17.8				
10	7000-412	1	HOSE, -8, 4000 PSI, 8FFORX, 8FFORX, 19.3				
11	0310-345	4	ADAPTER,8MFFOR-8MB				
12	0003-053	2	BUSHING ROD END 1.75 x 1.5 x 2.00 AURELIUS # 56107				
13	7000-802	2	BUSHING BASE END				
14	7000-342	2	BUSHING,SPRING, 1 3/4" X 1 1/2" X 3"				
15	2040-115	2	WLMT PIN 6.00"				
16	7001-109	2	PIN				
17	7000-665	2	BUSHING BASE END BOOM CYLINDER				
18	7001-449	2	CYLINDER BOOM				
19	0003-056	2	BUSHING ROD END BOOM CYLINDER				
20	7001-071	2	PIN				
21	8040-366	2	NUT,HEX,NYLOCK,1/4-20 UNC,ZN				
22	8102-050	2	CAPSCREW,HH,1/4-20,UNC,2.75ZN,GD8				
23	7001-053	2	BUSHING				
24	7001-227	2	LINKAGE				
25	7001-054	4	BUSHING				
26	7001-112	2	BUSHING				
27	7001-049	2	PIN				
28	7001-460	2	ASSY CONTROL ARM MF				
29	2055-252	2	SPACER .350" L x 2.0 OD				
30	0090-035	2	RING SNAP INTERNAL 2 3/8"				
31	7006-518	2	BEARING, SPHERICAL, 1.75"				
32	7001-211	2	CAP CONTROL ARM SPACER				
33	0090-649	2	RING, RETAINING, INTERNAL, 2 13/16"				
34	0090-651	2	RING, RETAINING, EXTERNAL, 1 3/4"				
35	8102-224	4	CAPSCREW,HH,3/8-16UNCx1.25,GD8,ZN				
36	7100-450	1	CYLINDER TILT LH				
37	0200-317	2	PLUG,HOLE,1/4"				
38	0310-345	4	ADAPTER,8MFFOR-8MB				
39	7001-174	3	HOSE -8 4000PSI 8FFORX, 8FFORX45 15"				
40	7001-173	1	HOSE -8 4000PSI 8FFORX, 8FFORX45 13"				

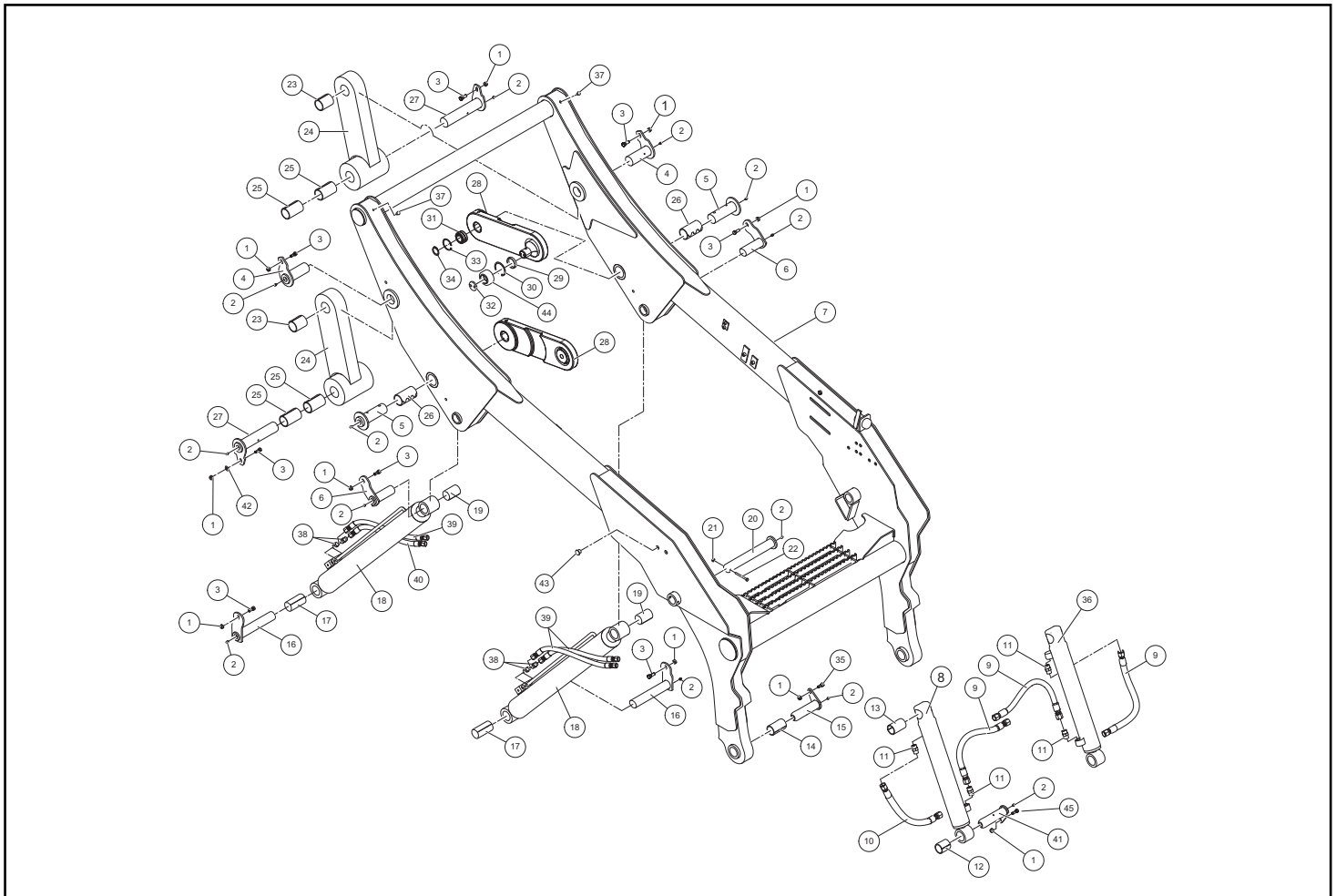

# HYD. CYLINDERS / LIFT ARM ASSEMBLY

VS-60 Serial # Valid from - 00501  
V230S Serial # Valid from - 00514

Chapter 3

REF. NO.	PART NUMBER	QTY.	DESCRIPTION	REF. NO.	PART NUMBER	QTY.	DESCRIPTION
1	0314-269	12	NUT,FLANGE,TOPLK,3/8-16UNC,GDG,ZN	41	2040-325	2	WLMT, PIN, QA TILT,6.00
2	0300-607	12	ZERK,GREASE,1/4-28 1103K21	42	0090-527	4	BOLT 3/8" 25/32" O.D. ZINC PUSHNUT
3	8102-222	4	CAPSCREW,HH,3/8-16 UNCx1.0,GD8,ZN	43	0090-562	4	PLUG TREE STYLE 1" HEAD X 0.42 X 1.2
4	7001-052	2	PIN	44	2055-216	2	BEARING,SPHERICAL,1.75 O.D.
5	7001-046	2	PIN				
6	7001-111	2	PIN				
7	7001-002	1	WLMT LOADER VERTICAL SSL MF				
8	7100-451	1	CYLINDER TILT RH				
9	7000-410	3	HOSE, -8, 4000 PSI, 8FFORX, 8FFORX, 17.8				
10	7000-412	1	HOSE, -8, 4000 PSI, 8FFORX, 8FFORX, 19.3				
11	0310-345	4	ADAPTER,8MFFOR-8MB				
12	0003-053	2	BUSHING ROD END 1.75 x 1.5 x 2.00 AURELIUS # 56107				
13	7000-802	2	BUSHING BASE END				
14	7000-342	2	BUSHING,SPRING, 1 3/4" X 1 1/2" X 3"				
15	2040-115	2	WLMT PIN 6.00"				
16	7001-109	2	PIN				
17	7000-665	2	BUSHING BASE END BOOM CYLINDER				
18	7001-449	2	CYLINDER BOOM				
19	0003-056	2	BUSHING ROD END BOOM CYLINDER				
20	7001-071	2	PIN				
21	8040-366	2	NUT,HEX,NYLOCK,1/4-20 UNC,ZN				
22	8102-050	2	CAPSCREW,HH,1/4-20,UNC,2.75ZN,GD8				
23	7001-053	2	BUSHING				
24	7001-227	2	LINKAGE				
25	7001-054	4	BUSHING				
26	7001-112	2	BUSHING				
27	7001-049	2	PIN				
28	7001-460	2	ASSY CONTROL ARM MF				
29	2055-252	2	SPACER .350" L x 2.0 OD				
30	0090-035	2	RING SNAP INTERNAL 2 3/8"				
31	7006-518	2	BEARING, SPHERICAL, 1.75"				
32	7001-211	2	CAP CONTROL ARM SPACER				
33	0090-649	2	RING, RETAINING, INTERNAL, 2 13/16"				
34	0090-651	2	RING, RETAINING, EXTERNAL, 1 3/4"				
35	8102-224	4	CAPSCREW,HH,3/8-16UNCx1.25,GD8,ZN				
36	7100-450	1	CYLINDER TILT LH				
37	0200-317	2	PLUG,HOLE,1/4"				
38	0315-001	4	ADAPTOR, 8MBOR, WEO FEMALE PLUG IN				
39	7001-467	1	HOSE, -8, 4000 PSI, 0314-532, 8FFORX45, 13.75"				
40	7001-468	3	HOSE, -8, 4000 PSI, 0314-532, 8FFORX45, 15.75"				

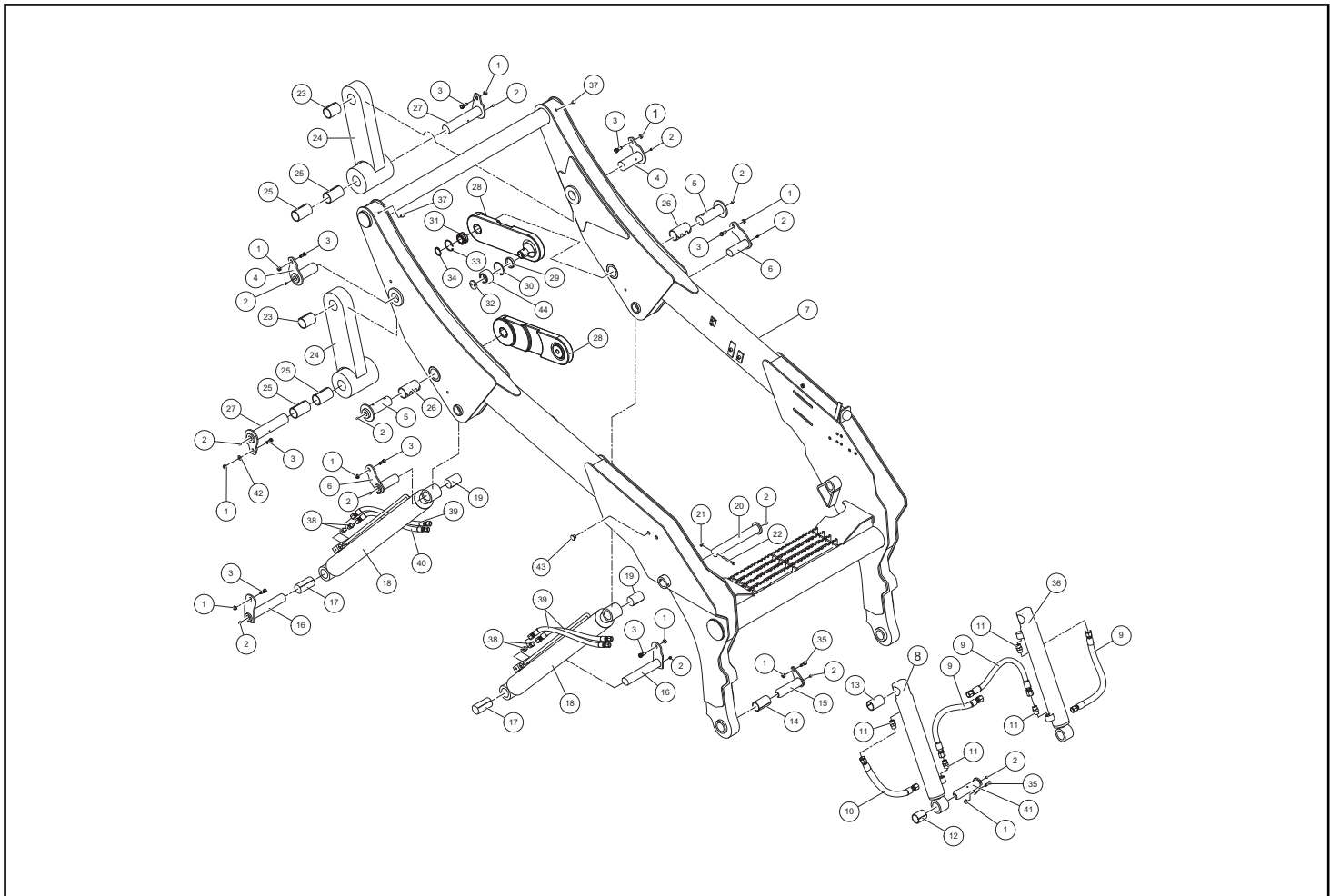

# LIFT ARM TUBES / FITTINGS

VS-60 Serial # Valid from 00500  
V230S Serial # Valid from 00101

Chapter 3

REF. NO.	PART NUMBER	QTY.	DESCRIPTION	REF. NO.	PART NUMBER	QTY.	DESCRIPTION
1	7001-066	1	TUBE				
2	7001-067	1	TUBE				
3	7001-068	1	TUBE BOOM RH 3				
4	7001-069	1	TUBE BOOM RH 4				
5	0201-225	4	CLAMP,SET,T2038-PP				
6	0310-584	9	PLATE,COVER TCP-T2 TCP-T2				
7	8102-044	4	CAPSCREW,HH,1/4-20UNCx1.25,GD8,ZN				
8	0310-831	5	CLAMP, SET, T2062-PP BEHRINGER				
9	8102-134	7	CAPSCREW,HH,5/16-18UNCx1.25GD8 ZN				
10	7001-121	1	HOSE, -8, 4000PSI, 6FFORX, 54				
11	7001-120	1	HOSE, -8, 4000PSI, 8FFORS, 8FFORS, 53"				
12	7001-124	2	HOSE				
13	7001-122	1	HOSE				
14	0300-582	3	CABLE,TIE,SMALL #9629				
15	0310-567	1	ADAPTER,8MFFOR-6MB				
16	0201-658	2	ADAPTER,10MFFOR-8MB-SV				
17	7001-065	1	TUBE				
18	7001-064	1	TUBE				
19	7001-063	1	TUBE				
20	0201-402	1	CLAMP,SET,2050-PP				
21	0201-838	1	SPOOL,VALVE,QD BLOCK				
22	8102-050	4	CAPSCREW,HH,1/4-20,UNC,2.75ZN,GD8				
23	0304-188	1	PLUG,6 ORING				
24	0304-876	1	MANIFOLD,AUX,HYD INNOTEK 22255 QD				
25	0200-296	2	ADAPTER,O-RING HEX NIPPLE,10-8				
26	0310-077	1	COUPLER,QUICK,FF,MALE,				
27	0310-076	1	COUPLER,QUICK,FF,				
28	0201-224	1	COVER,CLAMP,COP-2				

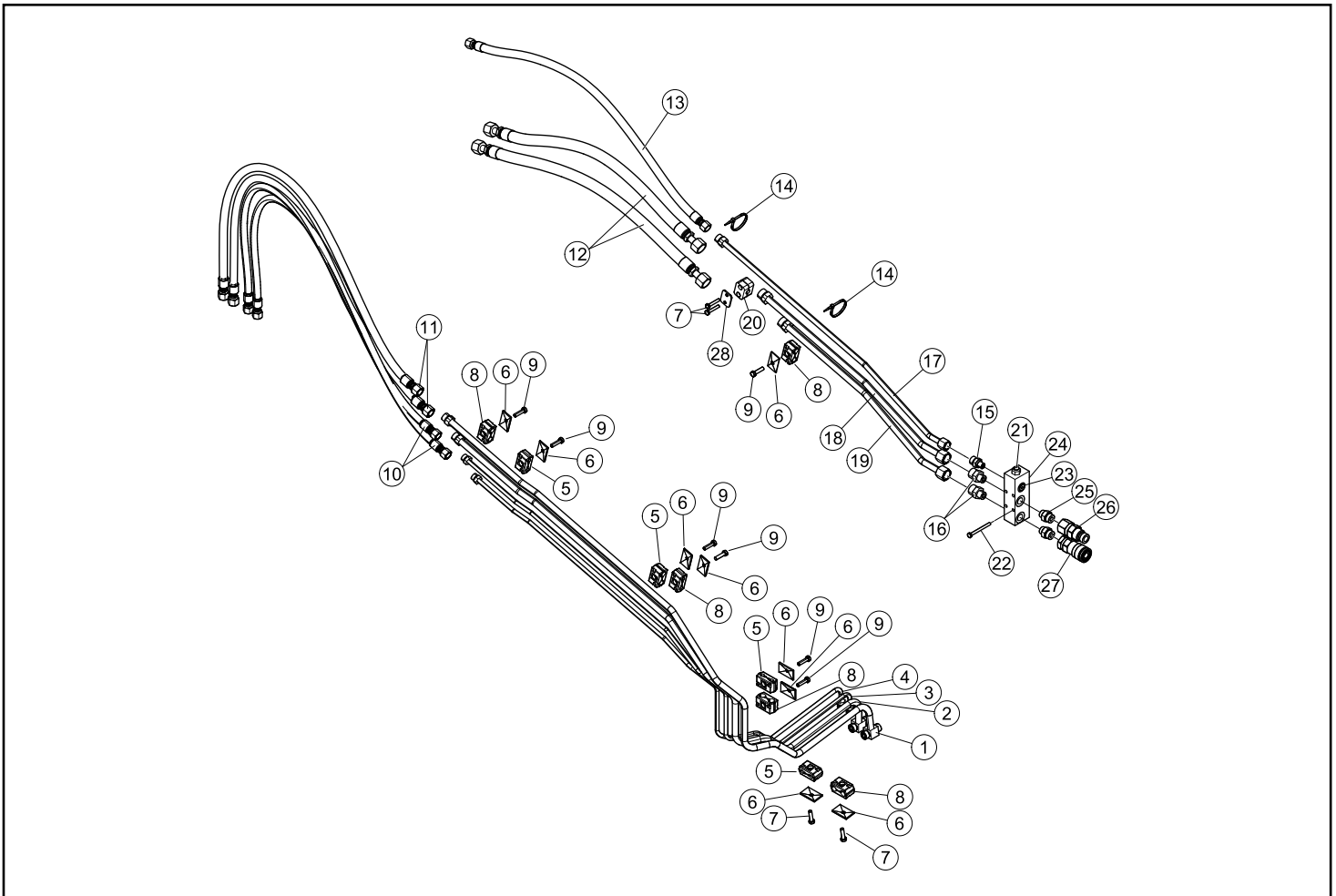

# HYDRAULIC CONTROL - SINGLE SPEED

VS-60 Serial # Valid from 00500  
V230S Serial # Valid from 00101

REF. NO.	PART NUMBER	QTY.	DESCRIPTION
1	7000-335	2	TUBE DRIVE 1 SPEED BTM RH MF
2	0315-013	4	ADAPTER,12MFFOR-10MB
3	7000-314	2	TUBE DRIVE TOP 1 SPEED RH MF
4	7000-370	2	HOSE, -12, 6000 PSI, 12FFORX, 12FFORX,17
5	7001-485	2	MOTOR SINGLE SPEED MCR3, SERIES 33, 400cc
6	0201-309	2	ADAPTER,FS6400-04-06-0
7	7000-312	1	TUBE BRAKE 1 SPEED RH MF
8	7000-313	1	TUBE BRAKE 1 SPEED LH MF
9	7000-289	1	TUBE 1 HYD QUICK
10	7000-299	1	HYDRAULIC QUICK TUBE 3
11	2075-359	1	VALVE 2 POS 4 WAY SV08
12	0310-329	10	ADAPTER,6MFFOR-6MB
13	8102-045	2	CAPSCREW,HH,1/4-20x1.5"ZN GD8
14	8051-212	2	WASHER,SPRING LOCK,1/4,ZN
15	7000-324	1	HYDRAULIC QUICK TUBE 3
16	7000-290	1	HYDRAULIC QUICK TUBE 2
17	7000-121	1	ASSY TUBE HYD LOADER A MF
18	7000-127	1	TUBE CROSS LOADER VALVE HYD MF
19	7000-120	1	ASSY TUBE HYD LOADER B
20	7000-300	1	TUBE 1 BOOM EMERGENCY
21	7000-288	1	TUBE, LOADER, BOOM CYL, LH
22	7000-122	1	ASSY TUBE HYD CURL B MF
23	7000-123	1	ASSY TUBE HYD CURL A MF
24	7000-315	1	TUBE HYD AUX B
25	7000-316	1	TUBE HYD AUX A
26	7000-332	1	TUBE, HIGH FLOW FEED
27	7000-338	1	TUBE, VALVE, MAIN FEED
28	7000-982	1	J2 MF GEN BLOCK TUBE
29	7000-297	1	TUBE, J2 TO VALVE PRESSURE
30	7000-305	1	TUBE 1 VALVE PRESSURE
31	7000-480	1	HOSE, -6, 3000 PSI, 6FFORX, 6FFORX, 73.4"
32	7000-307	1	TUBE GEN BLOCK TO TANK #6
33	7000-304	1	TUBE 2 VALVE TO TANK
34	7000-303	1	TUBE 1 VALVE TO TANK
35	7000-292	1	TUBE VALVE TO FILTER
36	0404-161	1	FILTER SPIN-ON HYD
37	0201-403	1	HEAD,FILTER
38	8102-222	4	CAPSCREW,HH,3/8-16 UNCx1.0,GD8,ZN
39	8051-272	4	WASHER,SPRING LOCK,3/8,ZN
40	7000-277	1	VALVE BYPASS 80 PSI

REF. NO.	PART NUMBER	QTY.	DESCRIPTION
41	0310-312	1	ADAPTER,16MFFOR-16MB
42	8102-048	2	CAPSCREW,HH,1/4-20UNCx2.25,GD8
43	8050-222	2	WASHER,WROUGHT,1/4,STD,ZN
44	8102-134	9	CAPSCREW,HH,5/16-18UNCx1.25GD8 ZN
45	0310-584	9	PLATE,COVER TCP-T2 TCP-T2
46	0201-225	3	CLAMP,SET,T2038-PP
47	0310-831	7	CLAMP, SET, T2062-PP BEHRINGER
48	0201-227	2	CLAMP,COVER,TCP-T4
49	0201-226	2	CLAMP,SET,T4100-PP
50	8102-044	10	CAPSCREW,HH,1/4-20UNCx1.25,GD8,ZN
51	0201-224	1	COVER,CLAMP,COP-2
52	0201-402	1	CLAMP,SET,2050-PP
53	2045-581	3	PLATE COVER COP-1
54	2045-580	3	CLAMP SET 1038-PP
55	7000-369	2	HOSE, -12, 6000 PSI, 12FFORX, 12FFORX, 2
56	7000-319	1	TUBE 1 SPEED CASE DRAIN LH #6
57	7000-318	1	TUBE 1 SPEED CASE DRAIN RH #6
58	7000-531	1	TUBE JOYSTICK BUCKET DUMP
59	7000-530	1	TUBE JOYSTICK BOOM DOWN
60	8102-137	2	CAPSCREW,HH,5/16-18UNCx2.0 GD8 ZN
61	0310-343	1	ADAPTER,16MFFOR-16MB-90^
62	0310-339	1	ADAPTER,CAP
63	0310-466	1	CLAMP,WIRE,3/4 RBC-3/4
64	8102-135	2	CAPSCREW,HH,5/16-18X1.50ZN,GD8
65	0118-168	1	SPOOL,SOLENOID,2POSITION,4WAY
66	0200-364	1	SOLENOID
67	8040-426	1	NUT,HEX,NYLOCK,5/16-18 UNC
68	8050-262	2	WASHER,WROUGHT,5/16,STD,ZN
69	7000-808	1	SPRING 2.75"
70	2051-981	1	CLAMP P 2-3/4" I.D

For kit information, please see page 10-1A

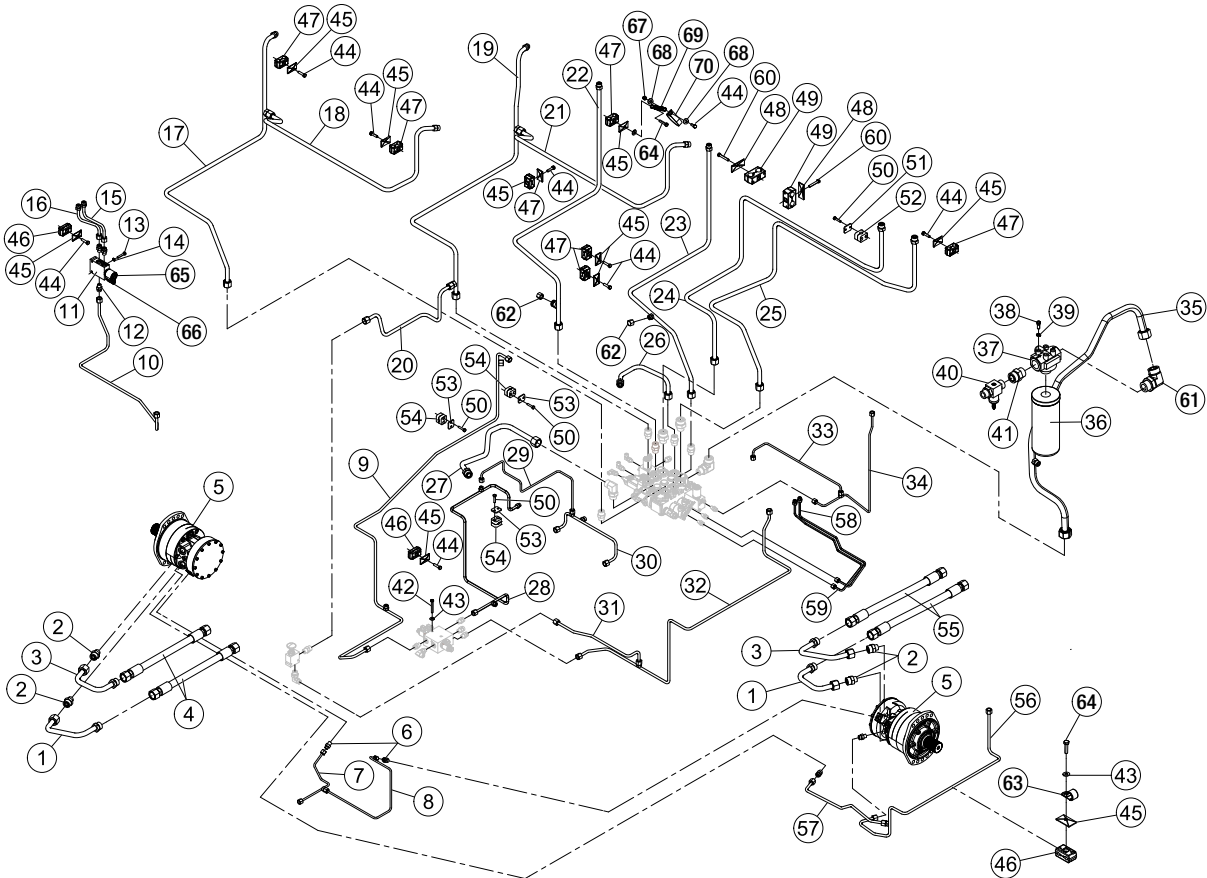

# HYDRAULIC CONTROL - TWO SPEED

VS-60 Serial # Valid from 00500  
V230S Serial # Valid from 00101

REF. NO.	PART NUMBER	QTY.	DESCRIPTION
1	7000-365	1	TUBE, 2 SPEED, RH 2 SPEED
2	7000-366	1	TUBE, 2 SPEED, LH 2 SPEED
3	0201-654	2	ADAPTER,FS,6400,04,06,SHORT
4	7000-361	2	TUBE, 2 SPEED, RH BRAKE
5	0315-005	4	ADAPTER,12MFFOR-12MB
6	0201-309	4	ADAPTER,FS6400-04-06-0
7	8102-406	20	CAPSCREW,HH,1/2-13UNCx1.75,GD8
8	8040-606	20	NUT,HEX,NYLOCK,1/2-13 UNC,ZN
9	0310-345	13	ADAPTER,8MFFOR-8MB
10	7000-300	1	TUBE 1 BOOM EMERGENCY
11	7001-084	1	TUBE
12	7000-289	1	TUBE 1 HYD QUICK
13	8102-134	9	CAPSCREW,HH,5/16-18UNCx1.25GD8 ZN
14	0310-584	9	PLATE,COVER TCP-T2 TCP-T2
15	0201-225	3	CLAMP,SET,T2038-PP
16	0310-831	6	CLAMP, SET, T2062-PP BEHRINGER
17	2045-580	5	CLAMP SET 1038-PP
18	2045-581	5	PLATE COVER COP-1
19	8102-044	12	CAPSCREW,HH,1/4-20UNCx1.25,GD8,ZN
20	7000-122	1	ASSY TUBE HYD CURL B MF
21	7000-290	1	HYDRAULIC QUICK TUBE 2
22	7000-324	1	HYDRAULIC QUICK TUBE 3
23	0310-329	8	ADAPTER,6MFFOR-6MB
24	2075-359	1	VALVE 2 POS 4 WAY SV08
25	7000-299	1	HYDRAULIC QUICK TUBE 3
26	7001-083	1	TUBE
27	7001-183	1	TUBE A LOADER DWN
28	7000-123	1	ASSY TUBE HYD CURL A MF
29	7000-316	1	TUBE HYD AUX A
30	7000-315	1	TUBE HYD AUX B
31	7001-085	1	TUBE
32	0201-226	3	CLAMP,SET,T4100-PP
33	0201-227	3	CLAMP,COVER,TCP-T4
34	8102-137	3	CAPSCREW,HH,5/16-18UNCx2.0 GD8 ZN
35	0310-312	1	ADAPTER,16MFFOR-16MB
36	7000-274	1	TEE RETURN VALVE
37	8102-222	12	CAPSCREW,HH,3/8-16 UNCx1.0,GD8,ZN
38	8051-272	8	WASHER,SPRING LOCK,3/8,ZN
39	0201-402	1	CLAMP,SET,2050-PP
40	0201-224	1	COVER,CLAMP,COP-2

REF. NO.	PART NUMBER	QTY.	DESCRIPTION
41	7000-291	1	BOOM CASE DRAIN TUBE
42	0404-161	1	FILTER SPIN-ON HYD
43	0201-403	1	HEAD,FILTER
44	7000-292	1	TUBE VALVE TO FILTER
45	7000-303	1	TUBE 1 VALVE TO TANK
46	7000-304	1	TUBE 2 VALVE TO TANK
47	7000-305	1	TUBE 1 VALVE PRESSURE
48	7000-297	1	TUBE, J2 TO VALVE PRESSURE
49	7000-982	1	J2 MF GEN BLOCK TUBE
50	0310-321	1	ADAPTER,12MFFOR-12MB90
51	7000-338	1	TUBE, VALVE, MAIN FEED
52	7000-364	1	TUBE, 2 SPEED, LH CASEDRAIN
53	7000-365	1	TUBE, 2 SPEED, RH 2 SPEED
54	7000-363	1	TUBE, 2 SPEED, RH CASEDRAIN
55	7000-480	1	HOSE, -6, 3000 PSI, 6FFORX, 6FFORX, 73.4"
56	7000-308	1	2 SPEED TANK DUMP TUBE
57	8102-045	2	CAPSCREW,HH,1/4-20x1.5"ZN GD8
58	8051-212	2	WASHER,SPRING LOCK,1/4,ZN
59	7000-983	1	MF 2 SPEED PRESSURE TUBE
60	7001-487	1	MOTOR TWO SPEED, MCR3, SERIES 33, 400cc
61	7000-367	2	HOSE, -12, 6000 PSI, 12FFORX, 12FFORX, "
62	7000-368	2	HOSE, -12, 6000 PSI, 12FFORX, 12FFORX, "
63	7000-358	1	TUBE, 2 SPEED, RH DRIVE BOTTOM
64	7000-357	1	TUBE, 2 SPEED, RH DRIVE TOP
65	7000-531	1	TUBE JOYSTICK BUCKET DUMP
66	7000-530	1	TUBE JOYSTICK BOOM DOWN
67	0310-343	1	ADAPTER,16MFFOR-16MB-90^
68	7001-184	1	TUBE B LOADER DWN
69	0118-168	1	SPOOL,SOLENOID,2POSITION,4WAY
70	0200-364	1	SOLENOID
71	7001-487	2	MOTOR TWO SPEED, MCR3, SERIES 33, 400cc
72	8050-262	3	WASHER,WROUGHT,5/16,STD,ZN
73	8040-426	1	NUT,HEX,NYLOCK,5/16-18 UNC
74	7000-808	1	SPRING 2.75"
75	2051-981	1	CLAMP P 2-3/4" I.D

For kit information, please see page 10-1A

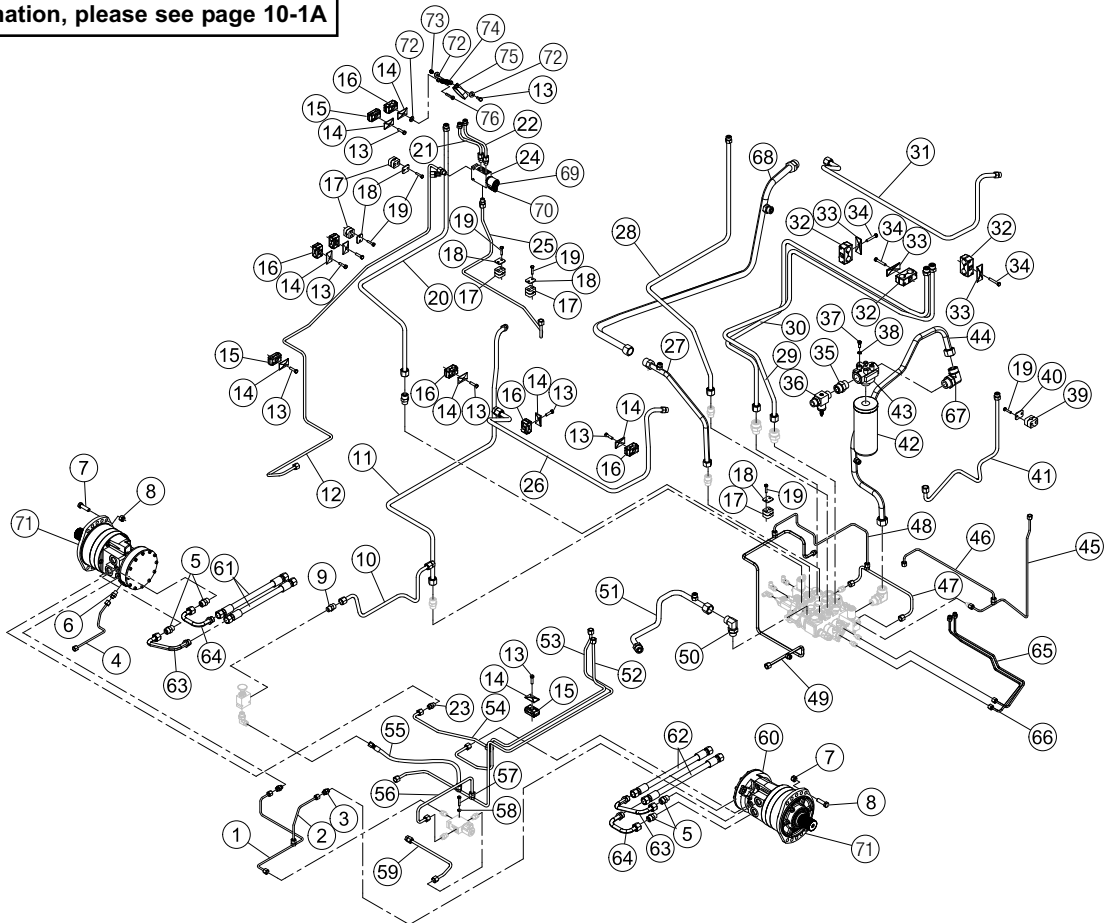

# HYDRAULIC DRIVE / AUXILIARY

VS-60 Serial # 00500-00510  
V230S Serial # 00101-00511

Chapter 3

REF. NO.	PART NUMBER	QTY.	DESCRIPTION
1	7000-118	1	TUBE,INTAKE
2	0303-238	2	CLAMP,HOSE,
3	0304-528	1	HOSE,RES,1.5x9
4	2010-730	1	HOSE 1.575" PARKER EZ SERIES
5	0310-468	8	CAPSCREW,HH,M10x1.5x35,ZINC
6	0301-781	8	WASHER,SPLIT LOCK,10mm,ZN
7	0200-171	2	COUPLING,SPLIT,CODE 61,1.25"
8	0310-294	1	O-RING,#222,1.50x1.75x.13 ( LUTZ )
9	7001-414	1	PUMP,HYD,AUX
10	7000-744	1	ADAPTER,10MFFOR-10MB45
11	0200-172	2	COUPLING,SPLIT,CODE 61,0.75"
12	0200-337	2	CAPSCREW,HH,M12x1.75x40MM,GR8.8
13	8051-272	2	WASHER,SPRING LOCK,3/8,ZN
14	-----	1	SEE LIST IN ILLUSTRATION
15	0310-329	2	ADAPTER,6MFFOR-6MB
16	0201-314	2	ADAPTER,FS6801-04-04-NW0
17	0201-575	2	CAPSCREW,HH,1/2-13x1.625,GD8
18	0090-148	2	WASHER SPRING LOCK 1/2 ZN
19	0304-404	2	WASHER,FLAT,1.125 OD x .5 ID x 1/4,ZN
20	0200-104	1	HUB,PUMP DRIVE,1 1/4" x 14
21	7000-496	1	HOSE -16 400PSI 10FFORX 10FFORX 22.6"
22	7000-562	1	HOSE -6 3000PSI 6FFORX 6FFORX90S 39.32"
23	7000-964	1	TUBE CHARGE -10
24	0310-557	2	ADAPTER,6MFFOR-4MB-90
25	0310-332	1	ADAPTER,10MFFOR-12MB
26	0201-658	1	ADAPTER,10MFFOR-8MB-SV
27	0201-316	2	ADAPTER,FS6801-L-12-12-NW0
28	0310-321	2	ADAPTER,12MFFOR-12MB90
29	7000-739	1	HOSE, -12, 4000 PSI, 16FL, 12FFORX45, 25"
30	-----	1	SEE LIST IN ILLUSTRATION
31	7000-441	1	JOYSTICK CONTROL LH
32	7000-473	1	HOSE -6 3000 PSI 4FFFORX 6FFORX 135"
33	7000-472	1	HOSE -6 3000 PSI 4FFFORX 4FFORX 100"
34	7000-479	2	HOSE PILOT
35	7000-476	1	HOSE -6 3000 PSI 4FFFORX 6 FFORX 114"
36	7000-475	2	HOSE -6 3000 PSI 4FFFORX 4FFORX 115"
37	7000-477	2	HOSE PILOT
38	7000-474	1	HOSE -6 3000 PSI 4FFORX 6FFORX 95"
39	7000-480	1	HOSE -4 3000PSI 4FFFORX 4FFORX 56.8"
40	7000-478	1	HOSE -6 3000PSI 6FFFORX 6FFORX 95"

REF. NO.	PART NUMBER	QTY.	DESCRIPTION
41	7000-528	1	TUBE JOYSTICK PRESSURE DRIVE
42	0304-516	1	HMAGNET,DETENT
43	8102-040	8	CAPSCREW,HH,1/4-20 UNCx.75,GD8 ZN
44	8040-366	8	NUT,HEX,NYLOCK,1/4-20 UNC,ZN
45	2010-138	1	KIT CARDAN RH
46	0307-882	2	TIE,CABLE,BLACK,18.1",W/STL INSERT
47	2045-735	2	BOOT CONTROLLER
48	0304-441	1	SWITCH,PRESSURE
49	0403-001	4	O-RING VALVE RELIEF
50	0403-002	4	O-RING BACK-UP VALVE RELIEF
51	0201-876	4	VALVE,RELIEF,5500 PSI
52	0307-169	1	O-RING,4.0" ID x 4-3/16" OD BUNA 2-155
53	7000-884	1	HOSE -12,3300PSI 12FFORX 12FFORX 15.5"

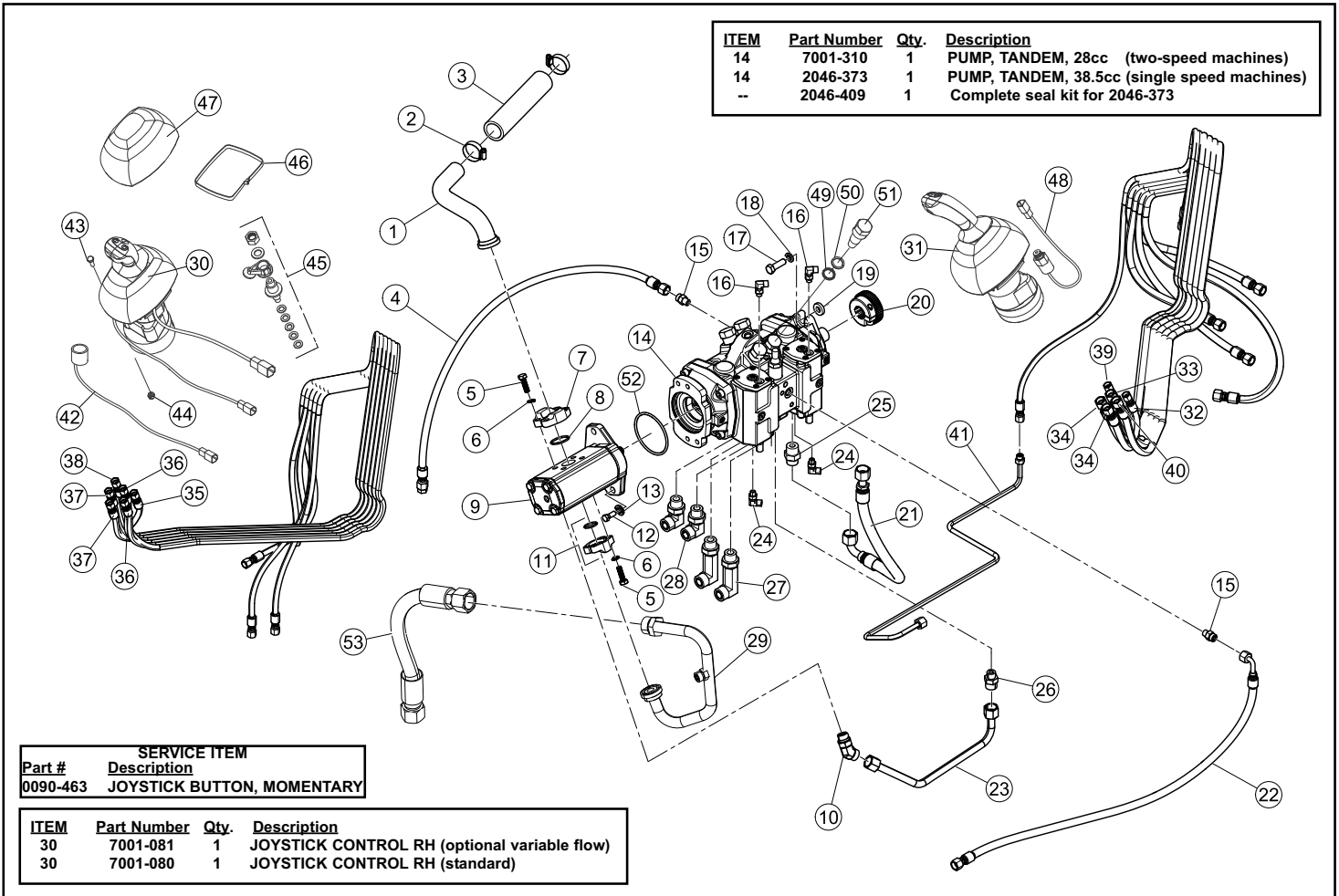

ITEM	Part Number	Qty.	Description
14	7001-310	1	PUMP, TANDEM, 28cc (two-speed machines)
14	2046-373	1	PUMP, TANDEM, 38.5cc (single speed machines)
--	2046-409	1	Complete seal kit for 2046-373

SERVICE ITEM	
Part #	Description
0090-463	JOYSTICK BUTTON, MOMENTARY

ITEM	Part Number	Qty.	Description
30	7001-081	1	JOYSTICK CONTROL RH (optional variable flow)
30	7001-080	1	JOYSTICK CONTROL RH (standard)

# HYDRAULIC DRIVE / AUXILIARY

VS-60 Serial # valid from 00511  
V230S Serial # valid from 00512

REF. NO.	PART NUMBER	QTY.	DESCRIPTION
1	7000-118	1	TUBE,INTAKE
2	0303-238	2	CLAMP,HOSE,
3	0304-528	1	HOSE,RES,1.5x9
4	2010-730	1	HOSE 1.575" PARKER EZ SERIES
5	0310-468	8	CAPSCREW,HH,M10x1.5x35,ZINC
6	0301-781	8	WASHER,SPLIT LOCK,10mm,ZN
7	0200-171	2	COUPLING,SPLIT,CODE 61,1.25"
8	0310-294	1	O-RING,#222,1.50x1.75x.13 ( LUTZ )
9	7001-414	1	PUMP,HYD,AUX
10	7000-744	1	ADAPTER 10MFFOR-10MB45
11	0200-172	2	COUPLING,SPLIT,CODE 61,0.75"
12	0200-337	2	CAPSCREW,HH,M12x1.75x40MM,GR8.8
13	8051-272	2	WASHER,SPRING LOCK,3/8,ZN
14	-----	1	SEE LIST IN ILLUSTRATION
15	0310-329	2	ADAPTER,6MFFOR-6MB
16	0201-314	2	ADAPTER,FS6801-04-04-NW0
17	0201-575	2	CAPSCREW,HH,1/2-13x1.625,GD8
18	0090-148	2	WASHER SPRING LOCK 1/2 ZN
19	0304-404	2	WASHER,FLAT,1.125 OD x .5 ID x 1/4,ZN
20	0200-104	1	HUB,PUMP DRIVE,1 1/4" x 14
21	7000-496	1	HOSE -16 400PSI 10FFORX 10FFORX 22.6"
22	7000-562	1	HOSE -6 3000PSI 6FFORX 6FFORX90S 39.32"
23	7000-964	1	TUBE CHARGE -10
24	0310-557	2	ADAPTER,6MFFOR-4MB-90
25	0310-332	1	ADAPTER,10MFFOR-12MB
26	0201-658	1	ADAPTER,10MFFOR-8MB-SV
27	0201-316	2	ADAPTER,FS6801-L-12-12-NW0
28	0310-321	2	ADAPTER,12MFFOR-12MB90
29	7000-739	1	HOSE, -12, 4000 PSI, 16FL, 12FFORX45, 25"
30	-----	1	SEE LIST IN ILLUSTRATION
31	7000-441	1	JOYSTICK CONTROL LH
32	7000-473	1	HOSE -6 3000 PSI 4FFFORX 6FFORX 135"
33	7000-472	1	HOSE -6 3000 PSI 4FFFORX 4FFORX 100"
34	7000-479	2	HOSE PILOT
35	7000-476	1	HOSE -6 3000 PSI 4FFFORX 6 FFORX 114"
36	7000-475	2	HOSE -6 3000 PSI 4FFFORX 4FFORX 115"
37	7000-477	2	HOSE PILOT
38	7000-474	1	HOSE -6 3000 PSI 4FFORX 6FFORX 95"
39	7000-480	1	HOSE -4 3000PSI 4FFFORX 4FFORX 56.8"
40	7000-478	1	HOSE -6 3000PSI 6FFORX 6FFORX 95"

REF. NO.	PART NUMBER	QTY.	DESCRIPTION
41	7000-528	1	TUBE JOYSTICK PRESSURE DRIVE
42	0304-516	1	HMAGNET,DETENT
43	8102-040	8	CAPSCREW,HH,1/4-20 UNCx.75,GD8 ZN
44	8040-366	8	NUT,HEX,NYLOCK,1/4-20 UNC,ZN
45	2010-138	1	KIT CARDAN RH
46	0307-882	2	TIE,CABLE,BLACK,18.1",W/STL INSERT
47	2045-735	2	BOOT CONTROLLER
48	0304-441	1	SWITCH,PRESSURE
49	0403-001	4	O-RING VALVE RELIEF
50	0403-002	4	O-RING BACK-UP VALVE RELIEF
51	0201-876	4	VALVE,RELIEF,5500 PSI
52	0307-169	1	O-RING,4.0" ID x 4-3/16" OD BUNA 2-155
53	7000-884	1	HOSE -12,3300PSI 12FFORX 12FFORX 15.5"
54	8050-222	1	WASHER,WROUGHT,1/4,STD,ZN
55	7001-891	1	WLMNT, TUBE, MOUNT BRACKET
56	0201-225	1	CLAMP,SET,T2038-PP
57	7001-887	1	TUBE, PUMP TO PILOT LINE F
58	7001-886	1	TUBE, PUMP TO PILOT LINE E
59	8102-044	1	CAPSCREW,HH,1/4-20UNCx1.25,GD8,ZN

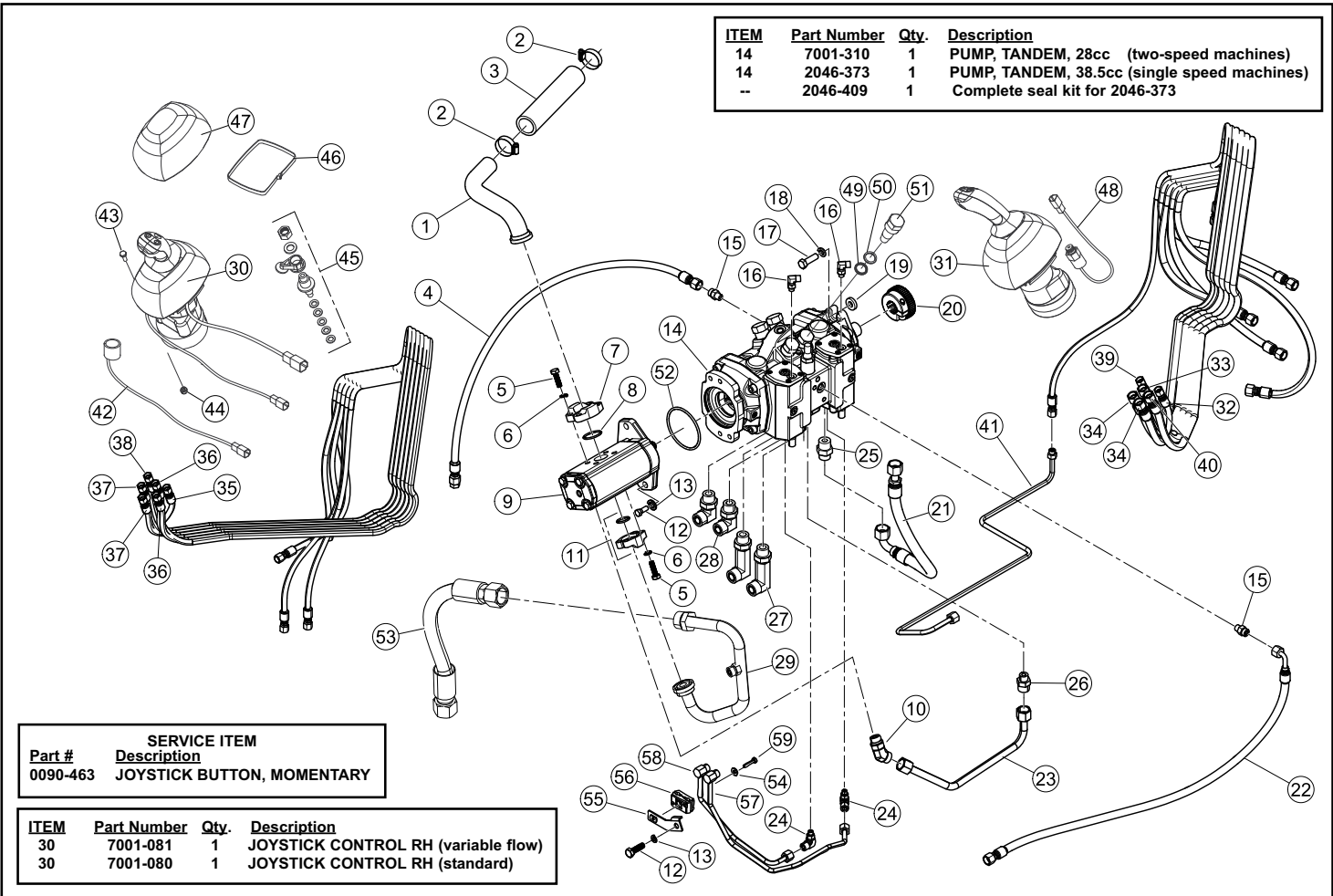

ITEM	Part Number	Qty.	Description
14	7001-310	1	PUMP, TANDEM, 28cc (two-speed machines)
14	2046-373	1	PUMP, TANDEM, 38.5cc (single speed machines)
--	2046-409	1	Complete seal kit for 2046-373

Part #	DESCRIPTION
0090-463	JOYSTICK BUTTON, MOMENTARY

ITEM	Part Number	Qty.	Description
30	7001-081	1	JOYSTICK CONTROL RH (variable flow)
30	7001-080	1	JOYSTICK CONTROL RH (standard)

# Chapter 4

## Electrical

### **4-1 Fuse Panel**

VS-60 Serial # valid from - 00500 **4-1A**

V230S Serial # valid from - 00101 **4-1A**

**\* Parts manuals are updated on a regular basis. Always refer to current online posted manuals to ensure you have the most up to date information prior to ordering parts.**

**NOTE:** Ordering parts that are painted requires a specific part number format. Please refer to page II of this manual for paint code and ordering information

# FUSE PANEL ASSEMBLY

VS-60 Serial # Valid from 00500  
V230S Serial # Valid from 00101

Chapter 4

REF. NO.	PART NUMBER	QTY.	DESCRIPTION	REF. NO.	PART NUMBER	QTY.	DESCRIPTION
1	0304-519	5	RELAY,PLUG,GLOW				
2	2095-910	5	RELAY SONG CHUAN, 301-1C-C-R1				
3	0310-805	1	FUSE,MAXI,80 AMP 7460K51 - 80 AMP				
4	0310-804	1	FUSE,MAXI,60 AMP 78505				
5	0310-801	2	FUSE,MAXI,30 AMP 78502				
6	0310-800	3	FUSE,MAXI,20 AMP 78501				
7	0310-803	1	FUSE,MAXI,50 AMP 78504				
8	0310-802	2	FUSE,MAXI,40 AMP 78503				
9	0310-793	1	FUSE,MINI,2 AMP 77015				
10	0310-796	1	FUSE,MINI,15 AMP 77155				
11	0310-795	5	FUSE,MINI,10 AMP 77105				
12	0310-794	5	FUSE,MINI, 5 AMP 77055				
13	0310-811	1	DIODE, 3 AMP				
14	0310-798	1	FUSE,MINI,25 AMP 77255				
15	0310-779	1	PLUG,DTHD,1PIN DTHD-06-1-8-S				
16	7005-969	1	*HARNES MAIN				
17	0090-239	2	KNOB 1/5-4-20 UNC 2B				
18	2075-810	1	COVER FUSE PANEL				
19	0310-797	1	FUSE,MINI,20 AMP 77205				

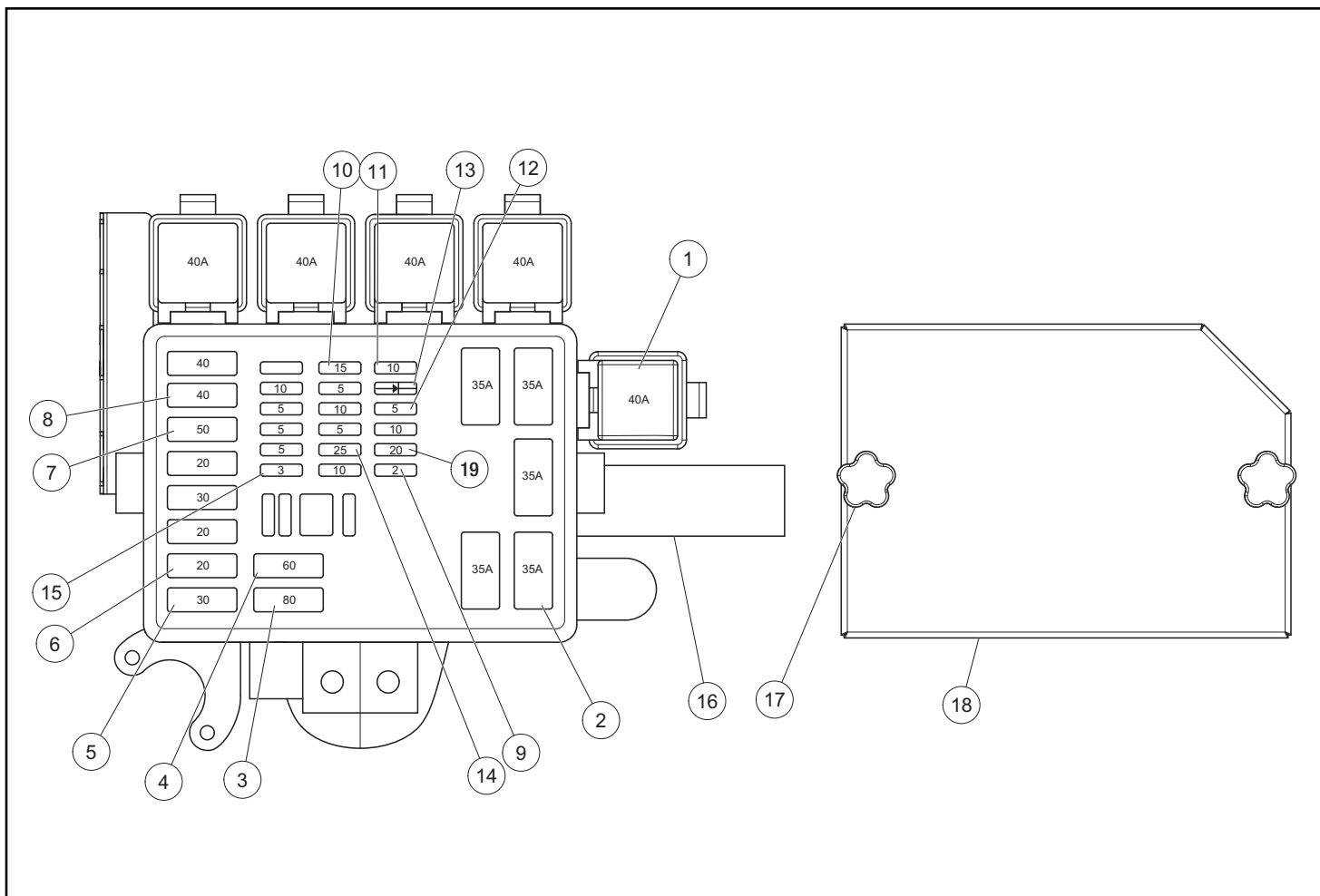

# Chapter 5

## Undercarriage

### **5-1 Final Drive Assembly RT**

VS-60 Serial # valid from - 00500 **5-1A**

V230S Serial # valid from - 00101 **5-1A**

### **5-2 Final Drive Assembly LT**

VS-60 Serial # valid from - 00500 **5-2A**

V230S Serial # valid from - 00101 **5-2A**

**\* Parts manuals are updated on a regular basis. Always refer to current online posted manuals to ensure you have the most up to date information prior to ordering parts.**

**NOTE:** Ordering parts that are painted requires a specific part number format. Please refer to page II of this manual for paint code and ordering information.

# FINAL DRIVE ASSEMBLY, RT

VS-60 Serial # Valid from 00500  
V230S Serial # Valid from 00101

Chapter 5

REF. NO.	PART NUMBER	QTY.	DESCRIPTION	REF. NO.	PART NUMBER	QTY.	DESCRIPTION
1	7000-215	2	CHAIN # 80				
2	7000-217	2	WLMT SPROCKET DRIVEN 80 CHAIN				
3	7000-069	2	SLEEVE HUB MID				
4	7005-062	2	O-RING 2-366 N-70				
5	7005-061	2	O-RING 2-139 N70				
6	7005-060	2	SEAL LIP 70x100x10				
7	7005-057	4	BEARING CONE 389				
8	7005-055	4	BEARING CUP 382A				
9	7000-260	2	HOUSING MACHINED MID				
10	7005-058	2	SEAL FLOATING				
11	7000-067	2	AXLE MACHINED MID				
12	7000-989	2	RIM 16.5x8.25				
13	7000-913	2	TIRE 10.00-16.5 R4 10 Ply SKS				
14	7000-216	2	WLMT SPROCKET DRIVE # 80				
15	0200-337	1	CAPSCREW,HH,M12x1.75x40MM,GR8.8				
16	0090-302	16	Washer, M14 DIN6916 Structural				
17	0090-303	16	NUT,HEX,9/16-18 UNF,ZN				
18	8050-282	1	WASHER,WROUGHT,3/8,STD,ZN				
19	0090-458	32	STUD WHEEL				
20	PH0181-2BP	32	NUT - 9/16-18NF, 90 DEG.TAPER, GR.5				
21	SEE LIST	2	WHEEL/TIRE ASSEMBLY				
22	7000-065	2	ASSEMBLY POD MID SIZE (INCLUDES LUG NUTS, ITEM 20)				
23	7000-059	2	WASHER 1.060" x 2.5 x .25				
24	0090-254	2	WCAPSCREW HH M16-2 x 55MM 10.9				
25	7005-056	2	BEARING CONE 387A				

### ITEM 21

7000-979: Tire & Rim Assembly  
Includes items 12&13

**Note:** Wheel/tire assemblies (21) configured for right side installation are not interchangeable with assemblies for left side installation.

Tires (13) are directional and spacing is different on the inside and outside of the wheels (2).

**Order from this page when replacing tire/wheel assemblies for right side only.**

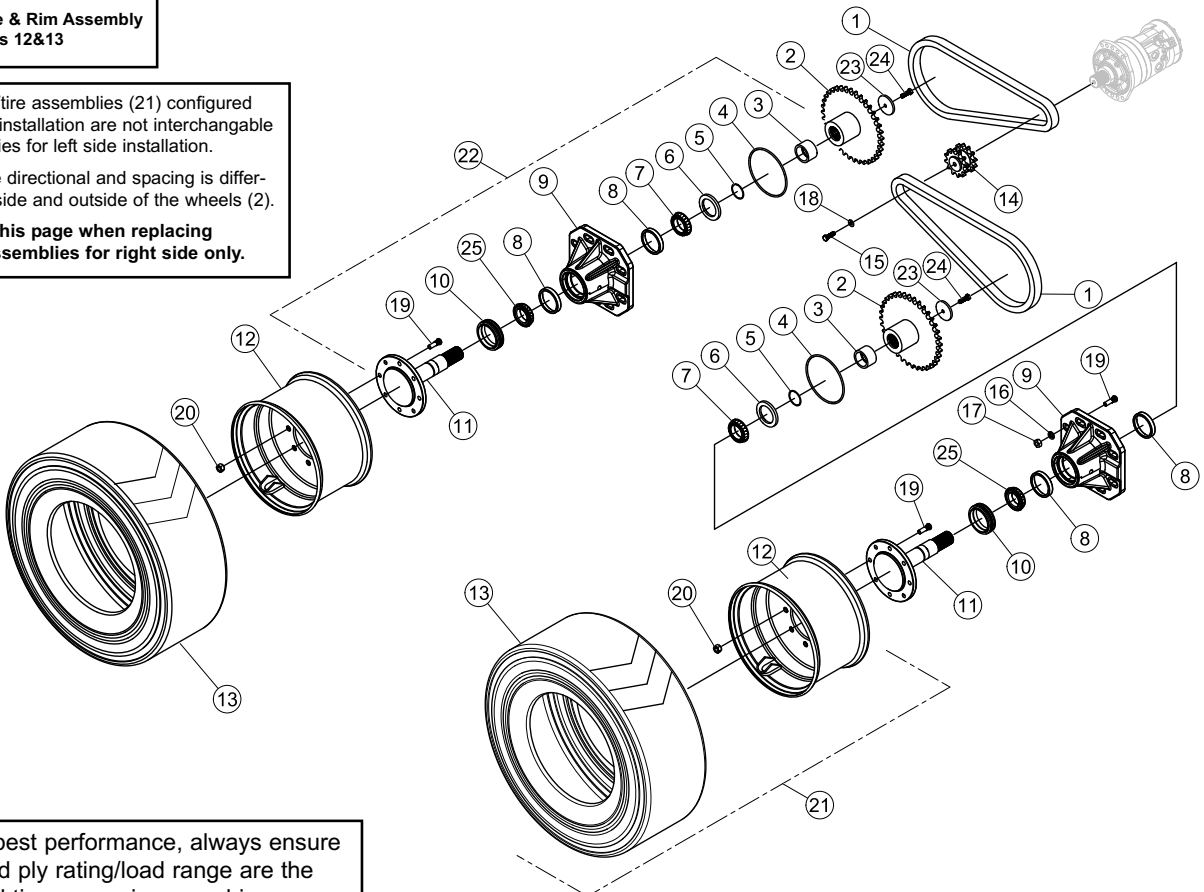

**Note:** For best performance, always ensure tire size and ply rating/load range are the same for all tires on a given machine.

# FINAL DRIVE ASSEMBLY, LT

VS-60 Serial # Valid from 00500  
V230S Serial # Valid from 00101

Chapter 5

REF. NO.	PART NUMBER	QTY.	DESCRIPTION	REF. NO.	PART NUMBER	QTY.	DESCRIPTION
1	7000-215	2	CHAIN # 80				
2	7000-217	2	WLMT SPROCKET DRIVEN 80 CHAIN				
3	7000-069	2	SLEEVE HUB MID				
4	7005-062	2	O-RING 2-366 N-70				
5	7005-061	2	O-RING 2-139 N70				
6	7005-060	2	SEAL LIP 70x100x10				
7	7005-057	4	BEARING CONE 389				
8	7005-055	4	BEARING CUP 382A				
9	7000-260	2	HOUSING MACHINED MID				
10	7005-058	2	SEAL FLOATING				
11	7000-067	2	AXLE MACHINED MID				
12	7000-989	2	RIM 16.5x8.25				
13	7000-913	2	TIRE 10.00-16.5 R4 10 Ply SKS				
14	7000-216	2	WLMT SPROCKET DRIVE # 80				
15	0200-337	1	CAPSCREW,HH,M12x1.75x40MM,GR8.8				
16	0090-302	16	Washer, M14 DIN6916 Structural				
17	0090-303	16	NUT,HEX,9/16-18 UNF,ZN				
18	8050-282	1	WASHER,WROUGHT,3/8,STD,ZN				
19	0090-458	32	STUD WHEEL				
20	PH0181-2BP	32	NUT - 9/16-18NF, 90 DEG.TAPER, GR.5				
21	SEE LIST	2	WHEEL/TIRE ASSEMBLY				
22	7000-065	2	ASSEMBLY POD MID SIZE (INCLUDES LUG NUTS, ITEM 20)				
23	7000-059	2	WASHER 1.060" x 2.5 x .25				
24	0090-254	2	WCAPSCREW HH M16-2 x 55MM 10.9				
25	7005-056	2	BEARING CONE 387A				

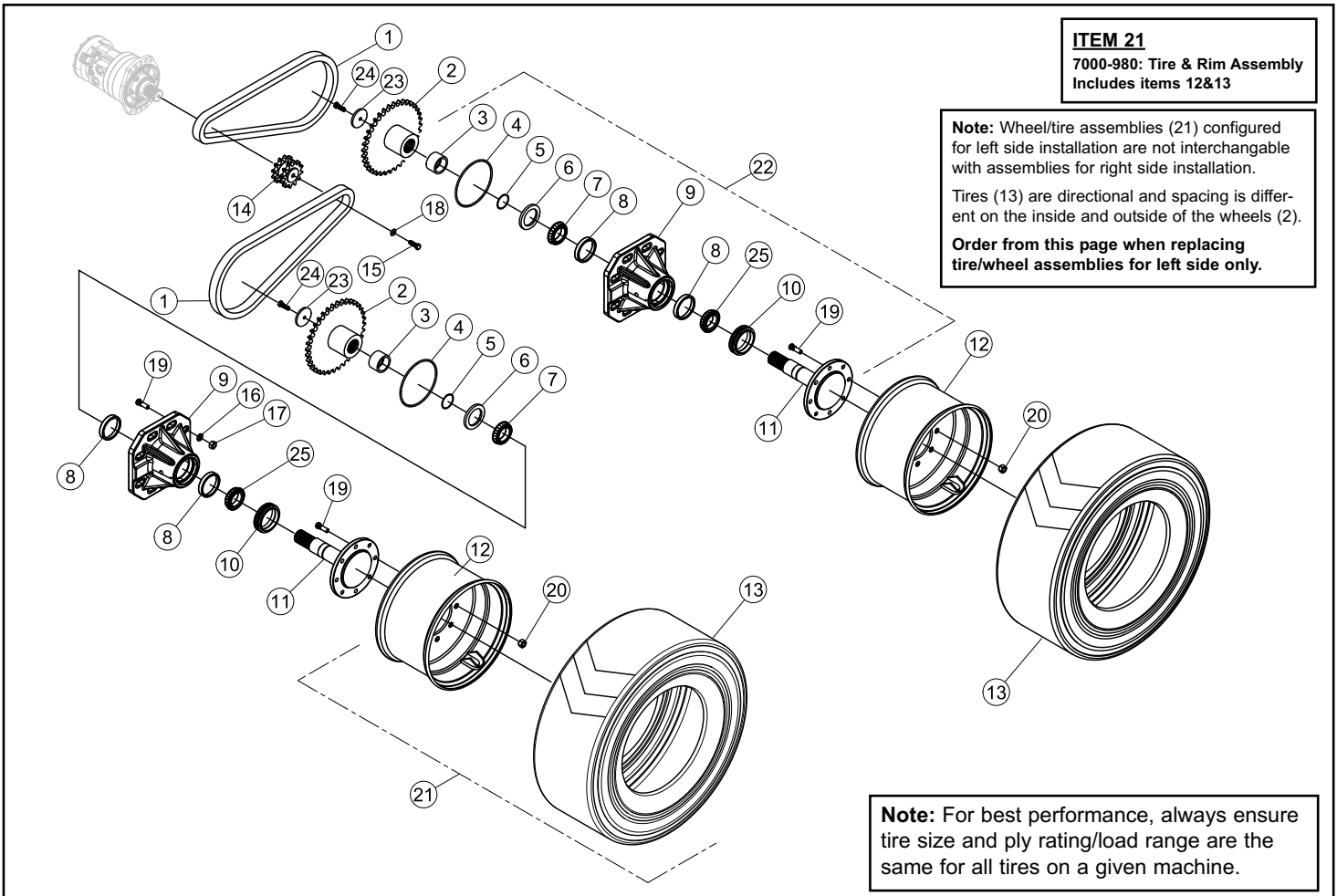

# Chapter 6

## Mainframe

### **6-1 Chassis / Fuel Tank**

VS-60 Serial # valid from - 00500 **6-1A**

V230S Serial # valid from - 00101 **6-1A**

### **6-2 Hood Assembly**

VS-60 Serial # valid from - 00500 **6-2A**

V230S Serial # valid from - 00101 **6-2A**

**\* Parts manuals are updated on a regular basis. Always refer to current online posted manuals to ensure you have the most up to date information prior to ordering parts.**

**NOTE:** Ordering parts that are painted requires a specific part number format. Please refer to page II of this manual for paint code and ordering information.

# CHASSIS / FUEL TANK

VS-60 Serial # Valid from 00500  
V230S Serial # Valid from 00101

Chapter6

REF. NO.	PART NUMBER	QTY.	DESCRIPTION	REF. NO.	PART NUMBER	QTY.	DESCRIPTION
1	7001-001	1	WLMT CHASSIS VERTICAL MF	41	8102-042	3	CAPSCREW, HH 1/4-20UNC 1"
2	7000-015	3	SSL, MF, CHAIN CASE, COVER	42	8040-396	3	NUT,HEX,NYLOCK,1/4-28 UNF,ZN
3	0090-461	24	CAPSCREW HH NON-SERRATED FLANGE				
4	7001-214	2	PADDING				
5	0090-460	24	WASHER 3/8" x 1.125" RUBBER BONDED				
6	8050-222	2	WASHER,WROUGHT,1/4,STD,ZN				
7	7000-109	3	BRACKET FUEL TANK				
8	8102-220	6	CAPSCREW,HH,3/8-16x0.75",GD8				
9	7000-455	1	FUEL TANK (Includes items-12,13,29,30,31,32)				
10	2045-407	1	CAP FUEL GREEN				
11	2075-953	1	NECK FILLER FUEL ALUMINUM				
12	0090-102	2	ADAPTER INSERT 1/2" 90°				
13	2046-171	2	GROMMET, DAPCO, 5/8"				
14	7000-013	1	SSL, MF, FLOOR PAN				
15	7000-563	1	MAT FLOOR MID FRAME				
16	2045-571	1	WLMT PEDAL THROTTLE				
17	2045-666	1	COVER THROTTLE PEDAL MACHINED				
18	8102-042	4	CAPSCREW, HH 1/4-20UNC 1" GD8				
19	8102-040	6	CAPSCREW,HH,1/4-20 UNCx.75,GD8 ZN				
20	8051-212	6	WASHER,SPRING LOCK,1/4,ZN				
21	2030-357	2	WASHER COMPOSITE				
22	2030-360	2	BELLEVILLE WASHER, 3/8" ID X 1-1/8 OD				
23	8040-486	2	NUT,HEX,NYLOCK,3/8-16 UNC,ZN				
24	8040-366	2	NUT,HEX,NYLOCK,1/4-20 UNC,ZN				
25	8102-136	2	CAPSCREW,HH,5/16-18x1.75 ZN GD8				
26	8050-262	2	WASHER,WROUGHT,5/16,STD,ZN				
27	8041-457	2	NUT,NYLOCK,5/16 - 18,THIN				
28	7000-930	1	WLMT DOOR LATCH MF				
29	0090-249	3	GROMMET, DAPCO, 3/8"				
30	0090-332	1	90 elbow, 1/4" hose				
31	0090-335	1	BALL VALVE,180 DEG.				
32	0090-333	1	90 elbow 5/16 hose				
33	4046-060	2	LIGHT WORK REAR MODULE 70				
34	0304-478	1	HORN - 164-9425				
35	7001-113	1	LOCKOUT LOADER ARM				
36	0201-477	2	PIN,LOCKING,D-RING,3.00"				
37	7000-929	1	SPRING LATCH DOOR				
38	7000-933	1	PLATE HANDLE				
39	0090-015	1	BOLT SHOULDER 3/8 x3 /8 GR 8				
40	0400-964	1	ALARM, BACKUP - 107 db				

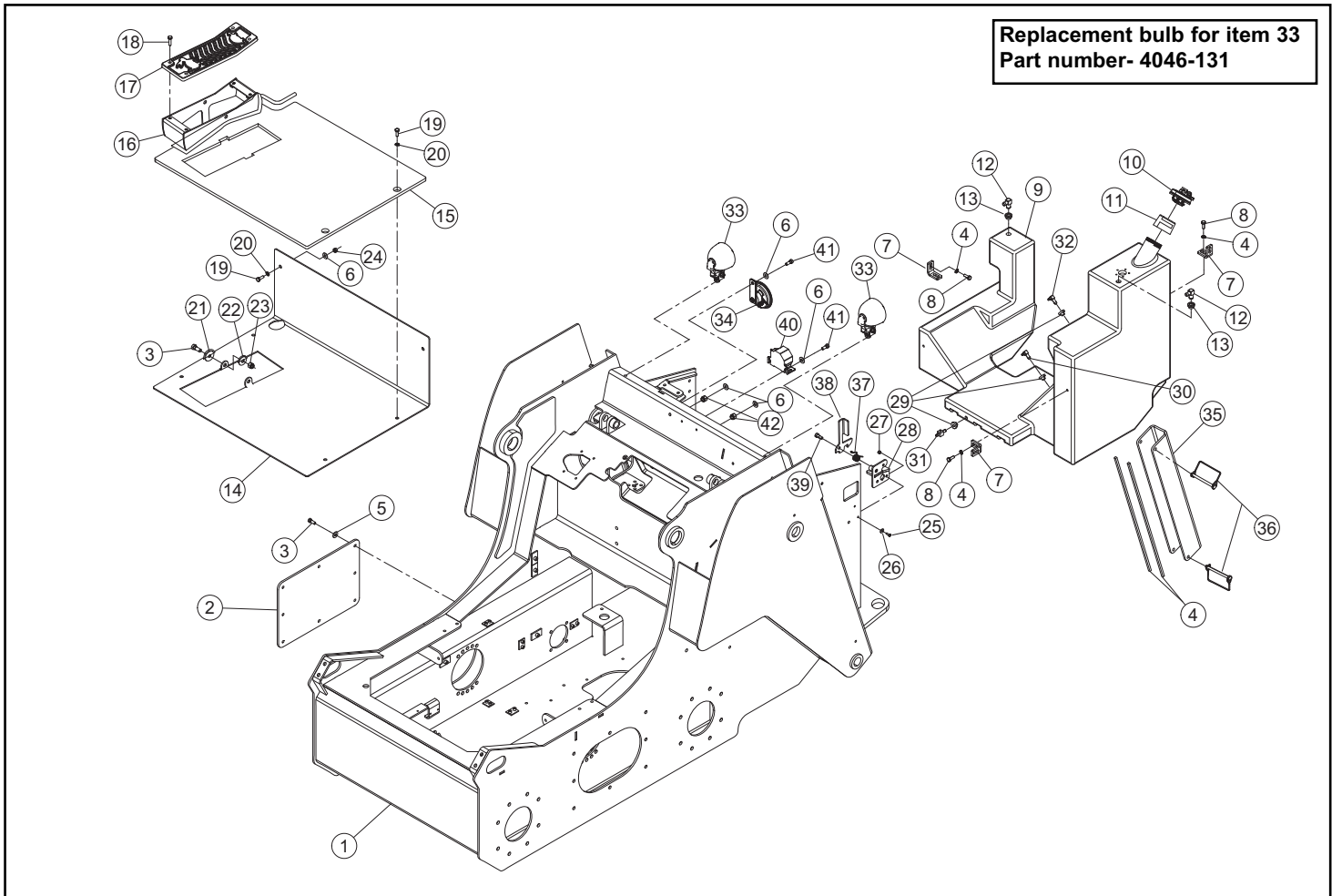

# HOOD ASSEMBLY

VS-60 Serial # Valid from 00500  
V230S Serial # Valid from 00101

Chapter 6

REF. NO.	PART NUMBER	QTY.	DESCRIPTION
1	7001-345	1	WLMT REAR DOOR BENT
2	7000-116	1	SCREEN DOOR REAR
3	8102-222	2	CAPSCREW,HH,3/8-16 UNCx1.0,GD8,ZN
4	8050-262	16	WASHER,WROUGHT,5/16,STD,ZN
5	8040-426	14	NUT,HEX,NYLOCK,5/16-18 UNC,ZN
6	7000-079	1	WELDMNT, TOP HOOD
7	7000-390	1	SCREEN, TOP HOOD
8	7000-934	1	WLMT STRIKER
9	8102-039	4	CAPSCREW,HH,1/4-20UNCx.625,GD8
10	8051-212	4	WASHER,SPRING LOCK,1/4,ZN
11	7000-389	2	PLATE, SCREEN SANDWICH, TOP HOOD
12	0304-484	1	TRIM EDGE TL-3100-B3 x 3/16-C- 88"
13	7001-217	1	ROD PROP SLOTTED
14	0090-688	2	BOLT SHOULDER 3/8" x 1/2" x 5/16"-18
15	2040-056	2	PLATE HINGE
16	8111-224	4	BOLT,CARRIAGE,3/8-16UNCx1.25,G
17	8050-282	4	WASHER,WROUGHT,3/8,STD,ZN
18	8040-486	4	NUT,HEX,NYLOCK,3/8-16 UNC,ZN

REF. NO.	PART NUMBER	QTY.	DESCRIPTION

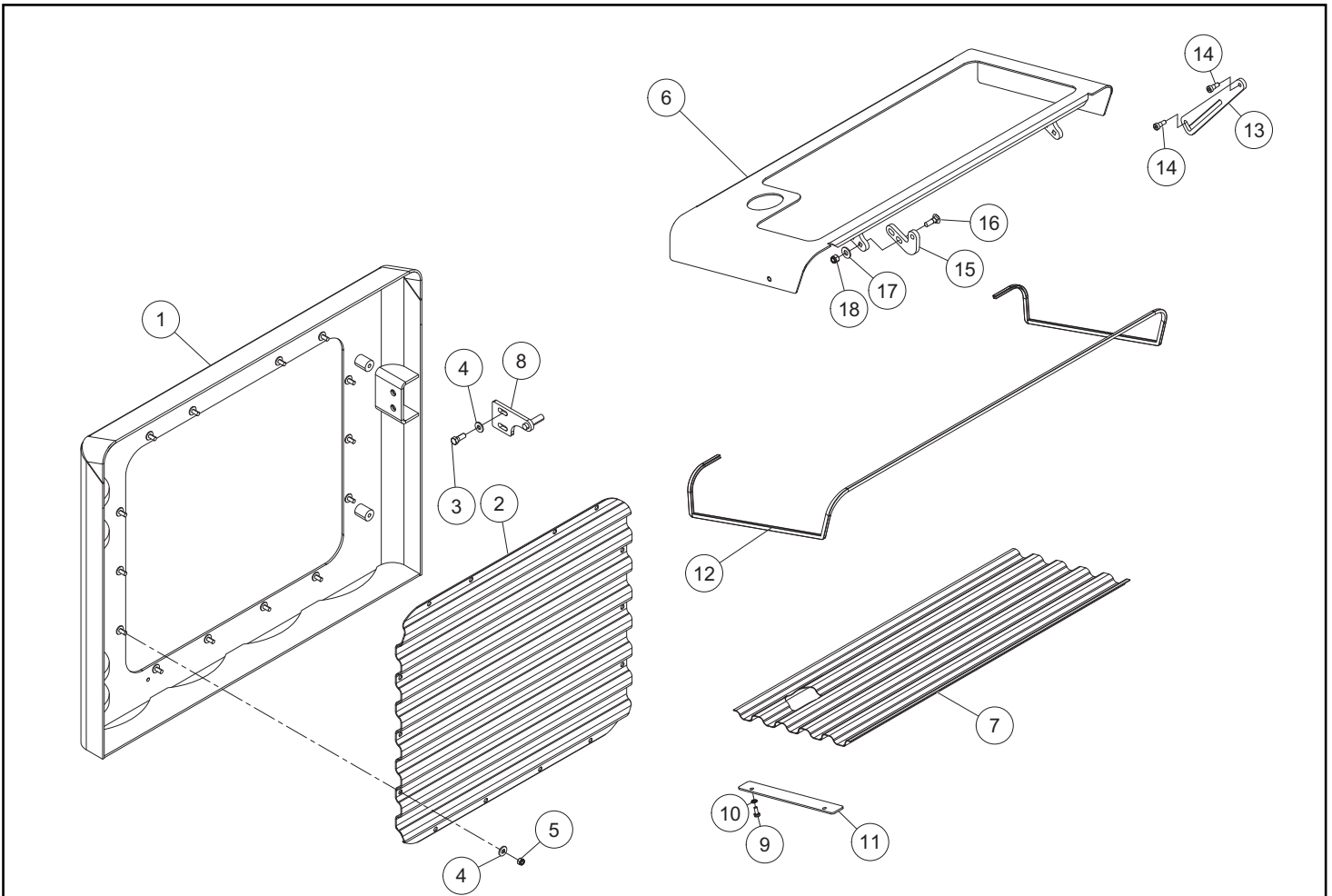

# Chapter 7

## Cab / Heating / Air Conditioning

### 7-1 Cab

VS-60 Serial # valid from - 00500 **7-1A**

V230S Serial # valid from - 00101 **7-1A**

### 7-2 Cab Interior

VS-60 Serial # valid from - 00500 **7-2A**

V230S Serial # valid from - 00101 **7-2A**

### 7-3 Headliner / Dash

VS-60 Serial # 00500 - 00505 **7-3A**

V230S Serial # 00101 - 00517 **7-3A**

VS-60 Serial # 00506 - 00745 **7-3B**

V230S Serial # 00518 - 00745 **7-3B**

VS-60 Serial # valid from - 00746 **7-3C**

V230S Serial # valid from - 00746 **7-3C**

### 7-4 Door / Windows

VS-60 Serial # valid from - 00500 **7-4A**

V230S Serial # valid from - 00101 **7-4A**

### 7-5 Wiper Assembly

VS-60 Serial # valid from - 00500 **7-5A**

V230S Serial # valid from - 00101 **7-5A**

### 7-6 Heater

VS-60 Serial # valid from - 00500 **7-6A**

V230S Serial # valid from - 00101 **7-6A**

### 7-7 Air Conditioning / Heating

VS-60 Serial # valid from - 00500 **7-7A**

V230S Serial # valid from - 00101 **7-7A**

### 7-8 Air Conditioning / Heating Unit

VS-60 Serial # valid from - 00500 **7-8A**

V230S Serial # valid from - 00101 **7-8A**

**\* Parts manuals are updated on a regular basis. Always refer to current online posted manuals to ensure you have the most up to date information prior to ordering parts.**

**NOTE:** Ordering parts that are painted requires a specific part number format. Please refer to page II of this manual for paint code and ordering information.

# R.O.P.S (CAB) ASSEMBLY

VS-60 Serial # Valid from 00500  
V230S Serial # Valid from 00101

Chapter 7

REF. NO.	PART NUMBER	QTY.	DESCRIPTION	REF. NO.	PART NUMBER	QTY.	DESCRIPTION
1	7005-175	1	ROPS (3P Cab)	41	8041-457	1	NUT,NYLOCK,5/16 - 18,THIN
2	7005-568	1	GLASS SIDE PANEL	42	0090-137	1	BOLT 3/8" SHLDR x1/2"x5/16"-18
3	0090-300	7	INSERT THREADED FLHD 1/4-20	43	1066-002	1	FOAM STRIP,ADHES BACK, 4"
4	7005-569	1	SEAL GLASS SIDE PANEL	44	1066-002	1	FOAM STRIP,ADHES BACK, 7 1/2"
5	0201-748	1	ASSY,TAG,EMERGENCY EXIT	45	0090-065	4	PIN LYNCH 3/16 DIA x 1 9/16
6	2075-822	1	WINDOW REAR 16.25 X 23.25	46	0090-430	2	PIN ROPS
7	0090-347	10	SCREW TH PH 1/4-20 X 1.25 ZN	47	0090-407	1	BULB SEAL 1.00 X 1.00 X 65"
8	0090-325	10	WASHER 1/4" 3/4" RUBBER BONDED GALVANIZE				
9	2030-671	1	FRAME WINDOW TOP				
10	0200-606	1	PANEL ROOF LEXAN				
11	0200-607	1	SEAL PANEL ROOF				
12	8102-039	2	CAPSCREW,HH,1/4-20UNCx.625,GD8				
13	8051-212	10	WASHER,SPRING LOCK,1/4,ZN				
14	8050-222	21	WASHER,WROUGHT,1/4,STD,ZN				
15	7006-011	1	RETAINER WIRING HARNESS				
16	8040-366	24	NUT,HEX,NYLOCK,1/4-20 UNC,ZN				
17	8050-222	24	WASHER,WROUGHT,1/4,STD,ZN				
18	0090-403	14	CAPSCREW,HH,1/4-20 UNCx.75,GD8 ZN				
19	7000-468	3	CLAMP PILOT LINE SMALL				
20	7000-469	2	CLAMP PILOT LINE SMALL				
21	7005-820	2	LIGHT WORK CE APPROVED				
22	0090-368	2	WASHER,WROUGHT,1/2,STD,ZN				
23	8051-332	2	WASHER,SPRING LOCK,1/2,ZN				
24	8102-405	2	CAPSCREW,HH,1/2-13 UNCx1.5,GD8				
25	8011-132	2	BOLT,CARRIAGE,5/16-18 UNCx1.0				
26	8051-242	2	WASHER,SPRING LOCK,5/16,ZN				
27	8042-363	2	NUT,HEX 5-16-18 UNC ZN				
28	0090-532	7ft	SEAL .125 OFFSET WINDOW LOCKING W/ZIPPER				
29	0090-533	7ft	SEAL FILLER STRIP				
30	8102-228	1	CAPSCREW,HH,3/8-16UNCx2.25"GR8				
31	8050-262	2	WASHER,WROUGHT,5/16,STD,ZN				
32	2076-147	1	SPACER GUARD FAN				
33	8041-500	1	NUT,HEX,NYLOCK,3/8-16 UNC,THIN				
34	7001-145	2	SPRING GAS 2200N				
35	8102-140	1	CAPSCREW,HH,5/16-18UNCx2.75 GR8				
36	8040-426	1	NUT,HEX,NYLOCK,5/16-18 UNC,ZN				
37	8040-426	1	NUT,HEX,NYLOCK,5/16-18 UNC,ZN				
38	0090-104	1	WASHER .402 x .728 x .098 HARD				
39	2095-940	1	ROD PROP SLOTTED				
40	8102-040	1	CAPSCREW,HH,1/4-20 UNCx.75,GD8 ZN				

Replacement bulb for item 21  
Part number- 0404-394

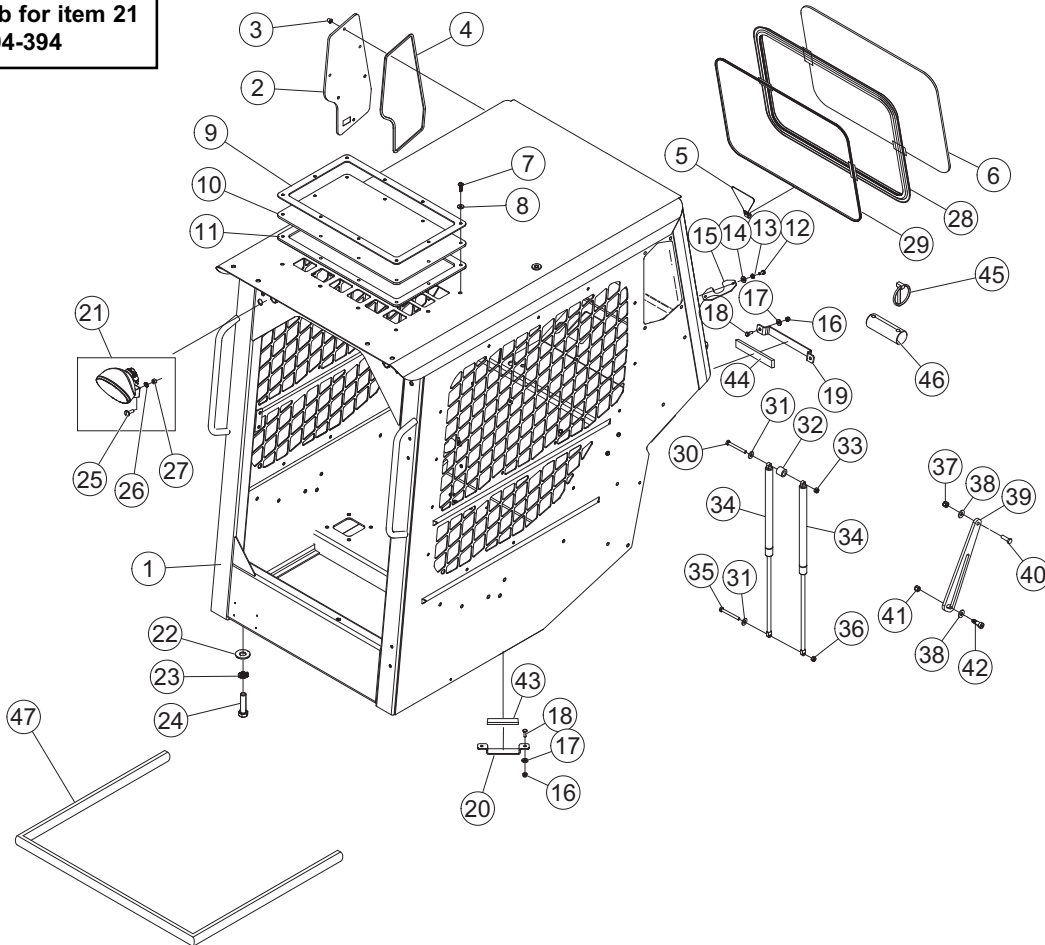

# R.O.P.S (CAB) INTERIOR

VS-60 Serial # Valid from 00500  
V230S Serial # Valid from 00101

Chapter 7

REF. NO.	PART NUMBER	QTY.	DESCRIPTION	REF. NO.	PART NUMBER	QTY.	DESCRIPTION
1	2075-832	1	BIN STORAGE				
2	2045-636	3	NET CARGO				
3	7005-780	1	PANEL FRONT LH				
4	2076-054	1	CUPHOLDER				
5	0090-305	8	RETAINER PUSH TYPE .250 DIA				
6	7005-779	1	PANEL REAR RH				
7	2075-102	1	COVER FUSE PANEL				
8	7005-782	1	PANEL FRONT LH WASHER TANK				
9	7005-778	1	PANEL REAR LH				
10	0304-019	1	ASSY,LAP BAR				
11	7005-192	2	LAPBAR STOP, LH				
12	2045-452	1	SEAT,SUSP,60MM				
13	0200-264	1	HOUSING,POWER SOURCE				
14	0200-265	1	CAP,HOUSING,POWER SOURCE				
15	8040-606	4	NUT,HEX,NYLOCK,1/2-13 UNC,ZN				
16	8102-404	4	CAPSCREW,HH,1/2-13UNCx1.25 GD8 ZN				
17	8102-040	4	CAPSCREW,HH,1/4-20 UNCx.75,GD8 ZN				
18	8060-648	2	RIVET,BLIND,3/16 x .575				
19	2075-939	1	STOP LAPBAR RH				
20	8050-222	4	WASHER,WROUGHT,1/4,STD,ZN				
21	8040-366	4	NUT,HEX,NYLOCK,1/4-20 UNC,ZN				
22	8040-426	4	NUT,HEX,NYLOCK,5/16-18 UNC,ZN				
23	8050-262	4	WASHER,WROUGHT,5/16,STD,ZN				
24	2076-409	1	BELT,SEAT 2" ADJUSTABLE				
25	2045-481	2	TETHER,SEAT				
26	0090-397	4	CAPSCREW HCS 7/16-14x1 Z8				
27	8050-282	8	WASHER,WROUGHT,3/8,STD,ZN				
28	8040-546	4	NUT,HEX,NYLOCK,7/16-14 UNC,ZN				
29	0403-712	1	BOTTLE WASHER				
30	0403-715	1	CAP WASHER RESERVOIR				
31	0090-128	8	SCREW TH PH 10-24 x 5 SS				
32	0090-117	13	CAPSCREW TH PH 10-24 X .75 SS				
33	0304-515	1	SWITCH,SEAT (OLD STYLE)				
34	0304-473	1	SENSOR,SWITCH,LAPBAR S17040				
35	0310-307	2	SCREW,MACHINE,4-40x.50				
36	0310-308	2	NUT,HEX,NYLOCK 4-40				
37	8051-212	4	WASHER,SPRING LOCK,1/4,				
38	8102-042	4	CAPSCREW, HH 1/4-20UNC 1" GD8				
39	7000-854	2	MOUNT INTERIOR LOWER				

**NOTE: Service item for lap bar assembly  
Part number- 0304-471 SPRING,GAS,ASSIST**

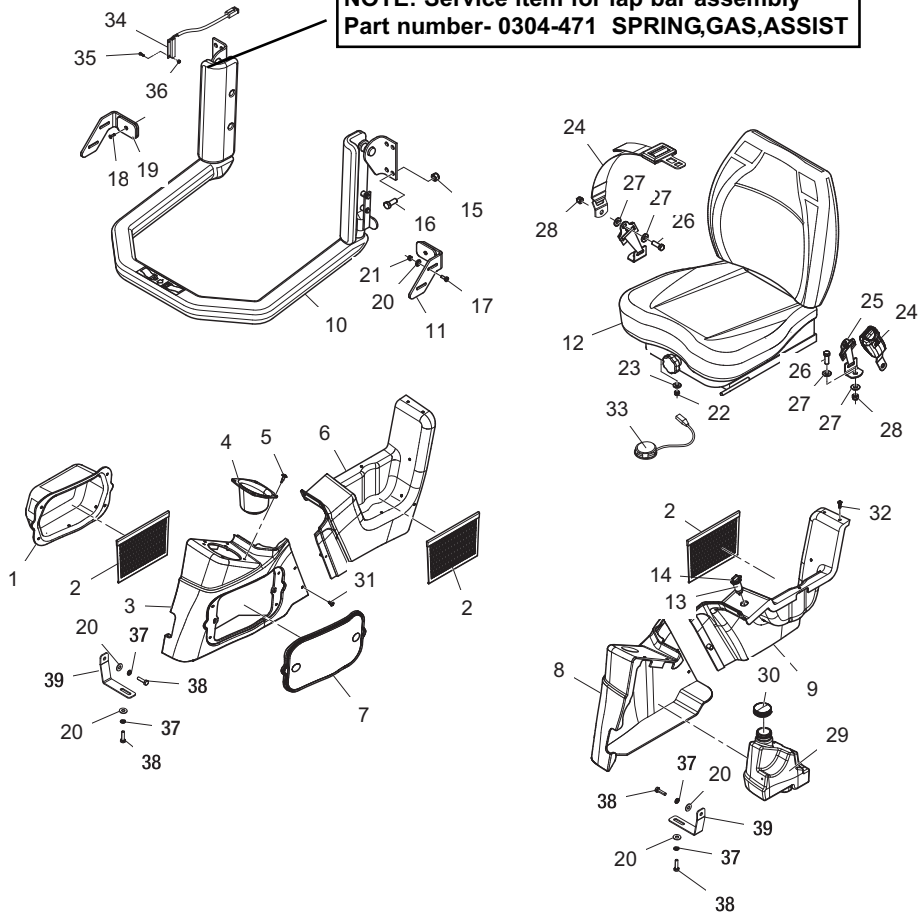

# HEADLINER / DASH PANEL

VS-60 Serial # 00500-00505  
V230S Serial # 00101-00517

Chapter 7

REF. NO.	PART NUMBER	QTY.	DESCRIPTION	REF. NO.	PART NUMBER	QTY.	DESCRIPTION
1	2076-305	1	HEADLINER HEAT A/C	41	7005-826	1	PANEL GAUGE
2	0090-305	16	RETAINER PUSH TYPE .250 DIA	42	7000-675	1	DECAL SWITCH POD STYLE DASH SSL
3	2075-637	1	LIGHT DOME	43	7000-674	1	DECAL POWER QUICK ATTACH SSL
4	2075-703	2	SPEAKER MINI 3.5" HEAVY DUTY	44	2075-749	1	*INDICATOR RABBIT/GLOW PLUG
5	8008-222	8	SCREW MACH #6-32X1.0 PH PAN	45	7005-783	1	MOUNT ANGLE MIRROR
6	0090-270	8	T-NUT 6-32 UNC ZN				
7	2076-284	1	HVAC MOUNT PLATE				
8	2076-241	1	SWITCH A/C				
9	2095-873	2	KNOB CONTROL				
10	2075-702	1	RADIO MINI WP AM/FM/WX BAND				
11	2075-821	2	PLATE MOUNTING HVAC CONTROL				
12	2076-047	1	MOUNT RADIO				
13	8008-217	6	SCREW,MACH#6-32x0.5,PH,PAN				
14	2045-477	1	SWITCH SELF LEVELER				
15	0310-136	4	FRAME,END VME-01 INDEX # 536-11583-001				
16	2045-413	1	SWITCH LOCKING PARK				
17	0310-133	1	SWITCH,BEACON V1D2BNOC-A9C63-100-XAS1				
18	0310-126	1	SWITCH,LIGHT VAD2BNOC-A9C45-100-XAS1				
19	0310-137	3	FRAME,MID IMM-01				
20	2045-725	2	SWITCH 2 POSITION LOCKING W/ RED BUTTON				
21	0200-252	2	SWITCH,3 POSITION,LOCKING				
22	2045-502	1	METER HOUR				
23	0090-370	4	CAPSCREW HH 1/4-20 UNCx.75 GD5 BLK				
24	0090-371	4	WASHER SPRING LOCK 1/4 BLK ZN				
25	4030-127	1	*GAUGE FUEL WITH WARNINGS				
26	4030-128	1	*GAUGE TACHOMETER 2"				
27	4030-130	1	*GAUGE WATER TEMP 2"				
28	4030-129	1	*GAUGE WARNING INDICATION				
29	0304-028	1	SWITCH,IGNITION,RC 154-3197				
30	2045-792	1	COVER KEY IGNITION				
31	0090-372	4	WASHER WROUGHT 1/4 STD BLK ZN				
32	2076-285	1	HVAC DECAL				
33	2045-899	1	SWITCH 3 SPEED				
34	2045-432	2	KEY IGNITION				
35	2075-816	1	CONTROLLER TEMP				
36	8050-222	6	WASHER,WROUGHT,1/4,STD,ZN				
37	2030-409	1	MIRROR REAR VIEW 3X8				
38	8040-366	1	NUT,HEX,NYLOCK,1/4-20 UNC,ZN				
39	8102-039	1	CAPSCREW,HH,1/4-20UNCx.625,GD8				
40	2075-704	1	ANTENNA 6" MINI				

For kit information, please see page 10-1A

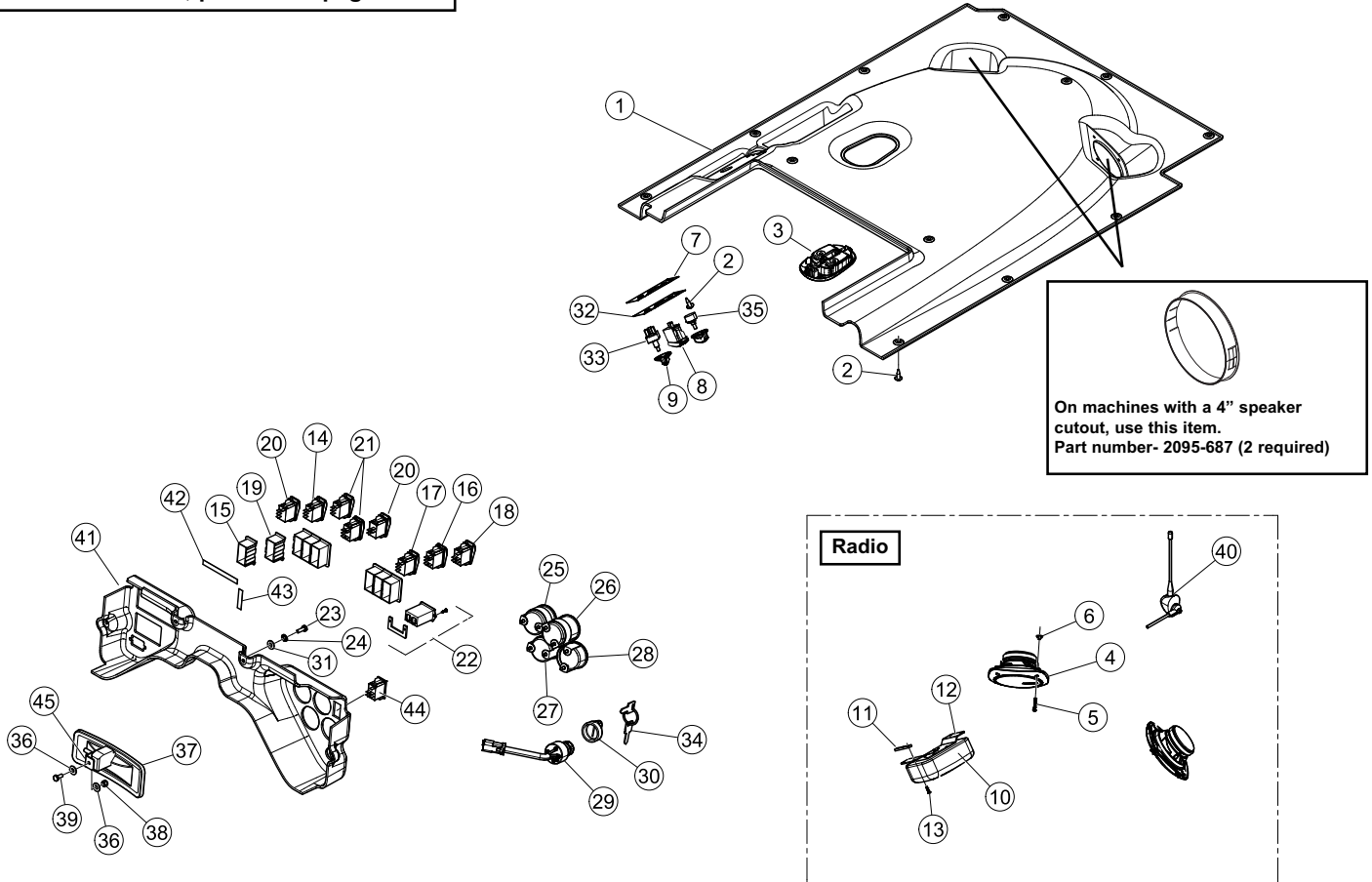

# HEADLINER / DASH PANEL

VS-60 Serial # 00506-00745  
V230S Serial # 00518-00745

Chapter 7

REF. NO.	PART NUMBER	QTY.	DESCRIPTION	REF. NO.	PART NUMBER	QTY.	DESCRIPTION
1	2076-305	1	HEADLINER HEAT A/C	41	7005-826	1	PANEL GAUGE
2	0090-305	16	RETAINER PUSH TYPE .250 DIA	42	7000-675	1	DECAL SWITCH POD STYLE DASH SSL
3	2075-637	1	LIGHT DOME	43	7000-674	1	DECAL POWER QUICK ATTACH SSL
4	2075-703	2	SPEAKER MINI 3.5" HEAVY DUTY	44	2075-749	1	*INDICATOR RABBIT/GLOW PLUG
5	8008-222	8	SCREW MACH #6-32X1.0 PH PAN	45	7005-783	1	MOUNT ANGLE MIRROR
6	0090-270	8	T-NUT 6-32 UNC ZN				
7	2076-284	1	HVAC MOUNT PLATE				
8	2076-241	1	SWITCH A/C				
9	2095-873	2	KNOB CONTROL				
10	2075-702	1	RADIO MINI WP AM/FM/WX BAND				
11	2075-821	2	PLATE MOUNTING HVAC CONTROL				
12	2076-047	1	MOUNT RADIO				
13	8008-217	6	SCREW,MACH#6-32x0.5,PH,PAN				
14	2045-477	1	SWITCH SELF LEVELER				
15	0310-136	4	FRAME,END VME-01 INDEX # 536-11583-001				
16	2045-413	1	SWITCH LOCKING PARK				
17	0310-133	1	SWITCH,BEACON V1D2BNOC-A9C63-100-XAS1				
18	0310-126	1	SWITCH,LIGHT VAD2BNOC-A9C45-100-XAS1				
19	0310-137	3	FRAME,MID IMM-01				
20	2045-725	2	SWITCH 2 POSITION LOCKING W/ RED BUTTON				
21	0200-252	2	SWITCH,3 POSITION,LOCKING				
22	2045-502	1	METER HOUR				
23	0090-370	4	CAPSCREW HH 1/4-20 UNCx.75 GD5 BLK				
24	0090-371	4	WASHER SPRING LOCK 1/4 BLK ZN				
25	4030-127	1	*GAUGE FUEL WITH WARNINGS				
26	4030-128	1	*GAUGE TACHOMETER 2"				
27	2030-303	1	PLUG FINISHING 2" HEYCO 3050				
28	4030-129	1	*GAUGE WARNING INDICATION				
29	0304-028	1	SWITCH,IGNITION,RC 154-3197				
30	2045-792	1	COVER KEY IGNITION				
31	0090-372	4	WASHER WROUGHT 1/4 STD BLK ZN				
32	2076-285	1	HVAC DECAL				
33	2045-899	1	SWITCH 3 SPEED				
34	2045-432	2	KEY IGNITION				
35	2075-816	1	CONTROLLER TEMP				
36	8050-222	6	WASHER,WROUGHT,1/4,STD,ZN				
37	2030-409	1	MIRROR REAR VIEW 3X8				
38	8040-366	1	NUT,HEX,NYLOCK,1/4-20 UNC,ZN				
39	8102-039	1	CAPSCREW,HH,1/4-20UNCx.625,GD8				
40	2075-704	1	ANTENNA 6" MINI				

For kit information, please see page 10-1A

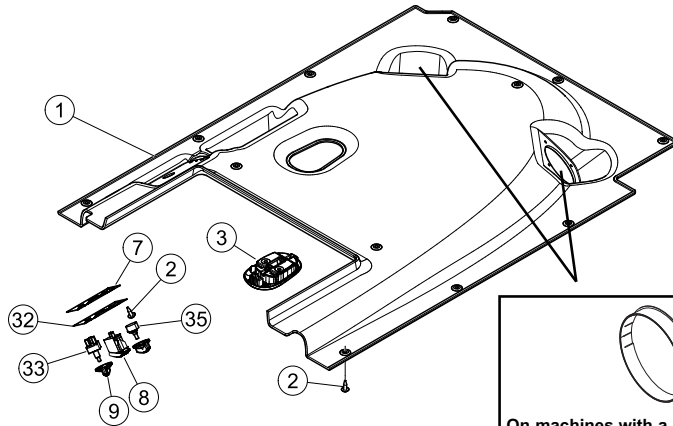

On machines with a 4" speaker cutout, use this item.  
Part number- 2095-687 (2 required)

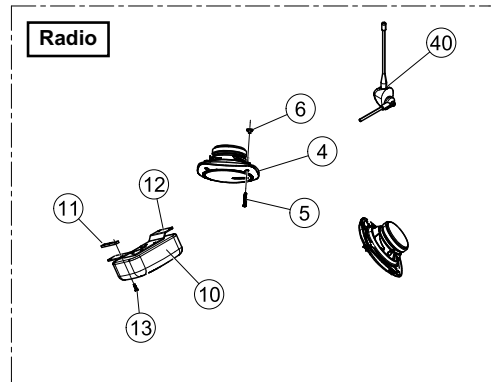
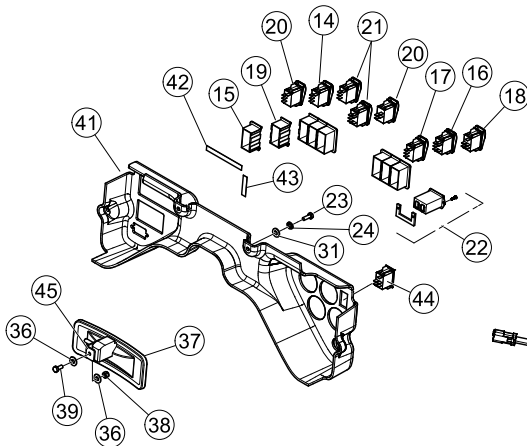

# HEADLINER / DASH PANEL

VS-60 Serial # Valid from 00746  
V230S Serial # Valid from 00746

Chapter 7

REF. NO.	PART NUMBER	QTY.	DESCRIPTION	REF. NO.	PART NUMBER	QTY.	DESCRIPTION
1	2076-305	1	HEADLINER HEAT A/C	41	7005-826	1	PANEL GAUGE
2	0090-305	16	RETAINER PUSH TYPE .250 DIA	42	7000-675	1	DECAL SWITCH POD STYLE DASH SSL
3	2075-637	1	LIGHT DOME	43	7000-674	1	DECAL POWER QUICK ATTACH SSL
4	2075-703	2	SPEAKER MINI 3.5" HEAVY DUTY	44	2075-749	1	*INDICATOR RABBIT/GLOW PLUG
5	8008-222	8	SCREW MACH #6-32X1.0 PH PAN	45	7005-783	1	MOUNT ANGLE MIRROR
6	0090-270	8	T-NUT 6-32 UNC ZN				
7	2076-284	1	HVAC MOUNT PLATE				
8	2076-241	1	SWITCH A/C				
9	2095-873	2	KNOB CONTROL				
10	2075-702	1	RADIO MINI WP AM/FM/WX BAND				
11	2075-821	2	PLATE MOUNTING HVAC CONTROL				
12	2076-047	1	MOUNT RADIO				
13	8008-217	6	SCREW, MACH #6-32x0.5, PH, PAN				
14	2045-477	1	SWITCH SELF LEVELER				
15	0310-136	4	FRAME, END VME-01 INDEX # 536-11583-001				
16	2045-413	1	SWITCH LOCKING PARK				
17	0310-133	1	SWITCH, BEACON V1D2BNOC-A9C63-100-XAS1				
18	0310-126	1	SWITCH, LIGHT VAD2BNOC-A9C45-100-XAS1				
19	0310-137	3	FRAME, MID IMM-01				
20	2045-725	2	SWITCH 2 POSITION LOCKING W/ RED BUTTON				
21	0200-252	2	SWITCH, 3 POSITION, LOCKING				
22	2045-502	1	METER HOUR				
23	0090-370	4	CAPSCREW HH 1/4-20 UNCx.75 GD5 BLK				
24	0090-371	4	WASHER SPRING LOCK 1/4 BLK ZN				
25	4030-227	1	GAUGE, 2" FUEL, MAXIMATECC				
26	4030-228	1	GAUGE, 2" TACHOMETER, MAXIMATECC				
27	2030-303	1	PLUG FINISHING 2" HEYCO 3050				
28	4030-129	1	*GAUGE WARNING INDICATION				
29	0304-028	1	SWITCH, IGNITION, RC 154-3197				
30	2045-792	1	COVER KEY IGNITION				
31	0090-372	4	WASHER WROUGHT 1/4 STD BLK ZN				
32	2076-285	1	HVAC DECAL				
33	2045-899	1	SWITCH 3 SPEED				
34	2045-432	2	KEY IGNITION				
35	2075-816	1	CONTROLLER TEMP				
36	8050-222	6	WASHER, WROUGHT, 1/4, STD, ZN				
37	2030-409	1	MIRROR REAR VIEW 3X8				
38	8040-366	1	NUT, HEX, NYLOCK, 1/4-20 UNC, ZN				
39	8102-039	1	CAPSCREW, HH, 1/4-20UNCx.625, GD8				
40	2075-704	1	ANTENNA 6" MINI				

For kit information, please see page 10-1A

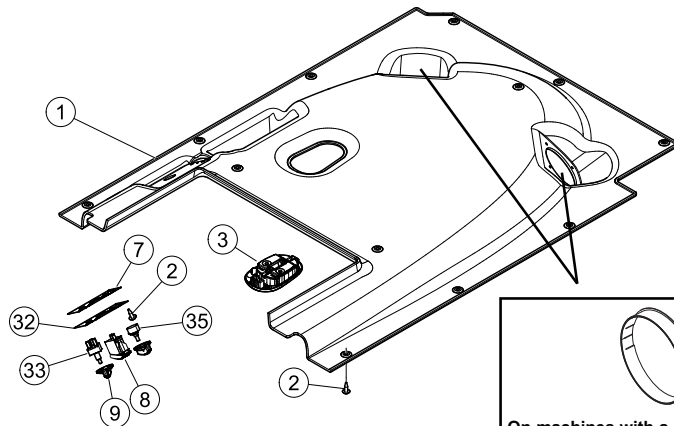

On machines with a 4" speaker cutout, use this item.  
Part number- 2095-687 (2 required)

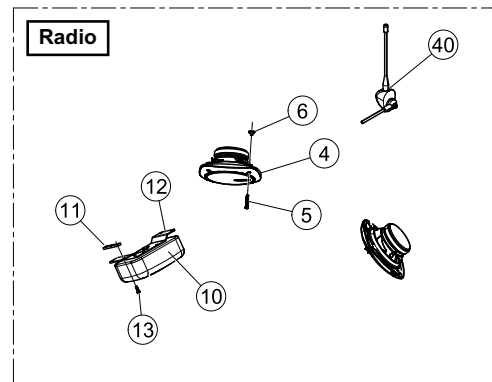
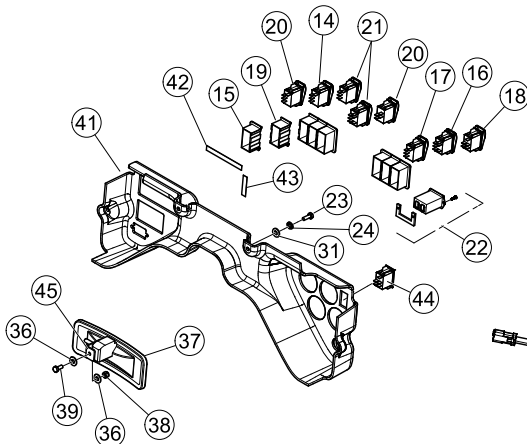

# DOOR / WINDOWS

VS-60 Serial # Valid from 00500  
V230S Serial # Valid from 00101

Chapter 7

REF. NO.	PART NUMBER	QTY.	DESCRIPTION
1	0404-344	1	WINDOW SIDE LH
2	0404-345	1	WINDOW SIDE RH
3	0090-372	26	WASHER WROUGHT 1/4 STD BLK ZN
4	0090-370	28	CAPSCREW HH 1/4-20 UNCx.75 GD5 BLK
5	0304-495	2	STUD,BALL,10MM STUD
6	0200-545	2	CLIP,SAFETY,GAS SPRING
7	0403-870	1	SPRING DAMPENED DOOR
8	0403-801	0	MOUNT DOOR SPRING
9	8040-426	9	NUT,HEX,NYLOCK,5/16-18 UNC,ZN
10	8040-366	3	NUT,HEX,NYLOCK,1/4-20 UNC,ZN
11	0090-123	10	TRIM EDGE WITH 3/8 BULB HD
12	0403-787	1	WLMT DOOR W/ HINGES
13	0201-748	1	ASSY,TAG,EMERGENCY EXIT
14	1059-015	9'	SEAL,WINDOW AS1456
15	0310-495	9'	STRIP,LOCK AS-937
16	0403-797	1	WINDOW DOOR TEMPERED GLASS
17	0304-486	1	CAPSCREW,HH,M6-1.0x14
18	8050-240	1	WASHER,STAINLESS,1/4"
19	0403-793	1	WLMT DOOR LATCH MOUNT
20	8051-242	2	WASHER,SPRING LOCK,5/16,ZN
21	2075-408	1	STRIKE
22	8050-347	2	WASHER,WROUGHT,1/2,STD,ZN
23	0090-135	1	NUT NYLOCK M12 X 1.0 ZC
24	2075-407	1	HANDLE INSIDE
25	0090-257	2	SCREW FH PH 5/16 x 1.75 ZN
26	2075-406	1	HANDLE PUSH BUTTON
27	0403-869	1	CATCH DOOR LATCH
28	8102-222	2	CAPSCREW,HH,3/8-16 UNCx1.0,GD8,ZN
29	0403-969	1	WLMT GRAB HANDLE - DOOR
30	8050-277	2	WASHER,WROUGHT,3/8,SAE,ZN
31	8040-486	2	NUT,HEX,NYLOCK,3/8-16 UNC,ZN
32	8011-132	4	BOLT,CARRIAGE,5/16-18 UNCx1.0,
33	8050-262	4	WASHER,WROUGHT,5/16,STD,ZN
34	0403-503	2	BUSHING HINGE 3-15/16 W/GRS ZRK
35	0403-481	2	ASSY HINGE DOOR CAST LH
36	0403-896	1	SWITCH DOOR PUSH BUTTON
37	8050-222	1	WASHER
38	0404-463	1	WLMT HINGE DOOR CAST W/STOP
39	0090-049	1	BUMPER, RUBBER
40	8102-042	1	CAPSCREW, HH 1/4-20UNC 1" GD8

REF. NO.	PART NUMBER	QTY.	DESCRIPTION
41	0090-622	1	MACH, PH PAN HD, M6-1.0 X 10MM CLR ZNC

For kit information, please see page 10-1A

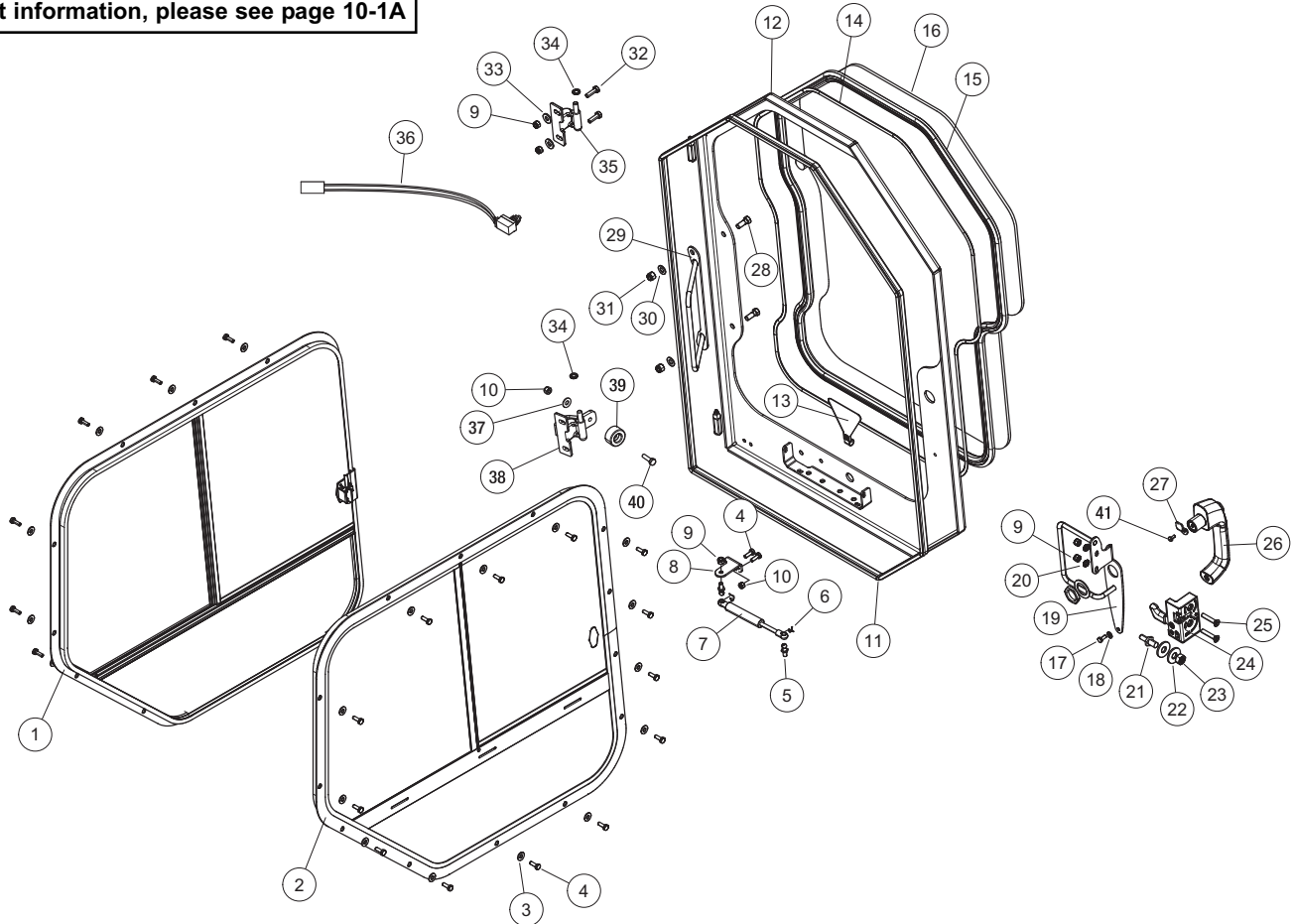

# WIPER ASSEMBLY

VS-60 Serial # Valid from 00500  
V230S Serial # Valid from 00101

Chapter 7

REF. NO.	PART NUMBER	QTY.	DESCRIPTION	REF. NO.	PART NUMBER	QTY.	DESCRIPTION
1	0403-986	1	SWITCH WIPER - 2 SPEED				
2	0403-985	1	COVER, WIPER				
3	0090-117	2	CAPSCREW TH PH 10-24 X .75 SS				
4	0403-995	1	MOTOR WIPER 45 PANTOGRAPH				
5	0403-996	1	ARM WIPER 550 MM PANTOGRAPH WET				
6	0403-997	1	BLADE WIPER 650 MM				
7	0403-998	1	CONNECTOR 90° ELBOW METAL				
8	0090-252	4	TUBING PVC 6MM OD x 4MM ID				
9	0403-757	1	COUPLER FEMALE WASHER LINE				
10	0403-756	1	COUPLER MALE WASHER LINE				
11	0403-715	1	CAP WASHER RESERVOIR				
12	0403-682	1	SWITCH WINDSHIELD WASHER				
13	0403-712	1	BOTTLE WASHER				
14	0403-713	1	PUMP WASHER RESERVOIR				
15	0090-128	6	SCREW TH PH 10-24 x 5 SS				
16	0090-163	2	NUT U 10-24 UNC				
17	2075-642	1	PANEL FRONT LH E/H W/ WASHER TANK				

For kit information, please see page 10-1A

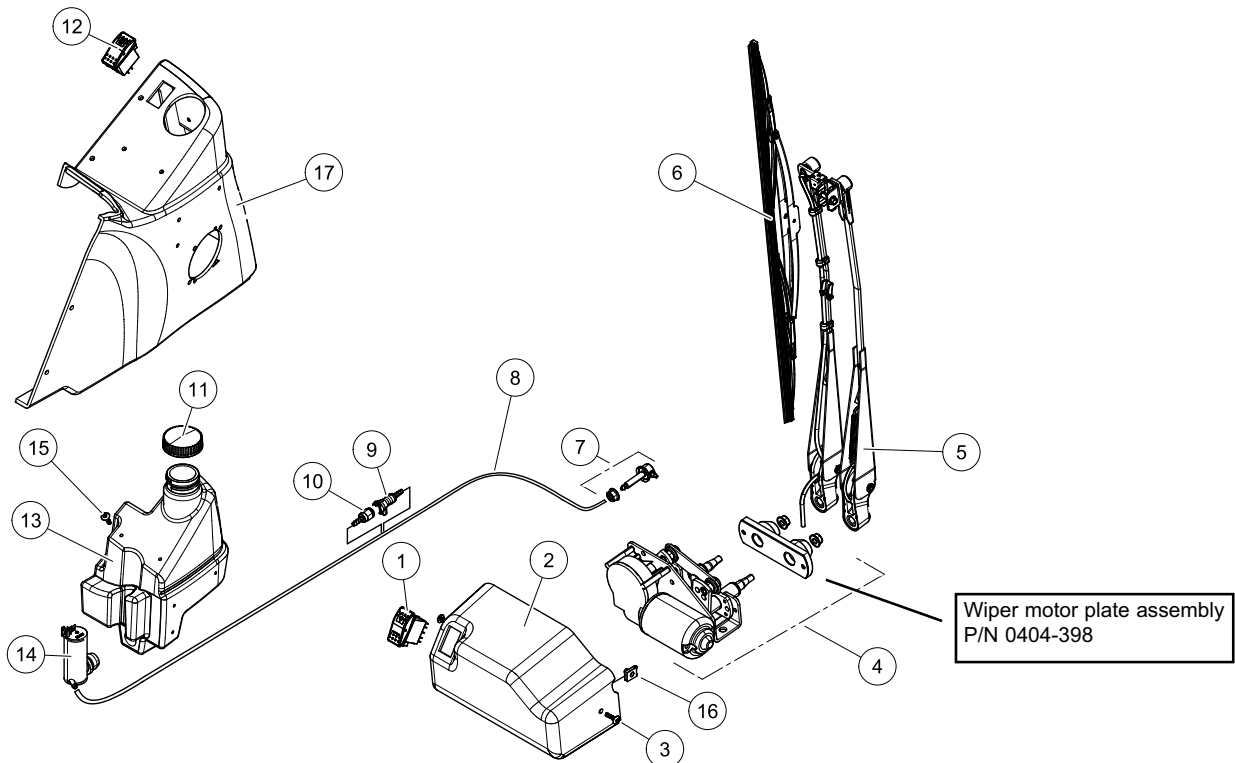

# CAB HEATER

VS-60 Serial # Valid from 00500  
V230S Serial # Valid from 00101

Chapter 7

REF. NO.	PART NUMBER	QTY.	DESCRIPTION	REF. NO.	PART NUMBER	QTY.	DESCRIPTION
1	0090-331	3	DUCT 2.5" BULK				
2	0303-175	2	HOSE,CLAMP,2.75,HI-TORQUE				
3	7000-340	1	DUCT				
4	8060-209	4	RIVET BLIND ALUM .125 X .50				
5	8050-091	4	WASHER,WROUGHT,#6,SAE,ZN				
6	2075-794	1	PLENUM INLET HVAC				
7	0090-253	8	SCREW TH PH 10-32 x 1.0 ZN				
8	8102-042	4	CAPSCREW, HH 1/4-20UNC 1" GD8				
9	0090-700	2	CAPSCREW STEEL BUTTON SOCKET HEX DRIVE ZINC				
10	8050-221	2	WASHER,FLAT,1/4,SAE				
11	8050-222	6	WASHER,WROUGHT,1/4,STD,ZN				
12	2075-812	1	COVER FRESH AIR FILTER				
13	7000-339	1	BOX FILTER				
14	2075-978	1	ASSEMBLY HVAC				
15	2045-895	4	LOUVER				
16	2075-793	1	PLENUM OUTLET HVAC				
17	8040-366	4	NUT,HEX,NYLOCK,1/4-20 UNC,ZN				
18	0301-110	5	CLAMP,HOSE,#8				
19	7000-789	1	HEAT, HOSE				
20	7001-447	1	HEAT, HOSE				
21	0304-670	1	ADAPTER,5/8BARB-3/8MPT-90^				
22	7000-789	1	HEAT, HOSE				
23	2075-987	1	VALVE WATER ELECTRONIC				
24	8102-130	2	CAPSCREW,HH 5/16-18x3/4,GR8				
25	8040-426	2	NUT,HEX,NYLOCK,5/16-18 UNC,ZN				
26	0090-500	2	ELBOW 5/8 90^				
27	7001-444	1	HOSE HEATER 5"				
28	0301-591	1	HOSE,CONNECTOR,VALVE,4"				

For kit information, please see page 10-1A

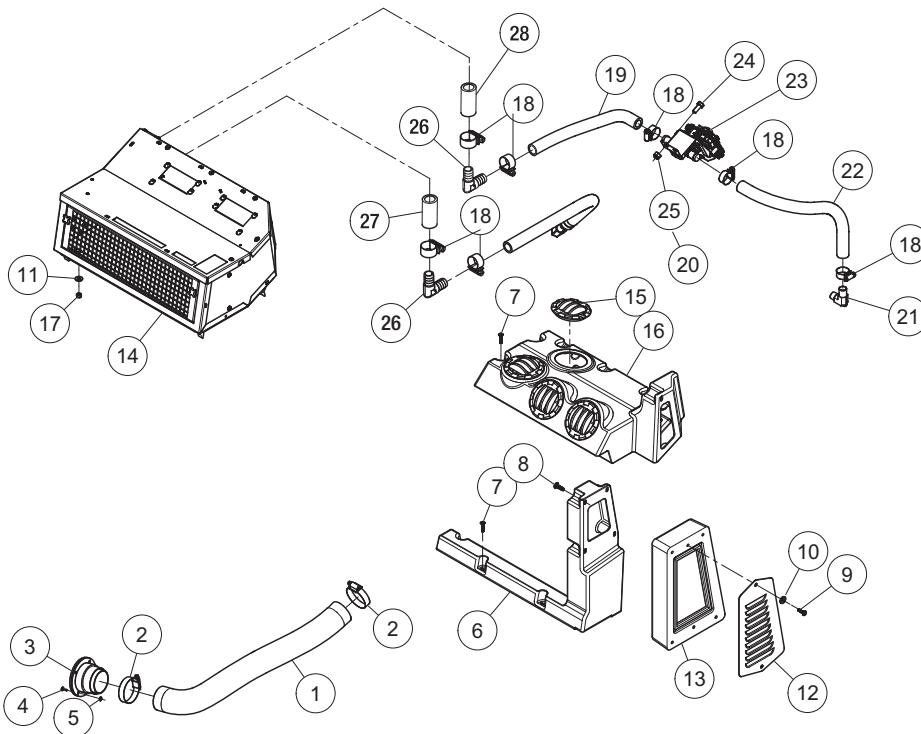

# AIR CONDITIONING / HEATING

VS-60 Serial # Valid from 00500  
V230S Serial # Valid from 00101

Chapter 7

REF. NO.	PART NUMBER	QTY.	DESCRIPTION	REF. NO.	PART NUMBER	QTY.	DESCRIPTION
1	0090-346	0.25	DUCT 3" BULK (18 FT LENGTH)	41	8050-277	2	WASHER,WROUGHT,3/8,SAE,ZN
2	0303-175	2	HOSE,CLAMP,2.75,HI-TORQUE	42	2045-889	1	SWITCH PRESSURE LOW
3	7000-340	1	DUCT				
4	8060-209	4	RIVET BLIND ALUM .125 X .50				
5	8050-091	4	WASHER,WROUGHT,#6,SAE,ZN				
6	2075-794	1	PLENUM INLET HVAC				
7	0090-253	8	SCREW TH PH 10-32 x 1.0 ZN				
8	8102-042	4	CAPSCREW, HH 1/4-20UNC 1" GD8				
9	0090-700	2	CAPSCREW STEEL BUTTON SOCKET HEX DRIVE ZINC				
10	8050-221	2	WASHER,FLAT,1/4,SAE				
11	8050-222	4	WASHER,WROUGHT,1/4,STD,ZN				
12	2075-812	1	COVER FRESH AIR FILTER				
13	7000-339	1	BOX FILTER				
14	2075-978	1	ASSEMBLY HVAC				
15	2045-895	4	LOUVER				
16	2075-793	1	PLENUM OUTLET HVAC				
17	0782-038	1	COMPRESSOR,AC,RC 8985				
18	2075-981	1	ADAPTOR NO.6 90^				
19	2075-980	1	ADAPTOR NO.10 90^				
20	8040-366	4	NUT,HEX,NYLOCK,1/4-20 UNC,ZN				
21	2075-985	1	ASSEMBLY TUBE NO 6 OUTLET				
22	2076-018	1	TUBE ASSY INLET COND				
23	2075-983	1	ASSEMBLY TUBE OUTLET CONDENSOR				
24	2046-250	1	RECEIVER DRIER				
25	8102-128	4	CAPSCREW,HH 5/16-18UNCx7/8 GR8 ZN				
26	8051-242	4	WASHER,SPRING LOCK,5/16,ZN				
27	8050-262	4	WASHER,WROUGHT,5/16,STD,ZN				
28	2075-979	1	ASSEMBLY CONDENSOR				
29	2075-982	1	ASSEMBLY DRIER BRACKET				
30	8102-037	2	CAPSCREW,HH,1/4-20 UNCx.50,GD8				
31	7000-538	1	HOSE AC # 8 48.5"				
32	7000-539	1	HOSE AC # 10 68"				
33	7000-423	1	BELT AC 12" X 33.75"				
34	0090-314	1	SCREW M10 X 50MM GRD. 10.9				
35	0307-790	1	NUT,HEX,JAM,M10x1.5,ZN				
36	0314-512	3	NUT,FLANGE,TOPLock,M10X1.50				
37	0304-131	1	CAPSCREW,HH, M14-1.5 X30MM,GD8				
38	8051-431	1	WASHER,SPRING LOCK,5/8,ZN				
39	7000-996	1	PLATE, BRACKET, A/C, SSL-50/60				
40	0090-552	2	CAPSCREW, M10-1.5 x 35mm				

For kit information, please see page 10-1A

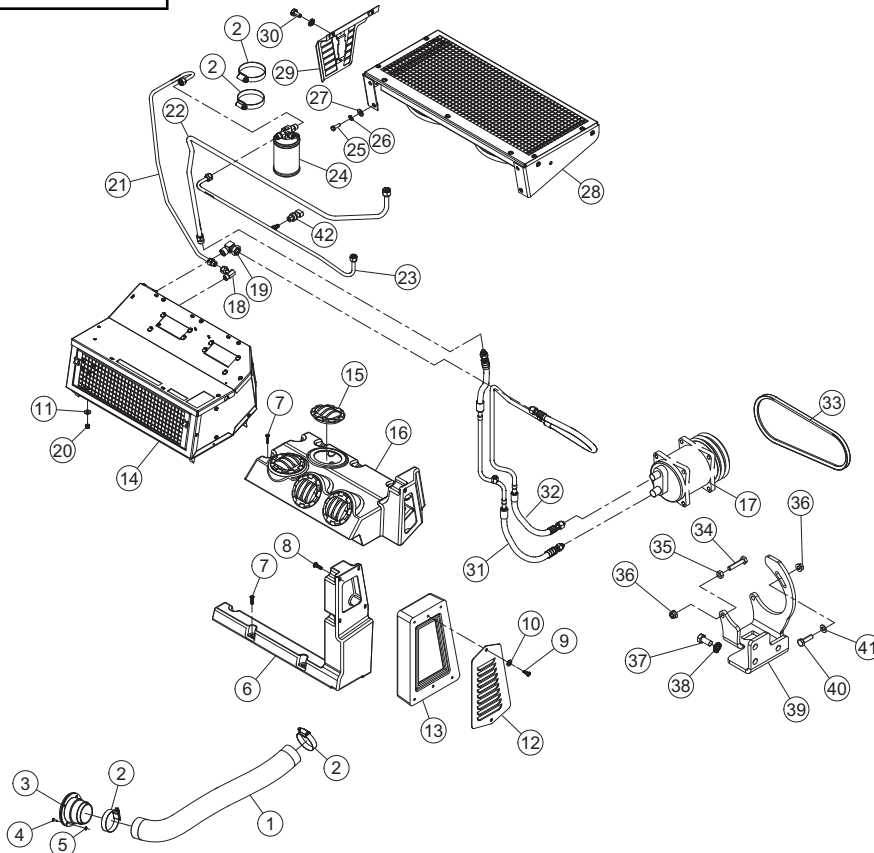

# AIR CONDITIONING / HEATING UNIT

VS-60 Serial # Valid from 00500  
V230S Serial # Valid from 00101

Chapter 7

REF. NO.	PART NUMBER	QTY.	DESCRIPTION	REF. NO.	PART NUMBER	QTY.	DESCRIPTION
1	2076-177	1	PLATE MOUNT LT CONDENSOR				
2	2076-176	1	COVER CONDENSOR OUTLET				
3	2076-178	1	PLATE MOUNT RT CONDENSOR				
4	2076-175	1	CONDENSOR (10.7 X 24.4)				
5	2076-170	2	FAN A/C CONDENSOR				
6	2076-186	1	THERMOSTAT ELECTRONIC RANCO				
7	2045-903	1	BLOWER				
8	2076-182	1	ASSY HEATER CORE				
9	2076-181	1	ASSY EVAPORATOR				
10	2076-172	1	FILTER RECIRC				
11	2076-180	1	COVER RECIRC FILTER				
12	2076-183	2	KNOB THREADED M5 X 20				
13	2076-187	1	VALVE EXPANSION R134a (2 ton)				
14	2076-184	1	ASSEMBLY TUBE NO 10				
15	2076-185	1	ASSEMBLY TUBE NO 6				
16	0090-392	20	SCREW HVAC				
17	2095-543	1	COVER CONDENSOR				
18	0090-369	6	CAPSCREW HH 1/4-20 UNCx.625 GD5 BLK ZN				
19	0090-371	6	WASHER SPRING LOCK 1/4 BLK ZN				
20	0090-372	6	WASHER WROUGHT 1/4 STD BLK ZN				

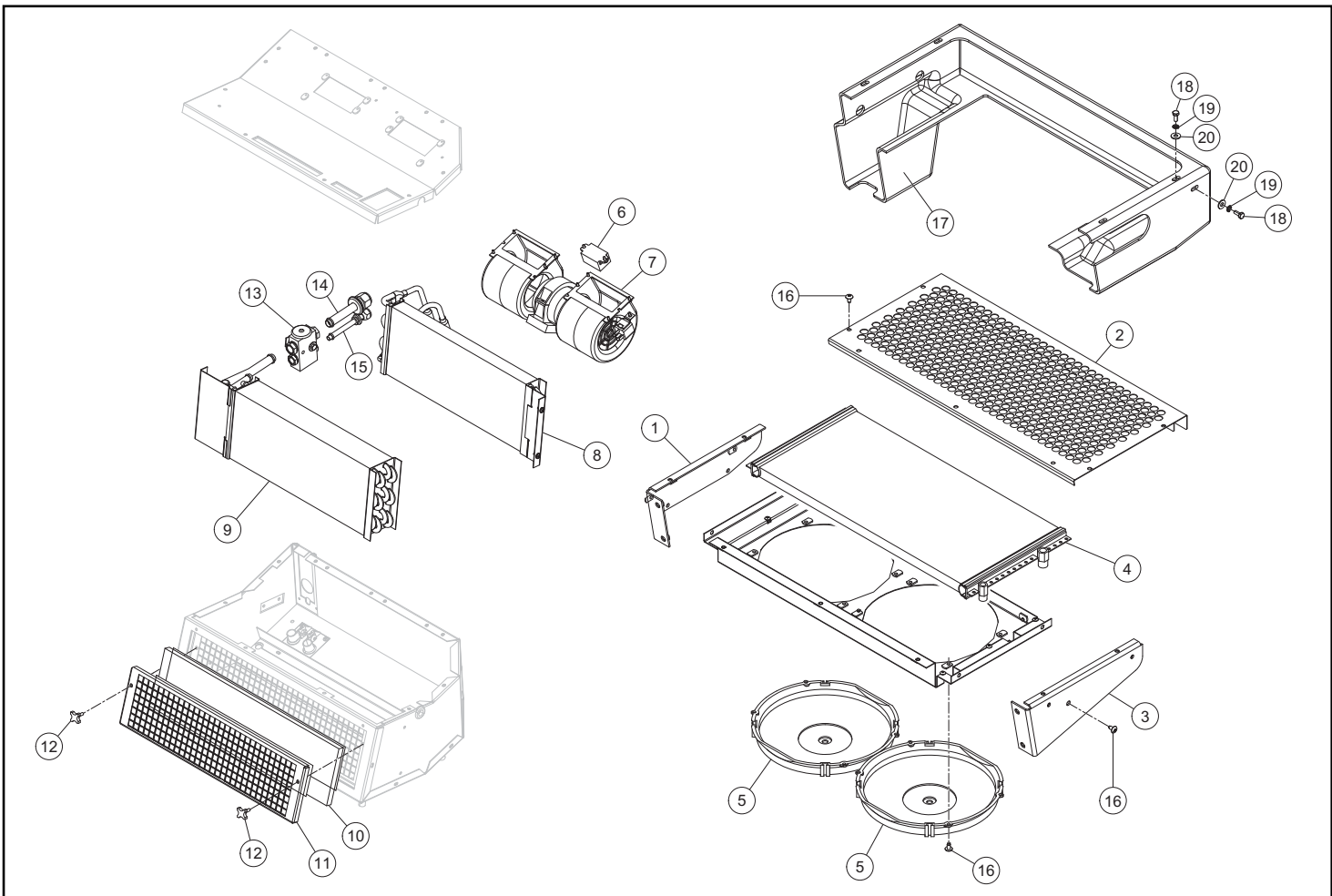

# Chapter 8

## Working Equipment

### **8-1 Quick Attach - Manual**

VS-60 Serial # valid from - 00500 **8-1A**

V230S Serial # valid from - 00101 **8-1A**

### **8-2 Quick Attach - Power**

VS-60 Serial # valid from - 00500 **8-2A**

V230S Serial # valid from - 00101 **8-2A**

**\* Parts manuals are updated on a regular basis. Always refer to current online posted manuals to ensure you have the most up to date information prior to ordering parts.**

**NOTE:** Ordering parts that are painted requires a specific part number format. Please refer to page II of this manual for paint code and ordering information.

# MANUAL QUICK ATTACH

VS-60 Serial # Valid from 00500  
V230S Serial # Valid from 00101

Chapter 8

REF. NO.	PART NUMBER	QTY.	DESCRIPTION	REF. NO.	PART NUMBER	QTY.	DESCRIPTION
1	2045-359	1	WLMT,QUICK-ATTACH,MANUAL				
2	2045-761	1	HANDLE,QA,RH				
3	2045-762	1	HANDLE,QA,LH				
4	2046-405	1	WLMT PIN RH				
5	2046-406	1	WLMT PIN LH				
6	2045-245	2	BLOCK LATCH				
7	8102-418	2	CAPSCREW,HH,1/2-13UNCx 6.0,GD8				
8	0090-002	2	BOLT,SHOULDER,5/8"x.625" GD 8				
9	0090-368	8	WASHER,WROUGHT,1/2,STD,ZN				
10	2015-018	2	WASHER,FENDER,1.75x0.53x0.125				
11	8051-620	6	WASHER,SPRING LOCK,1.0,ZN				
12	0400-621	2	SPOOL,PIVOT				
13	8102-413	2	CAPSCREW,HH,1/2-13 UNCx3.5,GD8,ZN				
14	8040-606	2	NUT,HEX,NYLOCK,1/2-13 UNC,ZN				
15	0400-651	2	SPRING,COMPRESSION				
16	0300-607	2	ZERK,GREASE,1/4-28				

For kit information, please see page 10-1A

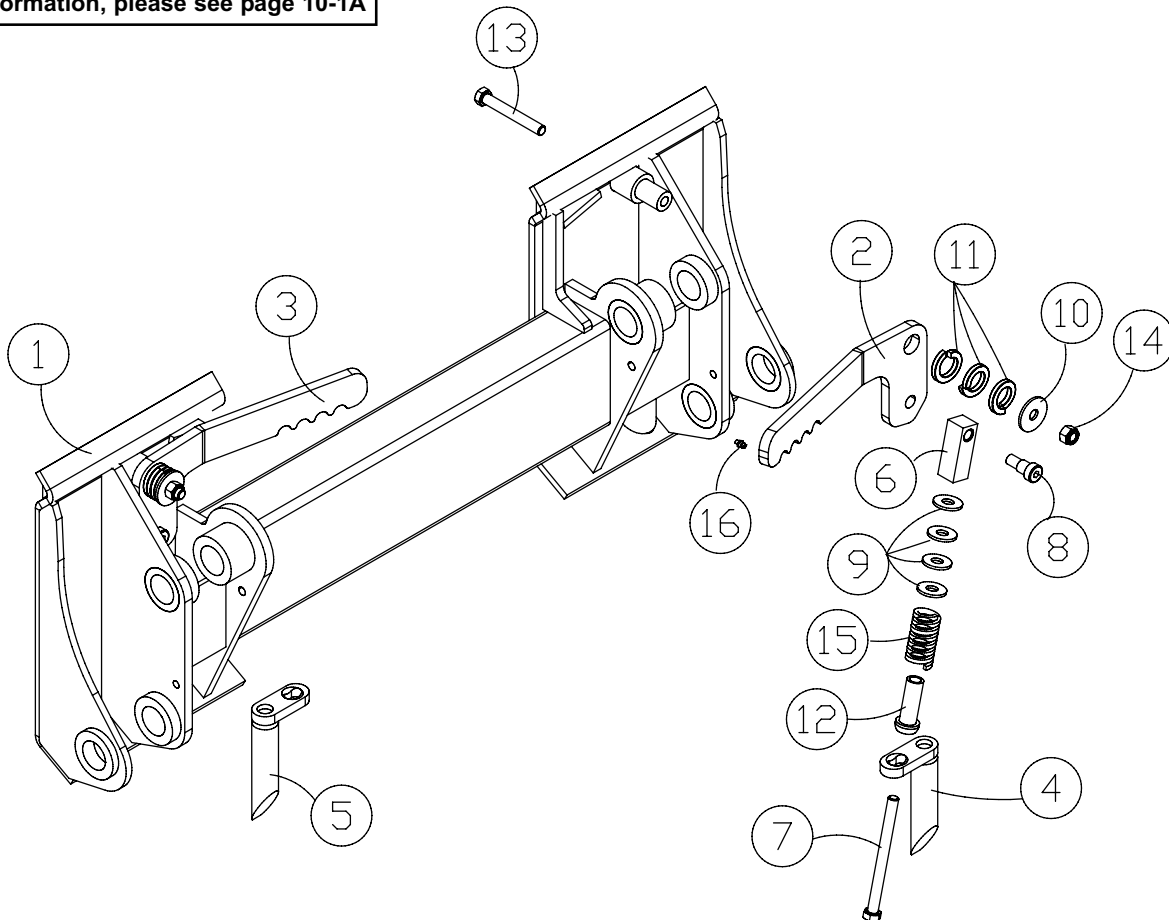

# POWER QUICK ATTACH

VS-60 Serial # Valid from 00500  
V230S Serial # Valid from 00101

Chapter 8

REF. NO.	PART NUMBER	QTY.	DESCRIPTION	REF. NO.	PART NUMBER	QTY.	DESCRIPTION
1	7006-466	1	WLMT, GUARD, QA				
2	2046-316	1	CYLINDER QA LH				
3	2046-317	1	CYLINDER QA RH				
4	2045-235	1	WLMT QUICK-ATTACH HYD				
5	0201-566	1	HOSE, 6M4K-6FFORX90S-6FFORX-49.				
6	0201-545	1	HOSE, 6M4K-6FFORX-6FFORX90S-14.				
7	0201-565	1	HOSE, 6M4K-6FFORX90S-6FFORX-53.				
8	0201-544	1	HOSE, 6M4K-6FFORX-6FFORX90S-25.				
9	0310-328	2	ADAPTER, 6MFFOR-6MB-90				
10	0201-542	2	ADAPTER, TEE, 6FS-6FS-6NWO				
11	8102-412	2	CAPSCREW, HH, 1/2-13UNCx3.25 GD8				
12	8102-686	1	CAPSCREW, HH, 3/4-10UNCx4.25 GD8				
13	8040-786	1	NUT, HEX, NYLOCK, 3/4-10 UNC, ZN				
14	2045-245	2	BLOCK LATCH				
15	2045-246	2	LATCH QA				
16	0090-001	2	BOLT, SHOULDER, 5/8"x1.25" GD 8				
17	8040-606	2	NUT, HEX, NYLOCK, 1/2-13 UNC, ZN				
18	0090-368	8	WASHER, WROUGHT, 1/2, STD, ZN				
19	0300-607	2	ZERK, GREASE, 1/4-28				
20	0400-651	2	SPRING, COMPRESSION PLATED				
21	0400-621	2	SPOOL, PIVOT				
22	2046-405	1	WLMT PIN LH				
23	2046-406	1	WLMT PIN RH				
24	8102-418	2	CAPSCREW, HH, 1/2-13UNCx 6.0, GD8				
25	0310-733	1	INSERT, CLAMP, TWIN 75" T3075-PP				
26	0310-828	1	COVER, CLAMP, 3/4" TCP-T3				
27	8102-136	1	CAPSCREW, HH, 5/16-18x1.75 ZN GD				

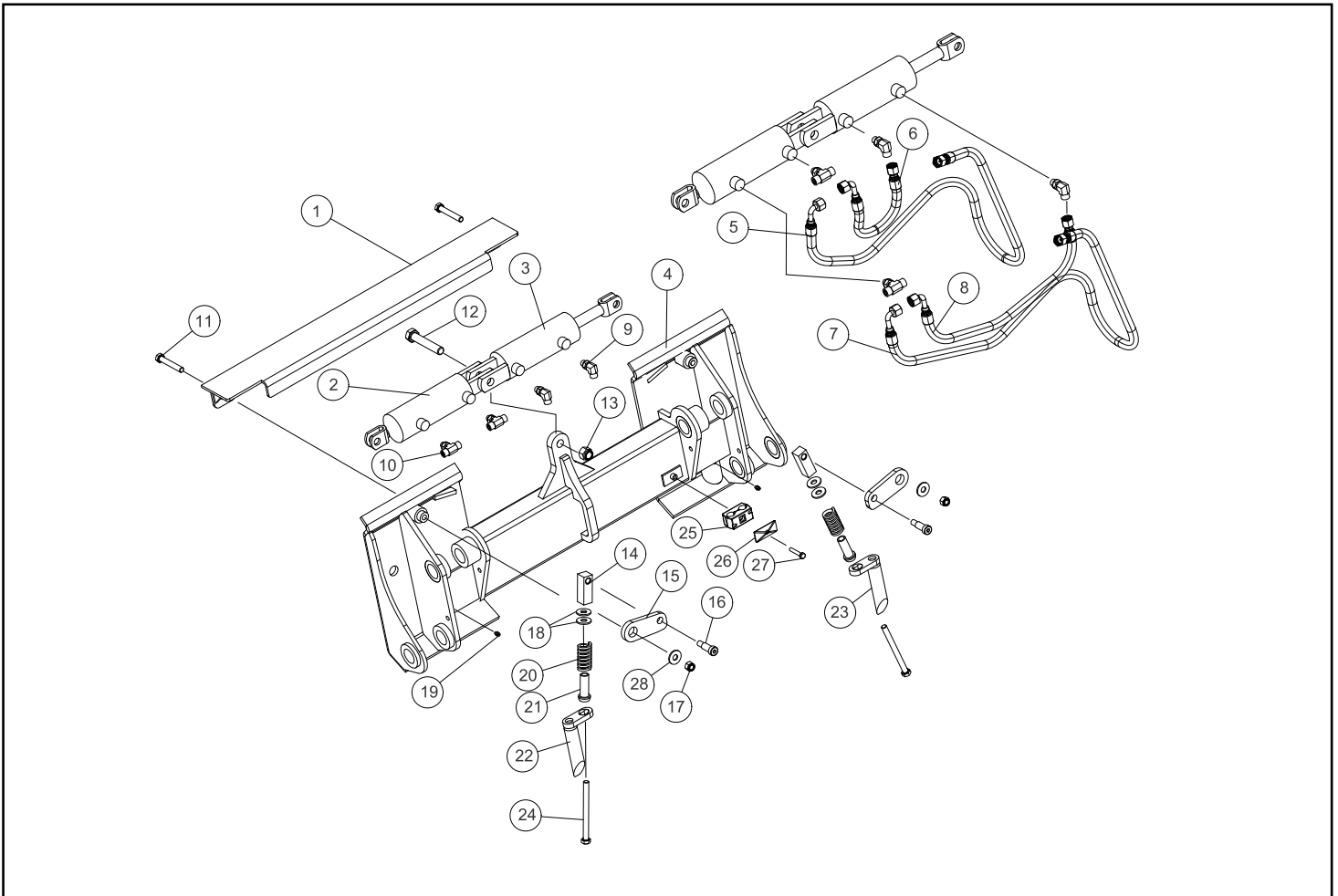

# Chapter 9

## Graphics / Safety Decals

### **9-1 Safety Decals (ANSI)**

VS-60 Serial # valid from - 00500 **9-1A**

V203S Serial # valid from - 00101 **9-1A**

### **9-2 Safety Decals (ISO)**

VS-60 Serial # valid from - 00500 **9-2A**

V230S Serial # valid from - 00101 **9-2A**

### **9-3 ASV Graphics**

VS-60 Serial # valid from - 00500 **9-3A**

### **9-4 TEREX Graphics**

V230S Serial # valid from - 00101 **9-4A**

**\* Parts manuals are updated on a regular basis. Always refer to current online posted manuals to ensure you have the most up to date information prior to ordering parts.**

# SAFETY DECALS-US (ANSI)

VS-60 Serial # Valid from 00500  
V230S Serial # Valid from 00101

Chapter 9

REF. NO.	PART NUMBER	QTY.	DESCRIPTION	REF. NO.	PART NUMBER	QTY.	DESCRIPTION
1	2046-299	1	DECAL ANSI O&M FALL FIRE HAZARD				
2	0310-197	4	DECAL,TIE DOWN 156-5762				
3	2030-592	2	DECAL ANSI LOADER CRUSH HAZARD				
4	2030-602	2	DECAL ANSI SKIN INJECTION HAZARD				
5	7005-813	2	DECAL ANSI RUN OVER SSL				
6	2030-594	2	DECAL ANSI LIFT ARM BRACE				
7	2030-601	1	DECAL ANSI HOT SURFACES HAZARD				
8	2030-595	1	DECAL ANSI RADIATOR HAZARD				
9	2030-600	1	DECAL ANSI BELT FAN HAZARD				
10	4046-078	1	DECAL DIESEL FUEL ONLY				
11	4046-079	1	DECAL HYDRAULIC OIL ONLY				
12	2030-603	1	DECAL ANSI BATTERY EXPLOSION HAZARD				
13	7005-812	2	DECAL ANSI PINCH POINT VERTICAL SSL				
14	0304-320	1	DECAL,OWNER'S MANUAL				
15	7005-825	1	DECAL WARNING CAB MULTI -RT				
16	2030-597	1	DECAL ANSI FALL HAZARD (3 POINT ENTRY)				
17	2046-149	1	DECAL DRIVE CONTROL (ONE SPEED MACHINES ONLY)				
18	7001-231	1	DECAL DRIVE CONTROL (TWO SPEED MACHINES ONLY)				
19	7001-232	1	DECAL LIFT ARM CONTROL SSL				
20	7011-205	1	DECAL ANSI DANGER- FUELING				
21	2046-049	1	DECAL EMERGENCY EXIT				
22	0404-594	2	DECAL - NOT A LIFT POINT				

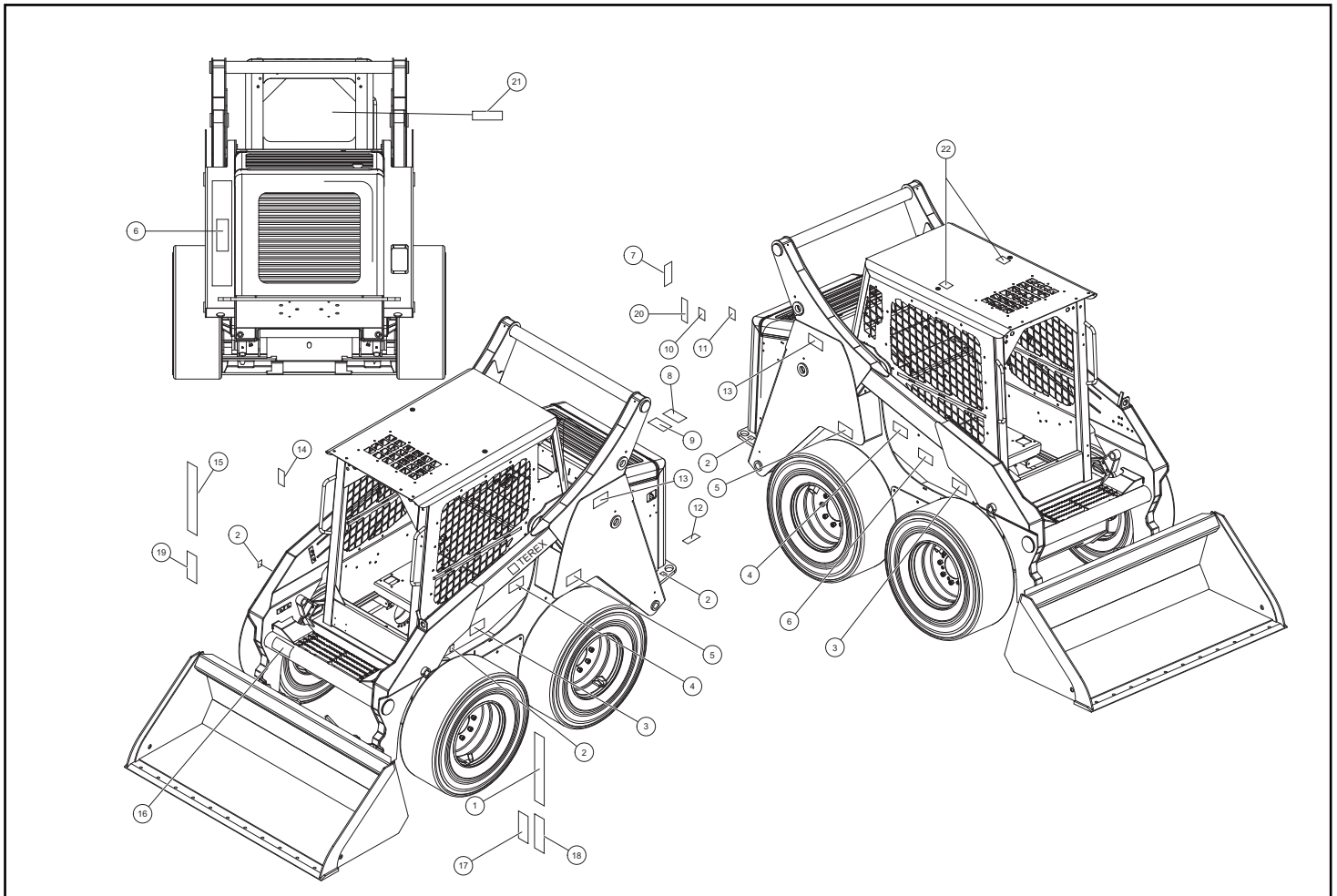

# SAFETY DECALS-ROW (ISO)

VS-60 Serial # Valid from 00500  
V230S Serial # Valid from 00101

Chapter 9

REF. NO.	PART NUMBER	QTY.	DESCRIPTION	REF. NO.	PART NUMBER	QTY.	DESCRIPTION
1	2046-146	1	DECAL ISO O&M FALL FIRE HAZARD				
2	0310-197	4	DECAL,TIE DOWN 156-5762				
3	2030-415	2	DECAL ISO LOADER CRUSH HAZARD				
4	2030-553	2	DECAL ISO SKIN INJECTION HAZARD				
5	7006-203	2	DECAL ISO RUN OVER SSL				
6	2030-417	2	DECAL ISO LIFT ARM BRACE				
7	2030-552	1	DECAL ISO HOT SURFACES HAZARD				
8	2030-418	1	DECAL ISO RADIATOR HAZARD				
9	2030-551	1	DECAL ISO BELT FAN HAZARD				
10	4046-078	1	DECAL DIESEL FUEL ONLY				
11	4046-079	1	DECAL HYDRAULIC OIL ONLY				
12	2030-565	1	DECAL ISO BATTERY EXPLOSION HAZARD				
13	7006-204	2	DECAL ISO PINCH POINT VERTICAL SSL				
14	0304-320	1	DECAL,OWNER'S MANUAL				
15	7006-202	1	DECAL WARNING CAB MULTI -RT				
16	2030-425	1	DECAL ISO FALL HAZARD (3 POINT ENTRY)				
17	2046-149	1	DECAL DRIVE CONTROL (ONE SPEED MACHINES ONLY)				
18	7001-231	1	DECAL DRIVE CONTROL (TWO SPEED MACHINES ONLY)				
19	7001-232	1	DECAL LIFT ARM CONTROL SSL				
20	0404-543	1	DECAL ISO ULSD FUEL HANDLING PRECAUTIONS				

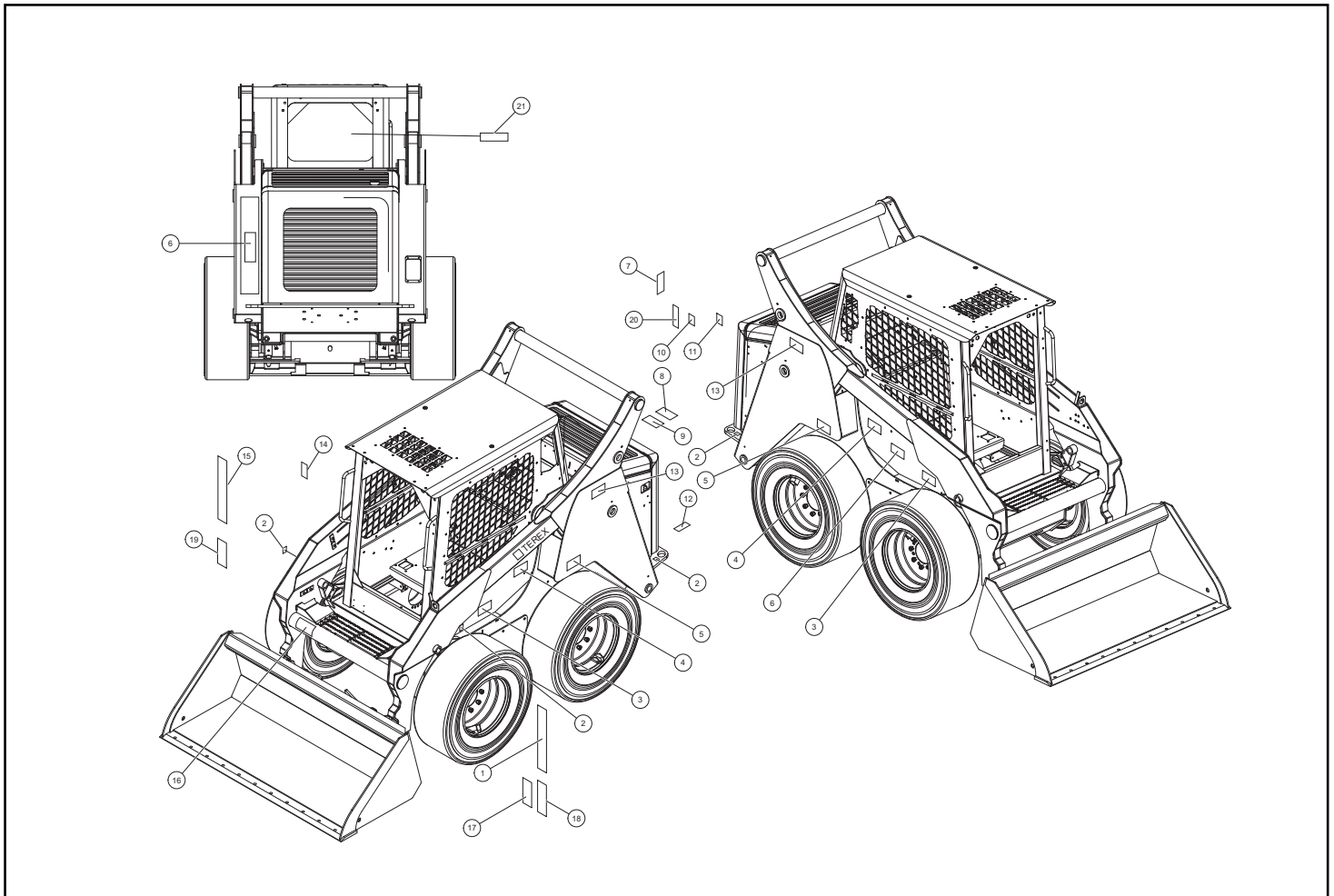

REF. NO.	PART NUMBER	QTY.	DESCRIPTION	REF. NO.	PART NUMBER	QTY.	DESCRIPTION
1	2030-333	2	DECAL ASV				
2	7001-478	1	DECAL, VS-60 RH REAR				
3	7001-476	1	DECAL, VS-60 RH FRONT				
4	2010-161	1	DECAL TOWER ASV				
5	7001-475	1	DECAL, VS-60 LH FRONT				
6	7001-477	1	DECAL, VS-60 LH REAR				
7	2052-422	1	DECAL ASV 8 1/2" LONG				

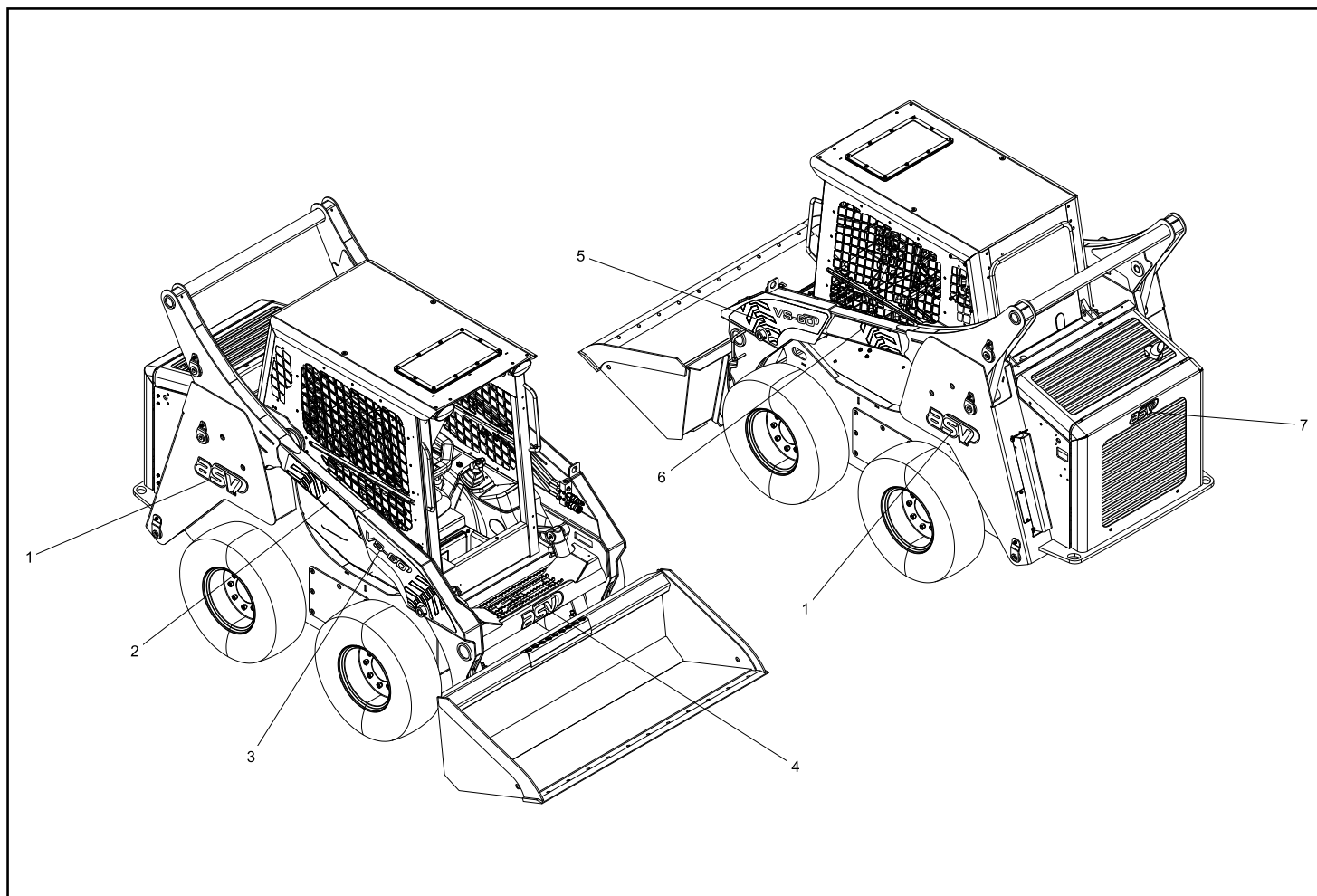

REF. NO.	PART NUMBER	QTY.	DESCRIPTION
1	7000-586	1	DECAL TEREX 16" x 3.75"
2	2075-965	3	DECAL LOADER LEFT/RIGHT REAR
3	7000-545	1	DECAL CHASSIS RH REAR
4	0090-597	2	DECAL V230S
5	7000-546	1	DECAL CHASSIS LH REAR
6	0090-615	2	DECAL GEN 2 BLACK

REF. NO.	PART NUMBER	QTY.	DESCRIPTION

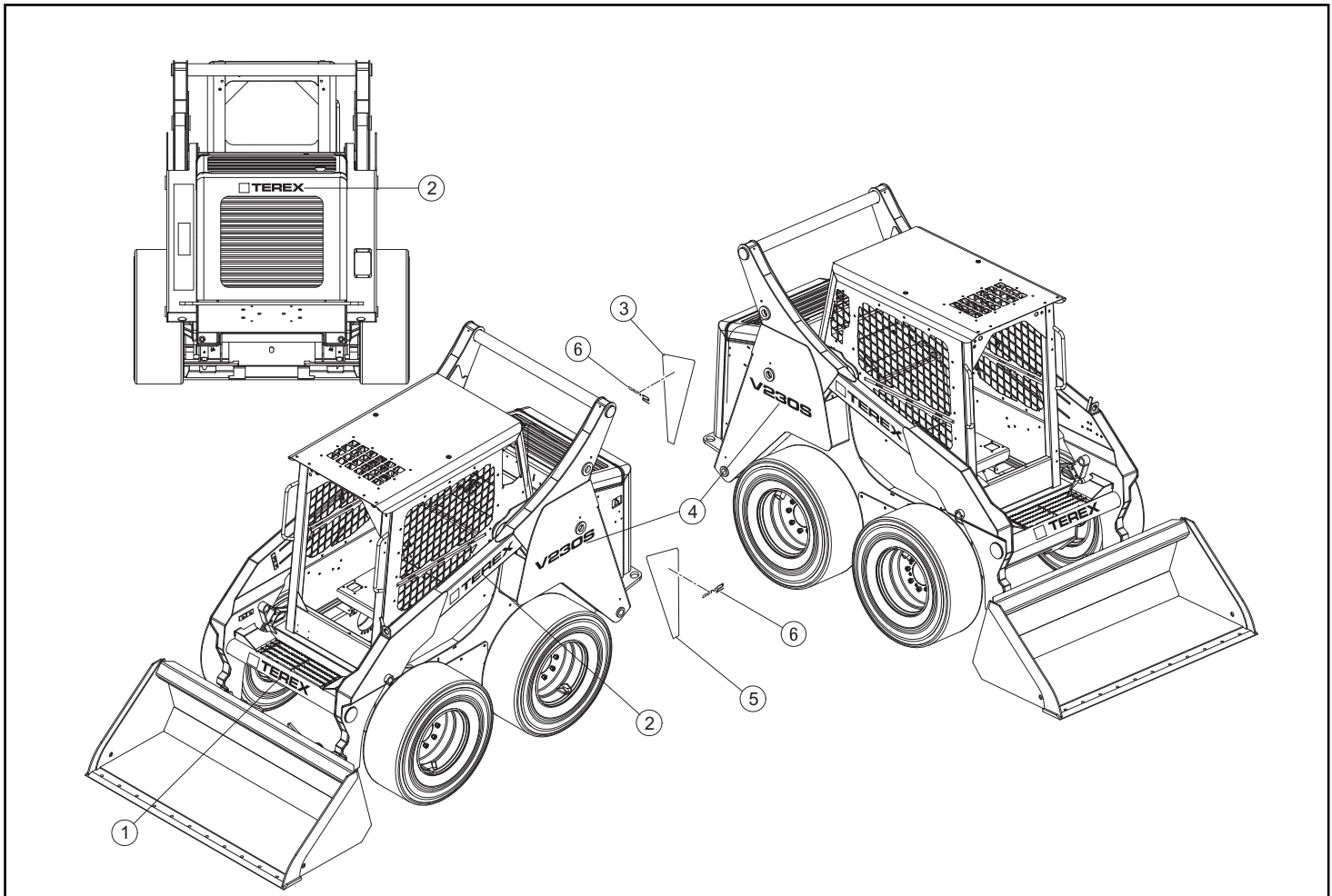

## Kits

<u>Page</u>	<u>Kit</u>	<u>Part number</u>
2-1A	Power disconnect switch kit Block heater field install kit	7001-358 0304-549
2-2A	Door prop latch assembly includes items items 44-51	7001-370
3-2A	Complete valve seal kit	7000-622
3-6A	Complete seal kit for item 5	7001-486
3-7A	Complete seal kit for item 71	7001-488
7-3A	Radio field install Kit	2076-268
7-4A	Window latch slider kit STD. Door field install kit Window field install kit	0404-165 7000-712 7000-714
7-5A	Complete wiper kit	7000-770
7-6A	Heater field install kit	7000-716
7-7A	AC/Heater field install kit	7000-715
8-1A	Manual QA assembly Upgrade to hydraulic QA kit	0404-034 7000-877



**ASV Holdings Inc.**

**840 Lily Lane**

**Grand Rapids MN. 55744**

**1-800-205-9913**

**[www.asvi.com](http://www.asvi.com)**