

Master Part Manual

Compact Track Loader

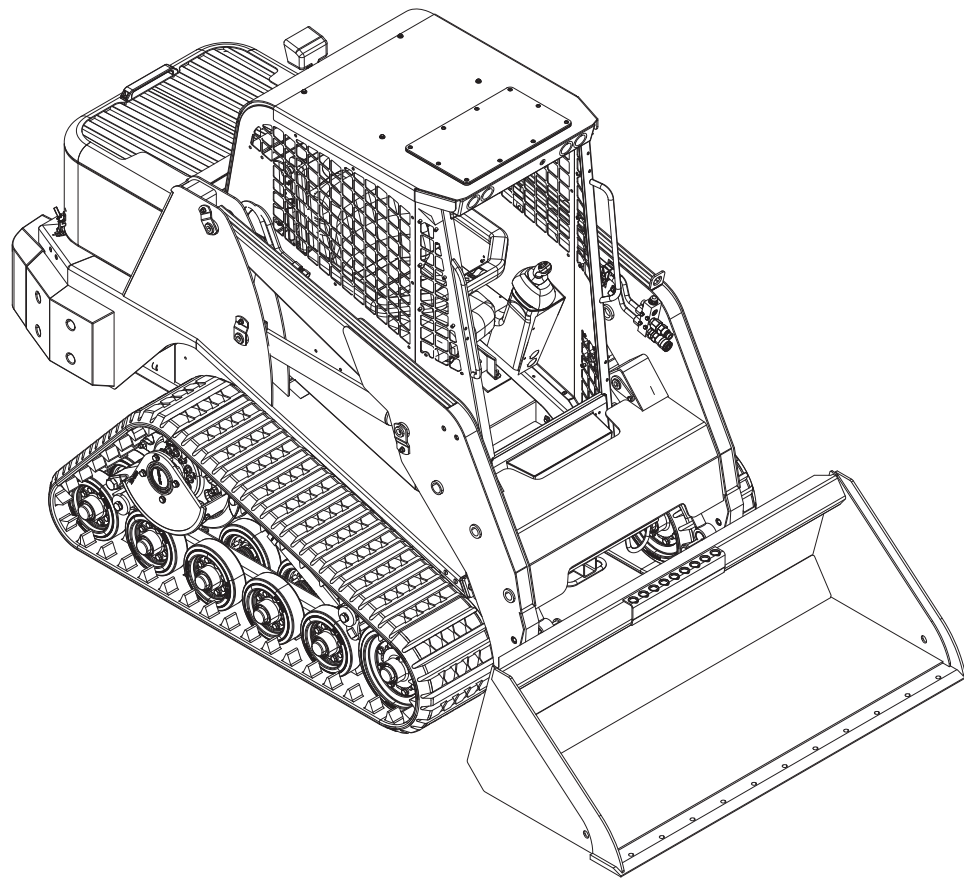

RT-60
R190T

Printed 6/20

Table of Contents

1. **Service Parts**
 - 1-1 General Service Items / Lubricants
 - 1-2 Cylinder Service Items
 - 1-3 Harnesses
2. **Fuel/Engine**
 - 2-1 Diesel Engine
 - 2-2 Cooling System
3. **Hydraulic Components**
 - 3-1 Hydraulic Reservoir
 - 3-2 Lift Arm Assembly
 - 3-3 Lift Arm Tubes and Fittings
 - 3-4 Hydraulic Control
 - 3-5 Drive Auxilliary Pump
4. **Electrical**
 - 4-1 Light Bar Assembly
 - 4-2 Fuse Panel
5. **Undercarriage**
 - 5-1 Torsion Axle
 - 5-2 Undercarriage Assembly, RT
 - 5-3 Undercarriage Assembly, LT
 - 5-4 Track Installation Tool
6. **Mainframe**
 - 6-1 Chassis
 - 6-2 Hood Assembly
7. **Cab / Heating / Air Conditioning**
 - 7-1 Cab
 - 7-2 Enclosed Cab
 - 7-3 Cab Heat
 - 7-4 Cab Heat / Air Conditioning
8. **Quick Attach**
 - 8-1 Quick Attach- Manual
 - 8-2 Quick Attach- Hydraulic
9. **Graphics / Safety Decals**
 - 9-1 ANSI Safety Decals
 - 9-2 ISO Safety Decals
 - 9-3 Machine Graphics (ASV)
 - 9-4 Machine Graphics (Terex)
10. **Kits**
 - 10-1 Kits

* “Valid from” includes machines produced (from the indicated serial number) until the date this manual was printed. See manual cover for print date.

Parts manuals are updated regularly. To ensure current information, always refer to the latest version of this manual (posted online, consult your dealer).

NOTE: Ordering parts that are painted requires a specific part number format. Please refer to page II of this manual for paint code and ordering information.

Painted Service Parts

ordering guidelines

Compact Track and Skid Steer Loaders are available in various colors and nomenclatures (brands / model names). **Paint color needs to be specified when ordering painted components.** When ordering painted components, inform the support representative of the brand and model name of your machine before selecting the proper color from the list below. The support representative should be able to assist you in finding the correct one based on your machine's **VIN number**. This should help to identify the original machine configuration and nomenclature.

***Note: Not all colors are available on all components. Available colors are limited to those considered "standard" on your particular machine and component(s). Please do not attempt to order non-standard colors for your machine as the order will not be fulfilled until corrected.**

The color codes are to be referenced as a suffix to the part number of the component you are requesting, for example: 0000-000-GRN (indicating a green part).

The following is a list of available colors.

<u>Color</u>	<u>Color Code:</u>
BLACK	BLK (ALL MODELS)
WHITE	WHT (TEREX)
YELLOW	YEL (VERMEER)
YELLOW	YEY (ASV)
GREEN	GRN (SUNBELT)
RED	RED (TAKEUCHI)
GRAY	GRY (TEE)
GRAY	GTG (SKID STEER WHEELS ONLY)
ORANGE	ORN (ASPLUNDH)

Chapter 1

Service Parts

<u>1-1 General Service Items / Lubricants.....</u>	1-1A
<u>1-2 Cylinder Service Items</u>	1-2A
<u>1-3 Harnesses</u>	1-3A

- * Parts manuals are updated on a regular basis. Always refer to the current online version to ensure you have the most up to date information prior to ordering parts.

GENERAL SERVICE ITEMS & LUBRICANTS

<u>ITEM</u>	<u>MANUFACTURER/DESCRIPTION</u>	<u>PART NUMBER</u>
-Engine Oil Filter	Filter- Oil	0200-377
-Primary Air Filter	Filter- Air	0200-339
-Secondary Air Filter	Filter- Air	0200-340
-Engine Fuel Filter	Filter- Fuel	0200-213
-Fuel screen	Screen	0200-561
-Water Separator O-ring		0201-985
-Fan Belt (qty: 2 without A/C, 1 with A/C)	Gates	2030-632
-A/C Belt (qty: 1 with A/C)	Gates (A48K)	0201-645
250 Hour Service Kit	Kit, 250 hr	0404-860
500 Hour Service Kit	Kit, 500 hr	0404-861

HYDRAULIC SERVICE ITEMS & LUBRICANTS

<u>ITEM</u>	<u>DESCRIPTION</u>	<u>PART NUMBER</u>
-Hydraulic Oil Filter	Filter- Hydraulic oil	0200-204
-Kit,Seal,Loader Valve & Relief	Fits Loader Valve (P/N:2030-817)	2010-877

<u>O-RING</u>	<u>PART NUMBER</u>
# 4, ORB Type	0314-366
# 6, ORB Type	0310-619
# 8, ORB Type	0307-353
# 10, ORB Type	0310-620
# 12, ORB Type	0310-621
# 16, ORB Type	0307-354
# 20, ORB Type	0310-832

CYLINDER SERVICE ITEMS

RT-60 Serial #: valid from - 00600

R190T Serial #: valid from - 00300

- RH-Bucket/Tilt P/N: 2030-804
- LH-Q/A P/N: 2046-316
- LH-Bucket/Tilt P/N: 2030-803
- RH-Q/AP/N: 2046-317
- Lift-Arm P/N: 2030-824

<u>ITEM</u>	<u>MANUFACTURER/DESCRIPTION</u>	<u>PART NUMBER</u>
-Kit,Seal,Bucket/Tilt Cylinder	Fits Cylinder (P/N:2030-803/804)	0404-535
-Rod,Bucket/Tilt Cylinder	Fits Cylinder (P/N:2030-803/804)	2030-660
-End Gland,Bucket/Tilt Cylinder	Fits Cylinder (P/N:2030-803/804)	2030-834
-Nut,Bucket/Tilt Cylinder	Fits Cylinder (P/N:2030-803/804)	2030-656
-Kit,Seal,Lift Arm Cylinder	Fits Cylinder (P/N:2030-824)	0404-534
-End Gland,Lift Arm Cylinder	Fits Cylinder (P/N:2030-824)	2030-838
-Rod,Lift Arm Cylinder	Fits Cylinder (P/N:2030-824)	2030-659
-Nut,Lift Arm Cylinder	Fits Cylinder (P/N:2030-824)	2030-656
-Kit,Seal,Q/A Cylinder	Fits Cylinder (P/N:2046-316/317)	2076-292

HARNESSES RT-50/R160T

RT-60 Serial # 00600-00667
R190T Serial # 00300-00511

<u>ITEM</u>	<u>PART NUMBER</u>
HARNESS,JUMPER	0200-200
HARNESS,WIPER,A W/LO	0304-572
HARNESS,WIPER,B	0304-573
HARNESS,JUMPER,QA	2015-042
HARNESS GAUGE 2 UNIT	2030-275
MODULE CAPACITOR/RESISTOR	2076-296
HARNESS GAUGE 4 UNIT	2030-929
HARNESS AUX PWR ACT	2010-689
HARNESS MAIN PT50/60	2030-760
HARNESS CAB PT50/60	2030-761

RT-60 Serial # 00668-04102
R190T Serial # 00512-04102

<u>ITEM</u>	<u>PART NUMBER</u>
HARNESS,JUMPER	0200-200
HARNESS,WIPER,A W/LO	0304-572
HARNESS,WIPER,B	0304-573
HARNESS,JUMPER,QA	2015-042
HARNESS GAUGE 2 UNIT	2030-275
MODULE CAPACITOR/RESISTOR	2076-296
HARNESS GAUGE 3 UNIT BEEDE CTL	2030-969
HARNESS AUX PWR ACT	2010-689
HARNESS MAIN PT50/60	2030-760
HARNESS CAB PT50/60	2030-761

RT-60 Serial # valid from: 04103
R190T Serial # valid from: 04103

<u>ITEM</u>	<u>PART NUMBER</u>
HARNESS,JUMPER	0200-200
HARNESS,WIPER,A W/LO	0304-572
HARNESS,WIPER,B	0304-573
HARNESS,JUMPER,QA	2015-042
HARNESS, GAUGE 3 UNIT CTL	2030-987
MODULE CAPACITOR/RESISTOR	2076-296
HARNESS, GAUGE JUMPER	7011-233
HARNESS AUX PWR ACT	2010-689
HARNESS MAIN PT50/60	2030-760
HARNESS CAB PT50/60	2030-761

Chapter 2

Engine / Radiator

2-1 Fuel Tank

RT-60 Serial # valid from - 00600.2-1A

R190T Serial # valid from - 00300.2-1A

2-1 Engine

RT-60 Serial # valid from - 00600.2-2A

R190T Serial # valid from - 00300.2-2A

2-2 Radiator / Oil Cooler

RT-60 Serial # valid from - 00600.2-3A

R190T Serial # valid from - 00300.2-3A

- * **Parts manuals are updated on a regular basis. Always refer to the current online version to ensure you have the most up to date information prior to ordering parts.**

NOTE: Ordering parts that are painted requires a specific part number format. Please refer to page II of this manual for paint code and ordering information.

FUEL TANK

RT- 60 valid from - 00600
R190T valid from - 00300

Chapter 2

REF. NO.	PART NUMBER	QTY.	DESCRIPTION	REF. NO.	PART NUMBER	QTY.	DESCRIPTION
1	2030-376	1	WLMT,TANK,FUEL				
2	0200-217	1	MAT,FLOOR				
3	4030-131	1	PLATE FILLER FLOOR				
4	0304-045	1	SEAT (SEE NOTE)				
5	0304-662	1	HARNES, SWITCH,SEAT				
6	2010-127	1	SWITCH,SEAT				
7	2010-434	1	MOUNT SEAT FRONT				
8	8102-130	4	CAPSCREW,HH 5/16-18x3/4,GR8				
9	8040-486	4	NUT,HEX,NYLOCK,3/8-16 UNC,ZN				
10	8040-606	2	NUT,HEX,NYLOCK,1/2-13 UNC,ZN				
11	0304-206	1	WLMT,MNT,SEAT,REAR PAINTED BLACK				
12	8102-404	2	CAPSCREW,HH 1/2-13UNCx1.25 GD8 ZN				
13	2076-409	1	BELT SEAT 2" ADJUSTABLE				
14	0315-100	6	CLAMP,HOSE,#4 MM4				
15	0200-361	1	HOSE,FUEL,3/16IDx35"				
16	0200-353	1	HOSE,FUEL,5/16IDx30"				
17	0304-509	1	HOSE,FUEL,5/16x22"				
18	2030-961	1	ASSY SENDING UNIT				
19	0304-157	6	SCREW,ORING				
20	0090-676	1	WASHER, FLAT - 10-24 BRASS				
21	8051-152	1	WASHER,SPRING LOCK,#10,ZN				
22	0090-674	1	NUT, HEX - 10-24 BRASS				
23	0304-447	1	HOSE,7/16X5/16POLY,1.30FT				
24	0301-375	1	WEIGHT,IN-TANK				
25	0304-617	1	GASKET,TANK,FUEL				
26	0303-096	2	CLAMP,HOSE,2.0",HI-TORQUE				
27	0304-037	1	HOSE,FILL,DIESEL,FUEL				
28	8051-272	2	WASHER,SPRING LOCK,3/8,ZN				
29	8050-262	4	WASHER,WROUGHT,5/16,STD,ZN				
30	8102-222	2	CAPSCREW,HH,3/8-16 UNCx1.0.GD8,ZN				

**NOTE: Optional Suspension Seat
Part Number- 2030-743**

**NOTE: Item 3 (on a/c
equipped machines)
is P/N: 4030-010**

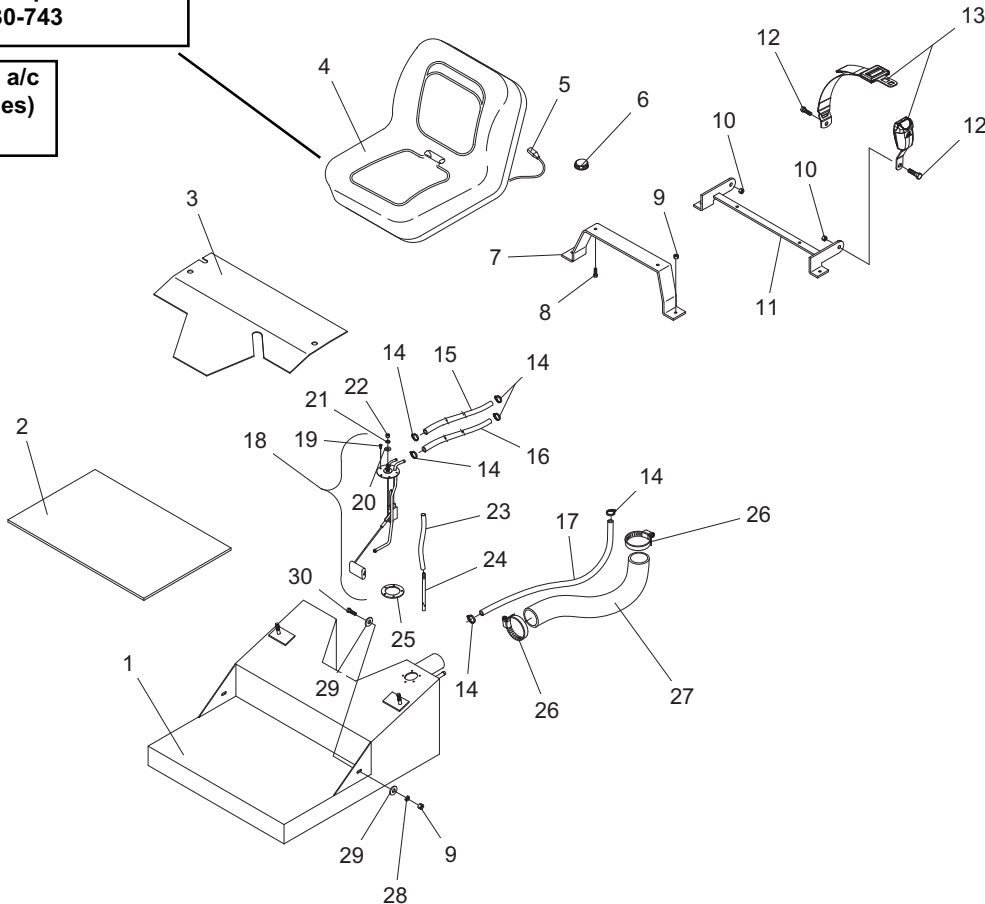

ENGINE

RT- 60 valid from - 00600
R190T valid from - 00300

Chapter 2

REF. NO.	PART NUMBER	QTY.	DESCRIPTION
1	8040-726	4	NUT,HEX,NYLOCK,5/8-11 UNC,ZN
2	0090-613	4	WASHER, 2.5" OD X .64" ID X .179
3	2011-082	4	ISOLATOR, ENGINE, 45 DURO
4	0303-238	2	CLAMP,HOSE
5	0200-495	1	HOSE,INTAKE,3024cT
6	0200-157	1	ASSY,CLEANER,AIR
7	8102-598	4	CAPSCREW,HH,5/8-11UNCx3.25,GD8
8	0200-165	1	WLMT,MNT,ENGINE,RH
9	0304-900	1	MNT,PLATE,PUMP
10	0304-507	1	PLATE,FLYWHEEL
11	2031-051	1	ENGINE PERKINS SERVICE REPLACEMENT
12	0200-166	1	WLMT,MNT,ENGINE,LH
13	0200-562	1	STARTER (PERKINS #185086600)
14	0304-503	1	VALVE,DUST
15	0200-339	1	FILTER,AIR,PRIMARY
16	0200-340	1	FILTER,AIR,SECONDARY
17	0200-158	1	BAND,MNT,AIR CLEANER
18	0200-329	5	CAPSCREW,HH,M8x1.25x16MM
19	8051-242	17	WASHER,SPRING LOCK,5/16,ZN
20	2030-883	1	MNT,ENGINE,REAR,RH
21	8040-426	2	NUT,HEX,NYLOCK,5/16-18 UNC,ZN
22	8102-130	7	CAPSCREW,HH 5/16-18x3/4,GR8
23	8050-247	2	WASHER,WROUGHT,5/16,SAE,ZN
24	0300-211	4	CAPSCREW,M8 x 1.25 x 25MM LG
25	0304-511	1	GASKET,MUFFLER
26	2030-149	1	PIPE,EXHAUST,MUFFLER END
27	0300-263	1	CLAMP,MUFFLER,2"
28	0200-122	1	MUFFLER RT60
29	2030-632	1	BELT FAN
30	8040-246	2	NUT,HEX,NYLOCK,10-24 UNC,ZN
31	0304-078	1	LEVER,THROTTLE
32	8105-429	2	CAPSCREW,SOC HD,10-24X5/8,BLZN
33	0304-839	8	WASHER,SPRING LOCK,14MM
34	0200-691	1	STRAP,HOLD-DOWN,BATTERY
35	0200-338	1	ASSY,FILTER,WATER
36	2051-439	1	BATTERY,50 SERIES
37	0301-083	2	PROTECTOR,POST,BATTERY
38	2030-433	1	WLMT,MNT,ENGINE,LH,REAR
39	0403-641	2	CLEVIS (THROTTLE CABLE)
40	0300-581	1	W/NUTS,U-BOLT,1/4-20

REF. NO.	PART NUMBER	QTY.	DESCRIPTION
41	0304-835	1	BULB,PRIMER
42	0300-455	1	CABLE,THROTTLE
43	4046-090	1	CABLE BATTERY GROUND
44	2030-588	1	CABLE,BATTERY,POSITIVE
45	0304-131	8	CAPSCREW,HH, M14-1.5 X30MM,GD8
46	0200-178	1	WLMT,BRKT,MNT,FILTER
47	0200-377	1	FILTER,OIL,ENGINE (PERKINS #140517050)
48	0300-732	4	CLAMP,HOSE,#4
49	0304-509	1	HOSE,FUEL,5/16x26"
50	0304-510	1	HOSE,FUEL,5/16x34"
51	0200-215	1	ASSY,FILTER,FUEL,PERKINS,404C22
52	0200-213	1	FILTER,FUEL,PERKINS,404C22
53	8102-220	2	CAPSCREW,HH,3/8-16x0.75",GD8
54	0310-501	1	GUARD,BATTERY
55	8040-486	2	NUT,HEX,NYLOCK,3/8-16 UNC,ZN
56	8102-132	8	CAPSCREW,HH,5/16-18UNCx1.0 GD8
57	0300-546	1	CABLE,GROUND,ENGINE
58	0200-159	1	BRKT,MNT,AIR CLEANER
59	8051-272	21	WASHER,SPRING LOCK,3/8,ZN
60	8102-222	20	CAPSCREW,HH,3/8-16 UNCx1.0,GD8
61	8102-138	1	CAPSCREW,HH,5/16-18 X 2.25 GD8
62	2055-190	1	HOSE,BREATHER,5/16,6"
63	0200-335	6	SPRING,TAIPIPE
64	0200-333	1	TAILPIPE,CENTER
65	2030-148	1	PIPE,EXHAUST,FLANGE END
66	2030-100	1	ASSY,PIPE,EXHAUST,3024cT
67	0304-549	1	HEATER,BLOCK
68	0200-560	1	CAP,AIR CLEANER
69	0200-617	1	SCREEN,FILTER,WATER
70	0200-313	1	INDICATOR,AIRCLEANER
71	2030-279	1	GUARD,RAIN, STARTER
72	0403-642	2	PIN CLIP
73	0090-561	1	CAPSCREW M14-1.5 X 25MM DIN 961 CLASS

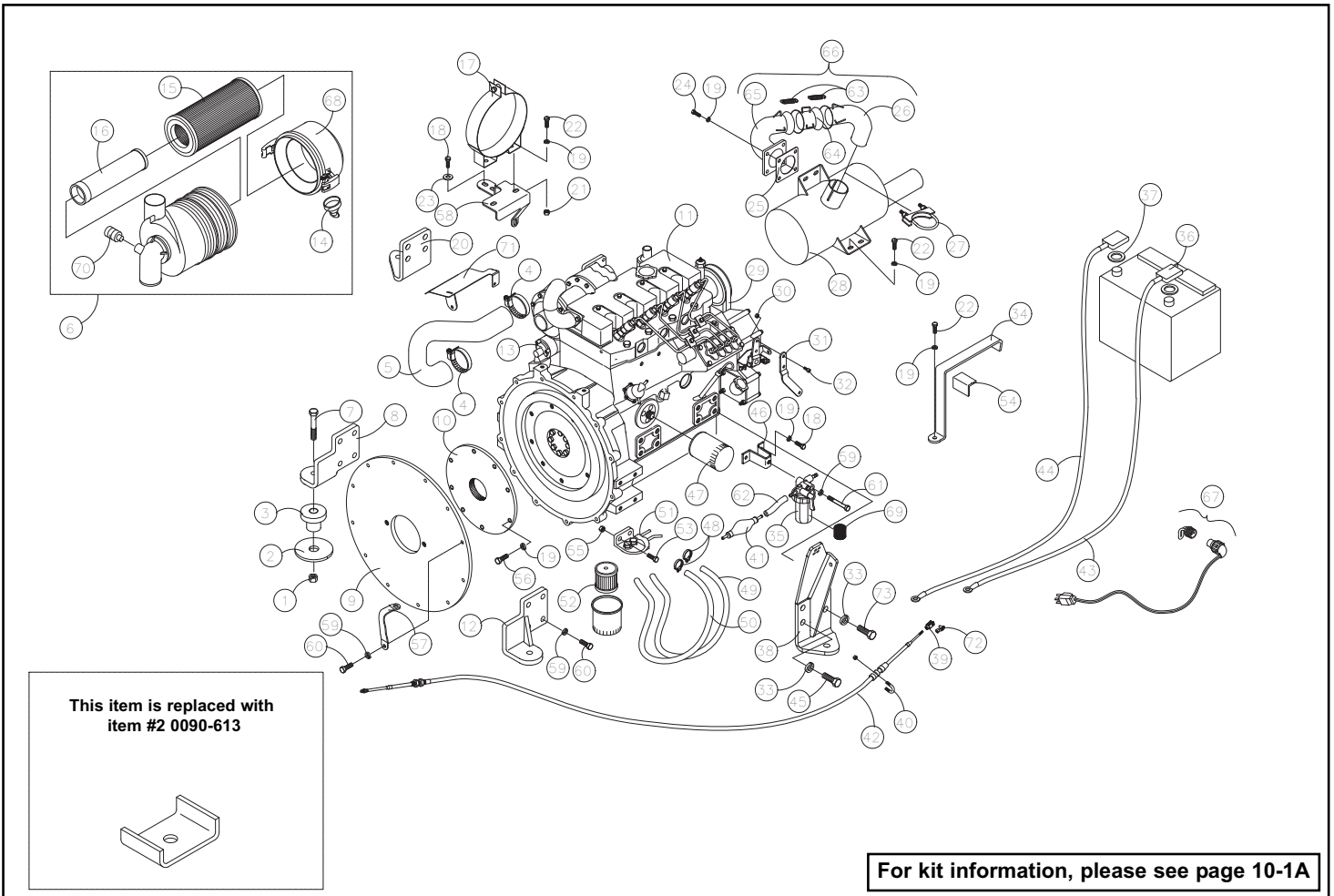

RADIATOR / OIL COOLER

RT- 60 valid from - 00600
R190T valid from - 00300

Chapter 2

REF. NO.	PART NUMBER	QTY.	DESCRIPTION	REF. NO.	PART NUMBER	QTY.	DESCRIPTION
1	0200-336	4	CAPSCREW,HH,M6x1.0x40				
2	8102-040	11	CAPSCREW,HH,1/4-20 UNCx.75,GD8				
3	8051-212	11	WASHER,SPRING LOCK,1/4,ZN				
4	8050-222	11	WASHER,WROUGHT,1/4,STD,ZN				
5	0200-225	1	GUARD,FAN,LH				
6	0200-226	1	GUARD,FAN,RH				
7	0200-103	1	FAN,ENGINE,17" (SEE NOTE)				
8	0304-035	1	HOSE,RADIATOR,TOP				
9	0303-238	2	CLAMP,HOSE				
10	8040-366	11	NUT,1/4-20UNC,NYLOK				
11	8102-222	4	CAPSCREW,HH,3/8-16 UNCx1.0,GD8				
12	0200-358	1	CAP,RADIATOR,7PSI				
13	8060-728	8	RIVET,BLIND3/16X.550 1Y SSB66S				
14	0304-444	1	HOSE,7/16 x 5/16 POLY,3FT				
15	0200-492	1	ASSY,COOLER				
16	2030-097	2	ADAPTER,FS6400-12-16-0				
17	2030-040	1	SHROUD,3024cT				
18	0304-036	1	HOSE,RADIATOR,BOTTOM				
19	2030-117	1	MNT,SHROUD,RH				
20	2030-116	1	MNT,SHROUD,LH				
21	0200-507	1	PACER,FAN,3024C				
22	8102-224	6	CAPSCREW,HH,3/8-16UNCx1.25,GD8				
23	8050-262	12	WASHER,WROUGHT,5/16,STD,ZN				
24	8040-486	10	NUT,HEX,NYLOCK,3/8-16 UNC,ZN				
25	0302-965	8	WASHER,RIVET,#7				
26	0307-439	2	ADAPTER,PLUG,8MB				
27	0200-360	1	SEAL,SHROUD,BOTTOM				
28	0200-359	1	SEAL,SHROUD,TOP				
29	2030-079	1	HOSE,12G1,12FFORX90S,12FFORX,6				
30	2030-078	1	HOSE,12G1,12FFORX90S,12FFORX90				
31	8051-272	4	WASHER,SPRING LOCK,3/8,ZN				
32	2030-278	1	PLATE DAM AIR				
33	8050-282	8	WASHER,WROUGHT,3/8,STD,ZN				
34	0303-240	2	CLAMP, HOSE				
35	8040-366	1	NUT,HEX,NYLOCK,1/4-20 UNC,ZN				
36	8050-240	1	WASHER,STAINLESS,1/4",				
37	0090-457	1	CAPSCREW 1/4-20 X 1				

NOTE: Item 7, 0200-103 Fan 17", must be purchased as a complete assembly. Individual components will not be sold seperately.

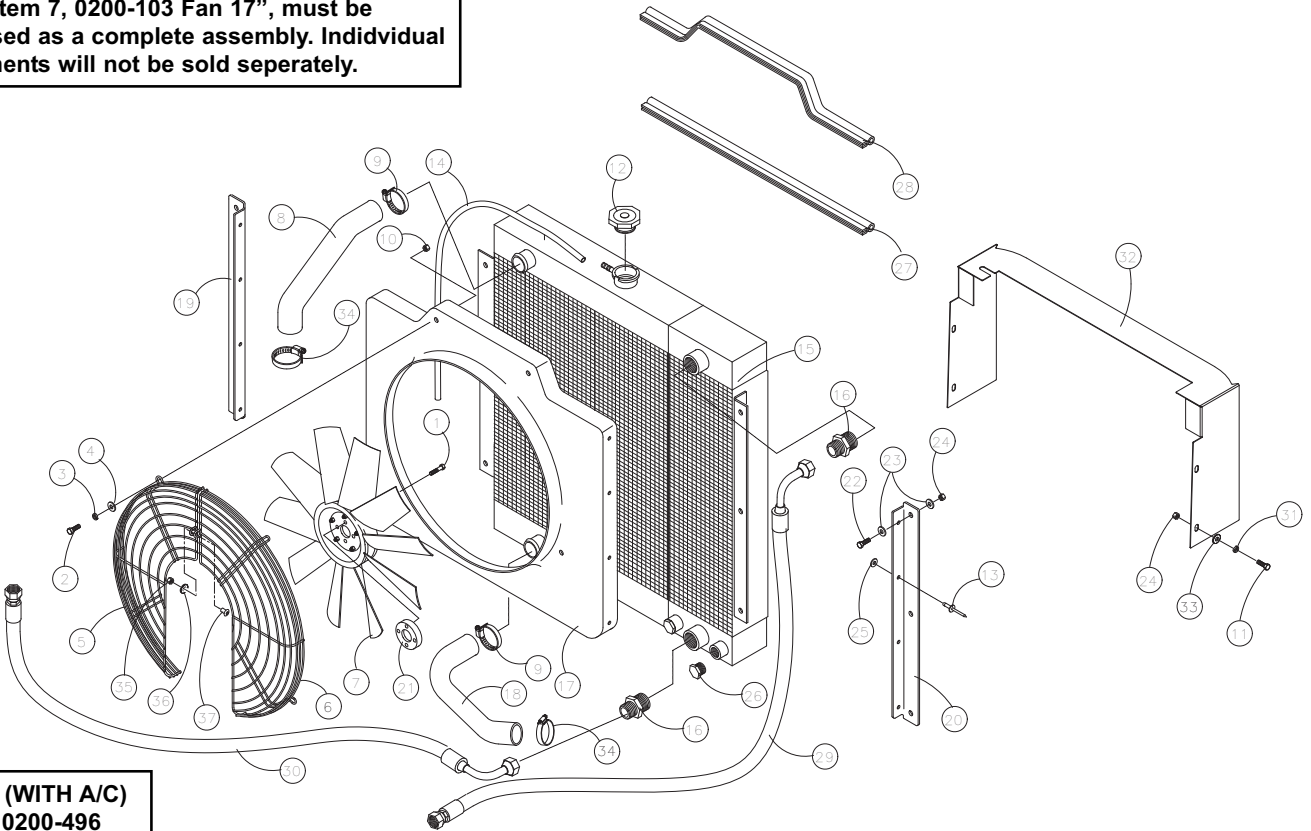

**ITEM 6 (WITH A/C)
P/N: 0200-496**

**ITEM 21 (WITH A/C)
P/N: 0200-533**

Chapter 3

Hydraulic Components

3-1 Hydraulic Reservoir

RT-60 Serial # valid from - 00600. 3-1A

R190T Serial # valid from - 00300. 3-1A

3-2 Lift Arm Assembly

RT-60 Serial # valid from - 00600. 3-2A

R190T Serial # valid from - 00300. 3-2A

3-3 Lift Arm Tubes And Fittings

RT-60 Serial # valid from - 00600. 3-3A

R190T Serial # valid from - 00300. 3-3A

3-4 Hydraulic Control

RT-60 Serial # 00600 - 00622. 3-4A

R190T Serial # 00300 - 00460 3-4A

RT-60 Serial # Valid From - 00623. 3-4B

R190T Serial # Valid From - 00461 3-4B

3-5 Drive / Auxilliary Pump

RT-60 Serial # 00600 - 00622. 3-5A

R190T Serial # 00300 - 00460 3-5A

RT-60 Serial # Valid From - 00623. 3-5B

R190T Serial # Valid From - 00461 3-5B

* **Parts manuals are updated on a regular basis. Always refer to the current online version to ensure you have the most up to date information prior to ordering parts.**

NOTE: Ordering parts that are painted requires a specific part number format. Please refer to page II of this manual for paint code and ordering information.

HYDRAULIC RESERVOIR ASSEMBLY

RT- 60 valid from - 00600
R190T valid from - 00300

Chapter 3

REF. NO.	PART NUMBER	QTY.	DESCRIPTION	REF. NO.	PART NUMBER	QTY.	DESCRIPTION
1	0200-276	1	SCREEN,SUCTION				
2	0304-450	1	VALVE,RELIEF,RES.				
3	0304-832	1	CAP,SLOSH PROOF,0 PSI				
4	0304-452	1	ASSY,COVER,ACCESS				
5	0200-203	1	ASSY,FILTER,HYD,4-BOLT				
6	0200-204	1	ELEMENT,FILTER,MP				
7	0304-642	1	GAUGE,SIGHT 5"				
8	0307-879	1	SWITCH,TEMP,OIL,225° F				
9	8102-134	1	CAPSCREW,HH,5/16-18UNCx1.25GD8				
10	8102-132	3	CAPSCREW,HH,5/16-18UNCx1.0 GD8				
11	8040-426	4	NUT,HEX,NYLOCK,5/16-18 UNC,ZN				
12	0302-713	1	ADAPTER,O-RING TO FLARE (4-6)				
13	2031-032	1	WLMT,RESERVOIR				
14	0304-384	2	CLAMP,HOSE # 16				
15	0304-442	1	HOSE,RES.				
16	0200-325	1	O-RING,FILTER CAP				
17	0304-621	1	ADAPTER,4MJ-6MB-4MJ				
18	0200-221	1	GASKET,COVER,ACCESS				
19	8104-132	4	CAPSCREW,HH 5/16-24UNF x 1 GD 8				
20	0310-321	1	ADAPTER,12MFFOR-12MB90ADAPTER				

ITEM 16 INCLUDES ALL IDENTIFIED O-RINGS

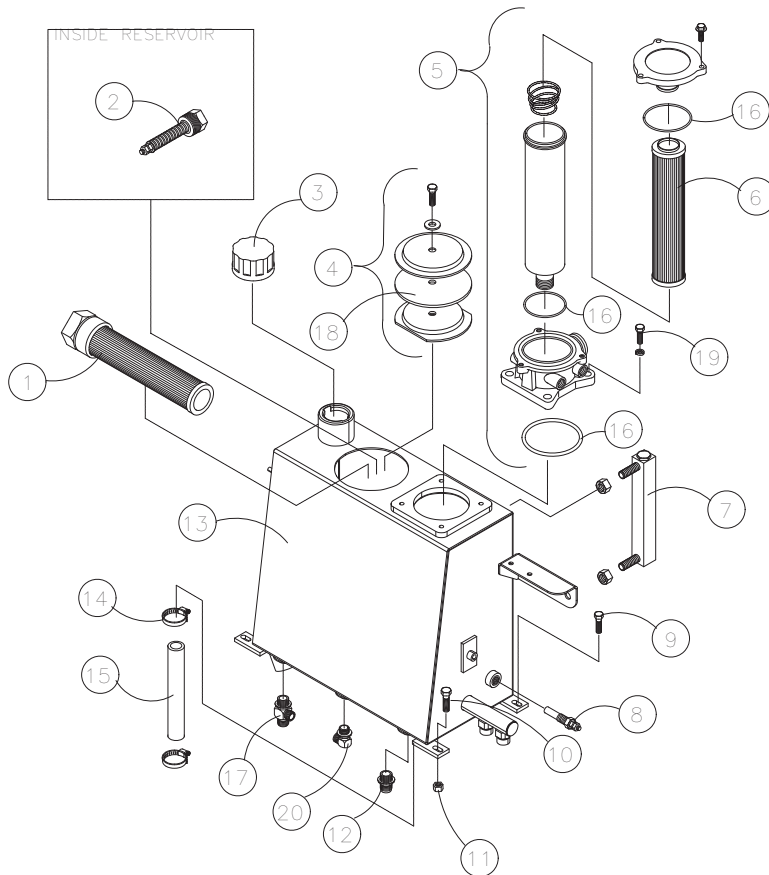

LIFT ARM ASSEMBLY

RT- 60 valid from - 00600
R190T valid from - 00300

Chapter 3

REF. NO.	PART NUMBER	QTY.	DESCRIPTION	REF. NO.	PART NUMBER	QTY.	DESCRIPTION
1	0201-771	1	HARNES,ELEC,AUX,RC100/85/60				
2	2010-689	1	HARNES AUX PWR ACT				
3	2030-562	4	WLMT PIN 1.5 X 4.51				
4	0300-607	10	ZERK,GREASE,1/4-28				
5	8011-222	4	BOLT,CARRIAGE,3/8-16 UNCx1.0,Z				
6	0314-269	6	NUT,FLANGE,TOPLK,3/8-16UNC,GD8				
7	2030-824	2	CYLINDER BOOM				
8	2030-546	2	WLMT PIN BOOM				
9	2030-069	2	HOSE,10M4K,10FFORX,10FFORX,28.				
10	0201-770	1	CAP,W/CHAIN				
11	2030-070	2	HOSE,10M4K,10FFORX,10FFORX,50.				
12	0310-345	8	ADAPTER,8MFFOR-8MB				
13	2030-535	1	WLMT LOADER RT50/60				
14	0003-053	2	BUSHING Ø1.50IDx2.00				
15	0304-496	1	PAD,SKID				
16	8102-220	2	CAPSCREW,HH,3/8-16x0.75",GD8				
17	2030-654	2	BUSHING Ø1.50IDx2.50				
18	2030-550	2	WLMT PIN 1.5" x 5.375"				
19	2040-115	2	WLMT PIN 6.00"				
20	2030-803	1	CYLINDER BUCKET TILT LH				
21	8102-222	4	CAPSCREW,HH,3/8-16 UNCx1.0,GD8				
22	2030-804	1	CYLINDER BUCKET TILT RH				
23	2030-573	4	BUSHING CONNEX 1.5ID X 1.75OD x 1 7/16L				
24	2030-655	2	BUSHING Ø1.50IDx3.00				
25	2030-580	4	BUSHING SPRING 1.5" ID x 2" OD				
26	0003-053	2	BUSHING Ø1.50IDx2.375				
27	2040-325	2	WLMT, PIN, QA TILT,6.00				
28	0090-562	4	PLUG				
29	0090-382	2	ZERK 1/4-28 45 DEGREE LONG				
30	8111-224	2	BOLT,CARRIAGE,3/8-16UNCX1.25,GD8				

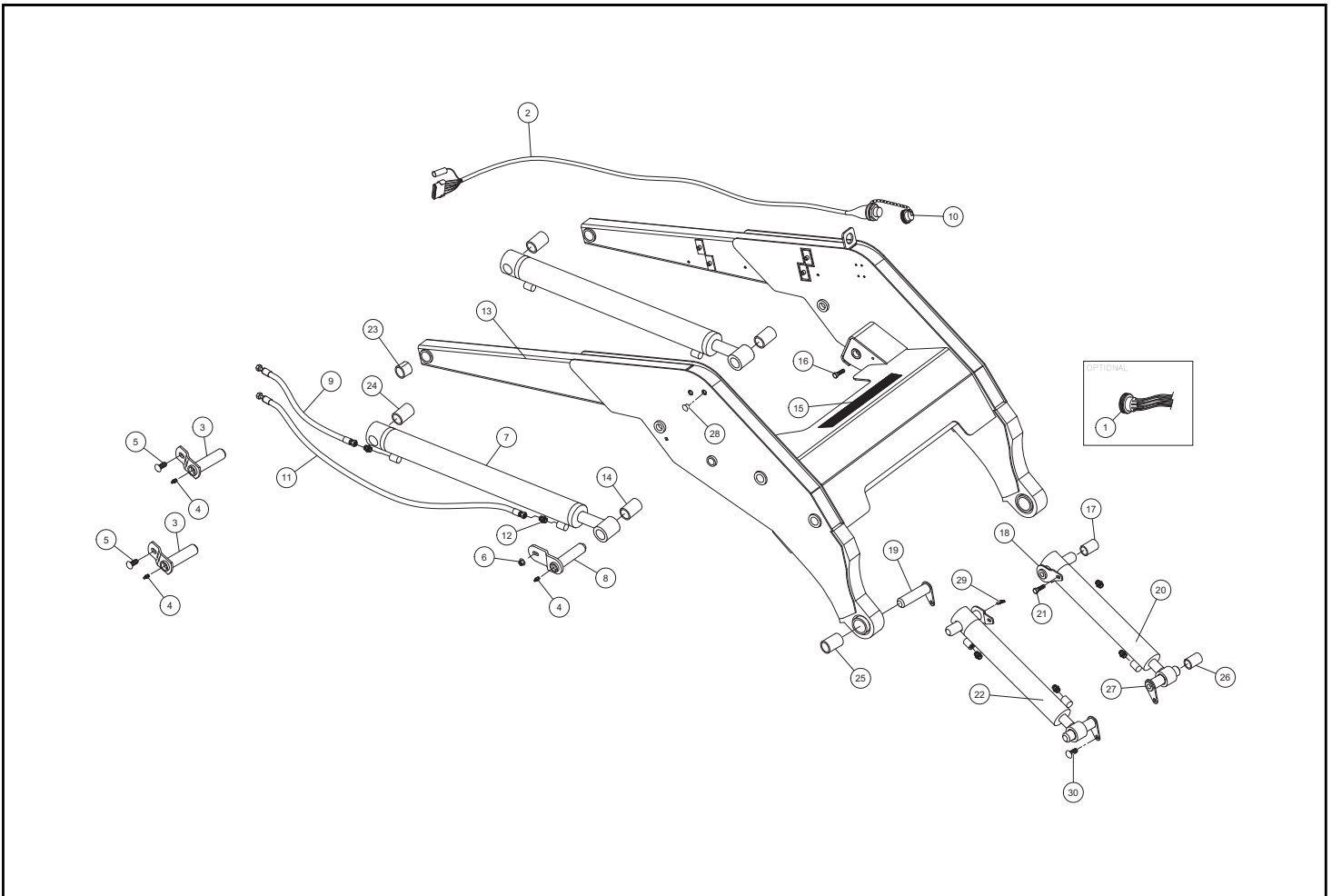

LIFT ARM TUBES AND FITTINGS

RT- 60 valid from - 00600
R190T valid from - 00300

Chapter 3

REF. NO.	PART NUMBER	QTY.	DESCRIPTION	REF. NO.	PART NUMBER	QTY.	DESCRIPTION
1	2030-010	1	TUBE,BUCKET,LOWER				
2	2030-009	1	TUBE,BUCKET,UPPER				
3	2030-008	1	TUBE,CASE DRAIN,QD				
4	2030-001	1	TUBE,AUX,UPPER,QD				
5	2030-002	1	TUBE,AUX,LOWER,QD				
6	0310-567	1	ADAPTER,8MFFOR-6MB				
7	0310-831	4	CLAMP, SET, T2062-PP				
8	0310-584	9	PLATE,COVER TCP-T2				
9	8102-134	9	CAPSCREW,HH,5/16-18UNCx1.25GD8				
10	0201-658	2	ADAPTER,10MFFOR-8MB-S				
11	0304-876	1	MANIFOLD,AUX,HYD				
12	8102-050	4	CAPSCREW,HH,1/4-20,UNC,2.75ZN,				
13	0304-188	1	PLUG,6 ORING,HH				
14	0200-296	2	ADAPTER,O-RING HEX NIPPLE,10-8				
15	8040-366	4	NUT,HEX,NYLOCK,1/4-20 UNC,ZN				
16	0310-076	1	COUPLER,QUICK,FF,FEMALE,7/8-14				
17	0310-077	1	COUPLER,QUICK,FF,MALE,7/8-14UN				
18	0310-241	1	COVER,DUST,1/2,F				
19	0310-240	1	COVER,DUST,1/2,M				
20	0201-402	5	CLAMP,SET,2050-PP				
21	0201-224	7	COVER,CLAMP,COP-2				
22	8102-044	14	CAPSCREW,HH,1/4-20UNCx1.25,GD8				
23	0201-223	2	CLAMP,SET,2062-PP				
24	0201-488	2	HOSE,8M4K,23.50"				
25	0201-489	2	HOSE,8M4K,17.50"				
26	0201-838	1	SPOOL,VALVE,QD BLOCK				
27	0402-886	1	KIT,DUST,COVER,RC60/50				
28	2030-070	2	HOSE,10M4K,10FFORX,10FFORX,50				
29	2030-137	1	HOSE,6M4K,6G6FFORX90S,6G8FFORX				

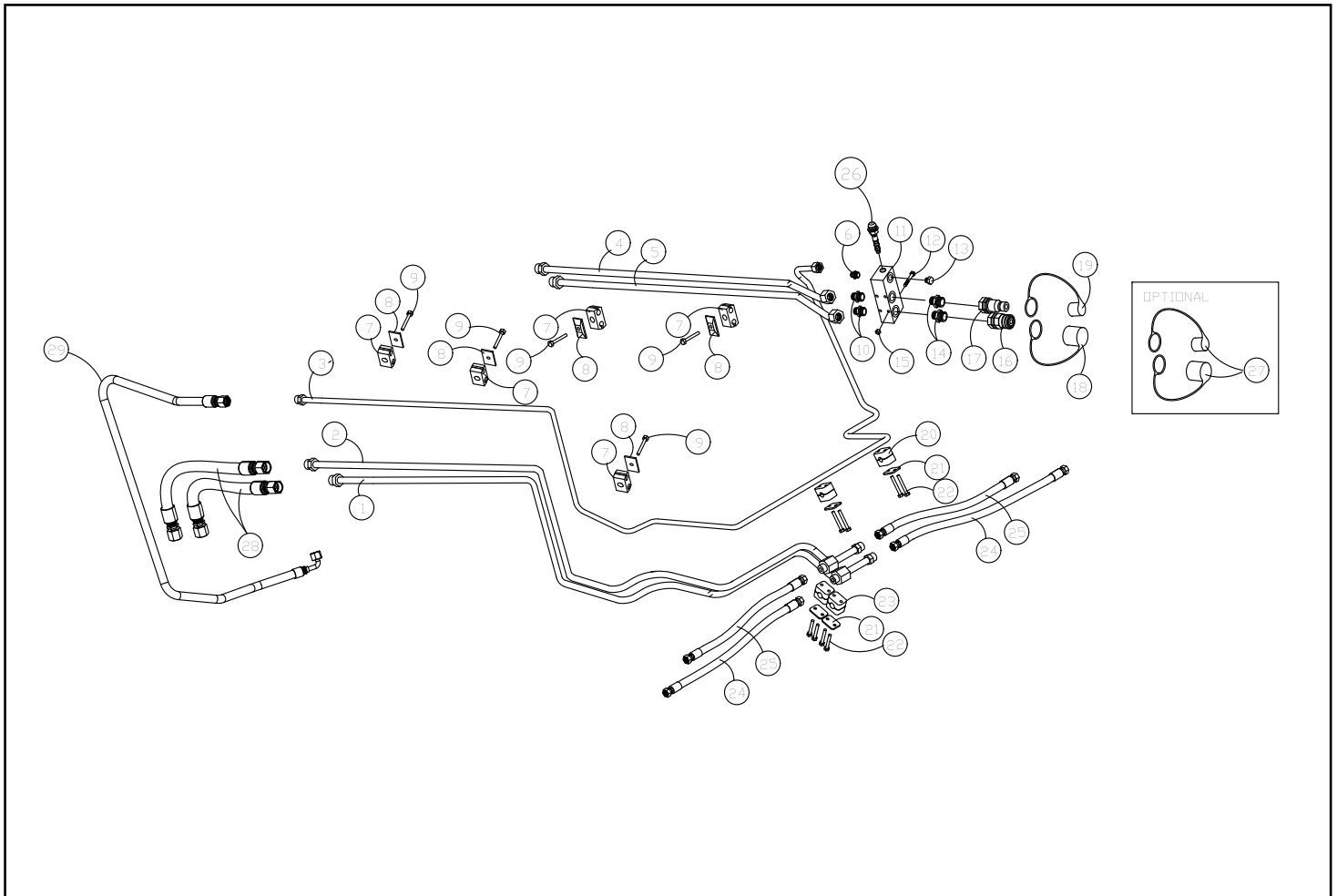

HYDRAULIC CONTROL ASSEMBLY

RT- 60 00600 - 00622
R190T 00300 - 00460

Chapter 3

REF. NO.	PART NUMBER	QTY.	DESCRIPTION	REF. NO.	PART NUMBER	QTY.	DESCRIPTION
1	2030-071	2	HOSE,10M4K,10FFORX,10FFORX,22.	41	2030-818	2	RELIEF, WORK PORT, 3500 PSI ANTI CAVITY
2	2030-003	1	TUBE,AUX, TOP, VALVE	42	0201-319	1	ADAPTER,FS6801-04-06-NW0
3	2030-004	1	TUBE,AUX, LOWER, VALVE	43	0310-321	1	ADAPTER,12MFFOR-12MB90
4	0310-328	2	ADAPTER,6MFFOR-6MB-90	44	2030-817	1	VALVE,LOADER
5	2031-028	2	HOSE -6 1000PSI 6FFORX 6FFORX 41.75"	45	0201-557	1	VALVE,RELIEF,PORT,3000PSI
6	2030-227	2	HOSE (OPTIONAL)	46	0200-330	1	BRACKET,FILTER
7	0310-329	3	ADAPTER,6MFFOR-6MB	47	0200-326	1	ADAPTER,TEST PORT,#4 BLK
8	2031-027	1	HOSE -6 1000PSI 6FFORX 6FFORX 57.5"	48	2030-118	1	TUBE,RETURN,VALVE
9	0304-441	1	SWITCH,PRESSURE NASON	49	2030-005	1	TUBE,BOOM,LOWER,VALVE
10	0201-309	18	ADAPTER,FS6400-04-06-0	50	2030-011	1	TUBE,BOOM,UPPER,VALVE
11	2030-675	1	ASSY,JOYSTICK,LH	51	2030-111	1	TUBE,LEVELER,REAR
12	0307-882	2	TIE,CABLE,BLACK,18.1",W/STL INSERT BT-5LH-LO	52	2030-113	1	TUBE,LEVELER,FRONT
13	2030-054	1	HOSE,4G1,6FFORX90S,4FFORX,48.00"	53	2030-103	1	TUBE,LEVELER,TOP
14	2030-053	2	HOSE,4G1,4FFORX90S	54	0201-668	2	ADAPTER,FS6801-10-10NWO
15	2030-036	1	HOSE,4G1,4FFORX90M,6FFORX,36.0	55	0201-625	1	VALVE,SELF-LEVELING
16	2030-048	1	HOSE,4G1,4FFORX90S,4FJX,52.00"	56	2030-104	1	TUBE,BOOM,LEVELER
17	0201-311	8	ADAPTER,FS6400-04-04-0	57	0118-168	1	SPOOL,SOLENOID,2POSITION,4WAY
18	0200-364	5	SOLENOID,W/DEUTSCH CONNECTOR	58	2030-222	1	TUBE LOWER QUICK ATTACH (OPTIONAL)
19	2030-064	1	ASSY,LINE,CONTROL,BOTTOM,AUX.	59	2030-221	1	TUBE UPPER QUICK ATTACH (OPTIONAL)
20	2030-067	1	ASSY,LINE,CONTROL, TOP,AUX	60	2030-232	1	TUBE QA C PORT (OPTIONAL)
21	0118-164	1	SPOOL,SOLENOID,3POSITION,4WAY	61	2030-233	1	TUBE QA D PORT (OPTIONAL)
22	0118-165	2	SPOOL,SOLENOID,2POSITION,3WAY	62	8102-134	4	CAPSCREW,HH,5/16-18UNCx1.25GD8 (OPTIONAL)
23	0304-516	1	MAGNET,DETENT	63	0310-584	4	PLATE,COVER TCP-T2 (OPTIONAL)
24	2030-661	1	ASSY,JOYSTICK,RH	64	0201-225	4	CLAMP,SET,T2038-PP (OPTIONAL)
25	0201-152	2	GRIP,CONTROL	65	2030-819	4	RELIEF, WORK PORT, 3500 PSI DIRECT ACTING
26	0201-775	2	BOOT,JOYSTICK,RH	66	2031-077	1	HOSE, -6, 1000PSI, 6FFORX,
27	8104-040	8	CAPSCREW,HH 1/4-28UNF x .75 GD8				
28	8040-396	8	NUT,HEX,NYLOCK,1/4-28 UNF,ZN				
29	2030-055	1	ASSY,LINE,CONTROL,CURL,BUCKET				
30	2030-057	1	ASSY,LINE,CONTROL,DOWN,LOADER				
31	2030-059	1	ASSY,LINE,CONTROL,DUMP,BUCKET				
32	2030-062	1	ASSY,LINE,CONTROL,UP,LOADER				
33	0304-395	2	CLAMP,PILOT LINES				
34	0310-330	2	ADAPTER,10MFFOR-8MB-90				
35	0201-658	2	ADAPTER,10MFFOR-8MB-SV				
36	0310-339	2	ADAPTER,CAP,10FFOR 6V9831(FS0304-C-10)				
37	2030-112	1	TUBE,BUCKET,UPPER,LEVELER				
38	2030-110	1	TUBE,BUCKET,LOWER,LEVELER				
39	0310-318	4	ADAPTER,10MFFOR-10MB				
40	0310-313	1	ADAPTER,12MFFOR-12MB				

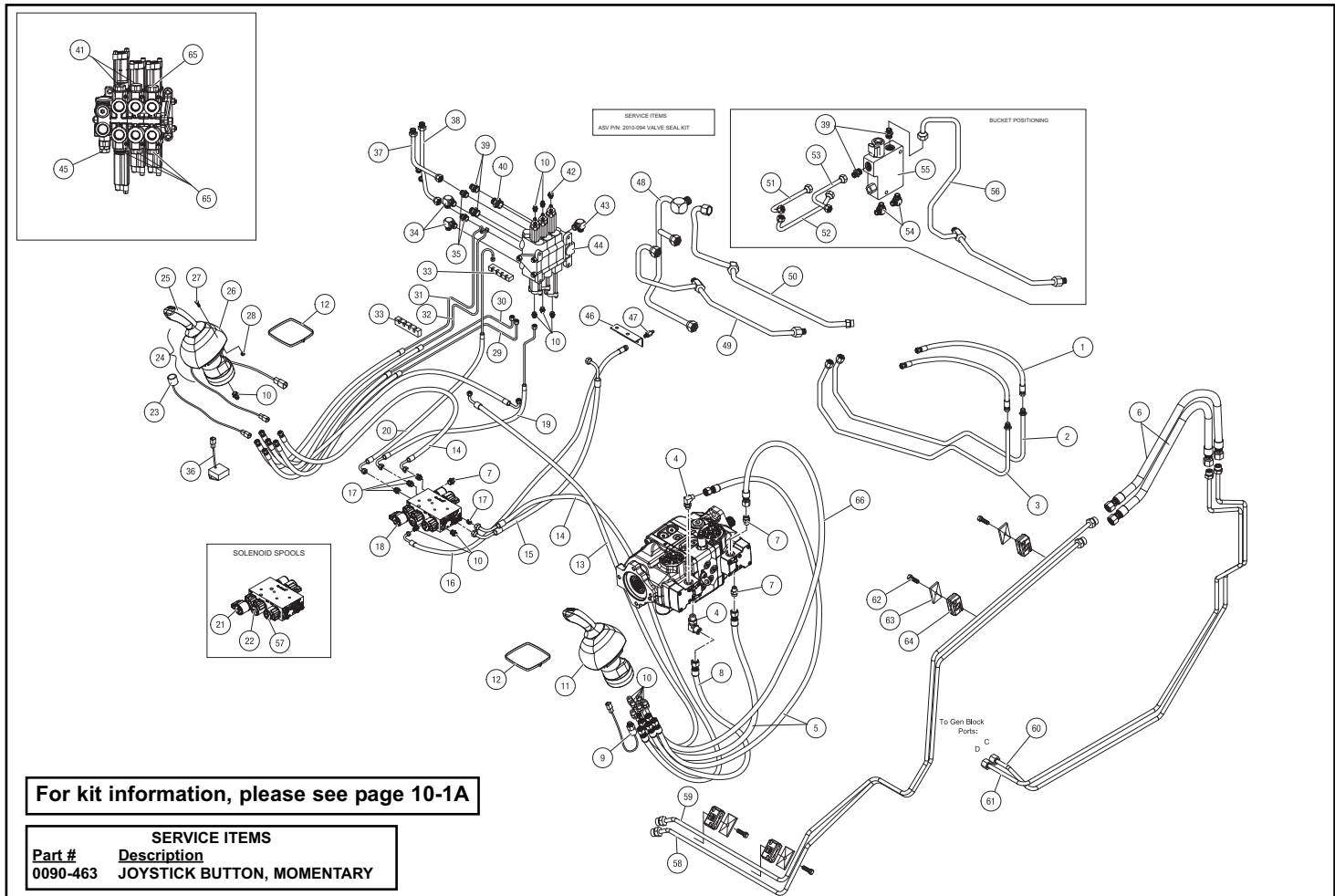

HYDRAULIC CONTROL ASSEMBLY

RT- 60 valid from - 00623
R190T valid from - 00461

Chapter 3

REF. NO.	PART NUMBER	QTY.	DESCRIPTION
1	2030-232	1	TUBE QA C PORT (OPTIONAL)
2	2030-661	1	ASSY,JOYSTICK,RH
3	0310-467	1	CLAMP,WIRE,1.0,RBC-1
4	0310-465	1	CLAMP,WIRE,5/8,RBC-5/8
5	8050-262	1	WASHER,WROUGHT,5/16,STD,ZN
6	8104-040	8	CAPSCREW,HH 1/4-28UNFx .75 GD8
7	8040-396	8	NUT,HEX,NYLOCK,1/4-28 UNF,ZN
8	0307-882	2	TIE,CABLE,BLACK,18.1",W/STL IN
9	2030-062	1	ASSY,LINE,CONTROL,UP,LOADER
10	2030-059	1	ASSY,LINE,CONTROL,DUMP,BUCKET
11	2030-110	1	TUBE,BUCKET,LOWER,LEVELER
12	0201-311	8	ADAPTER,FS6400-04-04-0
13	0310-330	2	ADAPTER,10MFFOR-8MB-90
14	0201-658	2	ADAPTER,10MFFOR-8MB-S
15	8051-242	1	WASHER,SPRING LOCK,5/16,ZN
16	0310-313	1	ADAPTER,12MFFOR-12MB
17	0201-309	14	ADAPTER,FS6400-04-06-0
18	0201-319	1	ADAPTER,FS6801-04-06-NW0
19	0310-321	1	ADAPTER,12MFFOR-12MB90
20	2030-817	1	VALVE,LOADER
21	2030-067	1	ASSY,LINE,CONTROL,TOP,AUX
22	2030-057	1	ASSY,LINE,CONTROL,DOWN,LOADER
23	2030-055	1	ASSY,LINE,CONTROL,CURL,BUCKET
24	0200-330	1	BRACKET,FILTER
25	2030-064	1	ASSY,LINE,CONTROL,BOTTOM,AUX.
26	2030-675	1	ASSY,JOYSTICK,LH
27	0201-314	3	ADAPTER,FS6801-04-04-NW0
28	2030-004	1	TUBE,AUX,LOWER,VALVE
29	2030-003	1	TUBE,AUX,TOP,VALVE
30	0304-395	2	CLAMP,PILOT LINES
31	2030-052	1	HOSE,4G1,4FFORX90S,4FFORX,47.5
32	2030-050	1	HOSE,4G1,4FFORX,4FFORX,51.00"
33	2030-049	1	HOSE,4G1,4FFORX,4FFORX,47.00"
34	2030-054	1	HOSE,4G1,6FFORX90S,4FFORX,48.0
35	2030-053	2	HOSE,4G1,4FFORX90S,4FFORX,62.0
36	2030-222	1	TUBE LOWER QUICK ATTACH (OPTIONAL)
37	2030-048	1	HOSE,4G1,4FFORX90S,4FJX,52.00"
38	0310-329	3	ADAPTER,6MFFOR-6MB
39	0200-326	1	ADAPTER,TEST PORT,#4 BLK
40	2030-221	1	TUBE UPPER QUICK ATTACH (OPTIONAL)

REF. NO.	PART NUMBER	QTY.	DESCRIPTION
41	2030-036	1	HOSE,4G1,4FFORX90M,6FFORX,36.0
42	2030-227	2	HOSE (OPTIONAL)
43	2030-233	1	TUBE QA D PORT (OPTIONAL)
44	2030-112	1	TUBE,BUCKET,UPPER,LEVELER
45	2030-051	1	HOSE,4G1,4FFORX90S,4FFORX,41.5
46	2030-071	2	HOSE,10M4K,10FFORX,10FFORX,22.
47	0304-441	1	SWITCH,PRESSURE
48	8102-134	1	CAPSCREW,HH,5/16-18UNCx1.25GD8 ZN
49	2030-118	1	TUBE,RETURN,VALVE
50	2030-005	1	TUBE,BOOM,LOWER,VALVE
51	2030-011	1	TUBE,BOOM,UPPER,VALVE
52	0118-168	1	SPOOL,SOLENOID,2POSITION,4WAY
53	0201-152	2	GRIP,CONTROL
54	0201-775	1	BOOT,JOYSTICK,RH
55	0304-516	1	MAGNET,DETENT
56	0201-774	1	BOOT,JOYSTICK,LH
57	0200-364	6	SOLENOID,W/DEUTSCH CONNECTOR
58	0118-165	3	SPOOL,SOLENOID,2POSITION,3WAY
59	0118-164	1	SPOOL,SOLENOID,3POSITION,4WAY
60	2030-818	2	RELIEF, WORK PORT, 3500 PSI ANTI CAVITY
61	0201-557	1	VALVE,RELIEF,PORT,3000PSI
62	0201-225	4	CLAMP,SET,T2038-PP (OPTIONAL)
63	0310-584	4	PLATE,COVER TCP-T2 (OPTIONAL)
64	8102-134	4	CAPSCREW,HH,5/16-18UNCx1.25GD8 (OPTIONAL)
65	0201-323	1	RELAY,LATCHING
66	2010-734	4	ADAPTER ORIFICE .040" FS6400-04-06
67	2030-819	2	RELIEF, WORK PORT, 3500 PSI DIRECT ACTING

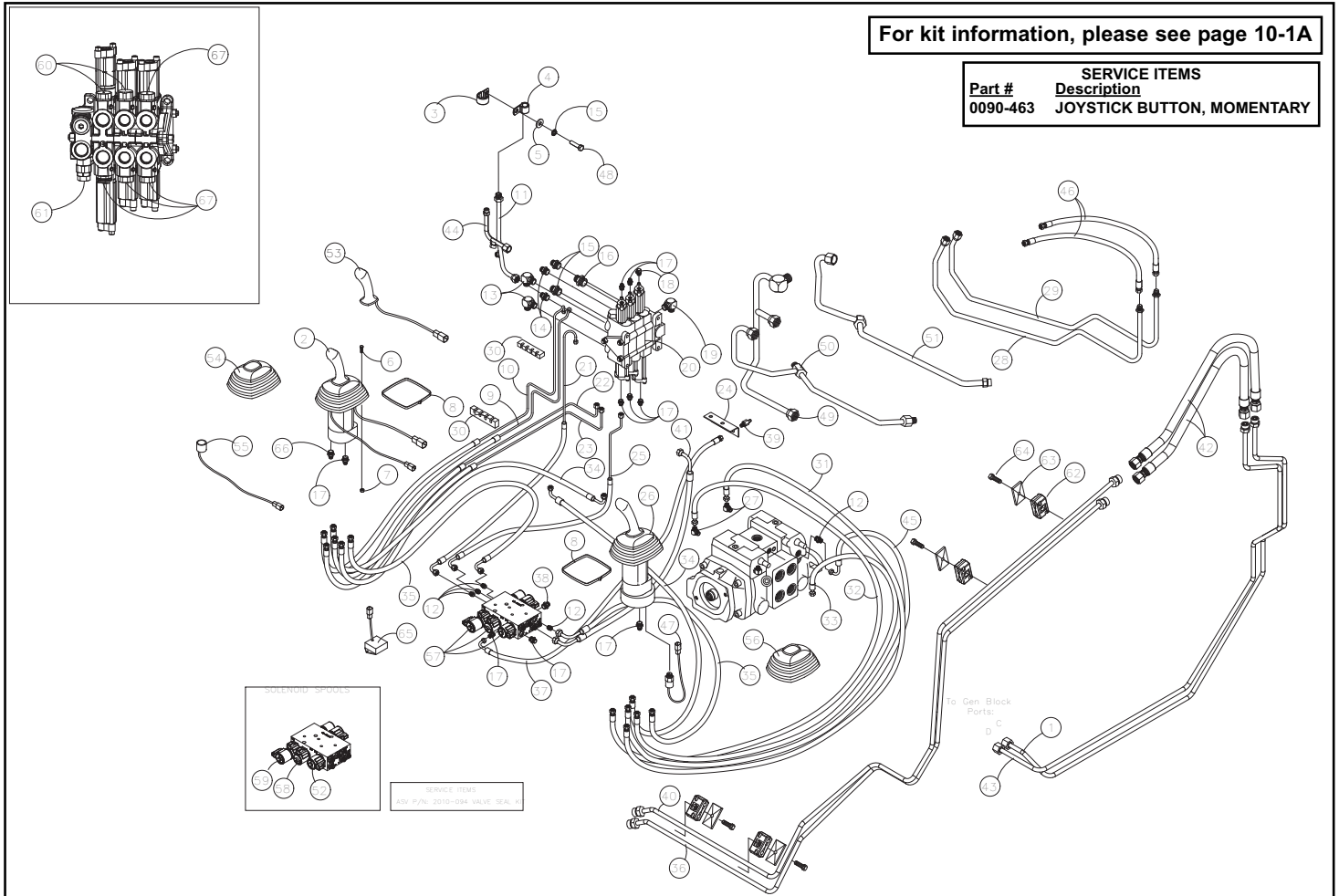

DRIVE / AUXILLIARY PUMP ASSEMBLY

RT- 60 00600 - 00622
R190T 00300 - 00460

Chapter 3

REF. NO.	PART NUMBER	QTY.	DESCRIPTION	REF. NO.	PART NUMBER	QTY.	DESCRIPTION
1	2031-015	1	HOSE 8G1 8FFORX90L 8FFORX 46.63"	41	8051-272	2	WASHER,SPRING LOCK,3/8,ZN
2	2031-016	1	HOSE 8G1 8FFORX90L 8FFORX 49.5"	42	0310-345	1	ADAPTER,8MFFOR--8MB
3	2031-023	1	HOSE CASE DRAIN TANDEM PUMP TO TANK	43	0090-228	1	ADAPTER 8FFORX-10MB-90 NWO FS6801-08-10-NWO
4	2031-031	1	HOSE -6 1000PSI 6FFORX 6FFORX 28.5"	44	0307-169	1	O-RING,4.0" ID x 4-3/16" OD BUNA 2-155
5	0700-172	8	FLANGE,HALF,12	45	0200-355	1	ADAPTER,SPLINE
6	0700-170	24	WASHER,21 x 22 x 2.5	46	2030-800	1	HOSE
7	0700-171	16	CAPSCREW,HH,M10 x 1.5 x 45	47	0310-328	1	ADAPTER,6MFFOR-6MB-90
8	2031-008	1	HOSE DRIVE LH FWD	48	0200-104	1	HUB,PUMP DRIVE,1 1/4" x 14
9	2031-015	1	HOSE 8G1 8FFORX90L 8FFORX 46.63"	49	2031-004	1	PUMP TANDEM H1
10	2031-007	1	HOSE DRIVE LH REVERSE	50	0404-370	1	KIT RELIEF VALVE CHARGE
11	2030-266	1	HOSE 4GI4FFORX454FFORX45,32.25"	51	0090-423	1	ADAPTER 4601-16-12-NOW
12	2030-263	1	HOSE 4GI4FFORX90S4FFORX, 32.25"	52	0200-172	2	COUPLING,SPLIT,CODE 61,0.75
13	0201-311	2	ADAPTER,FS6400-04-04-0	53	0090-474	1	CLAMP
14	0200-616	1	BLOCK PILOT GEN W/ QA PORTS				
15	0315-006	2	ADAPTER,FS6400-12-16-0				
16	2030-261	1	HOSE RH 2-SPD				
17	0201-654	4	ADAPTER,FS,6400,04,06,SHORT				
18	0310-345	2	ADAPTER,8MFFOR--8MB				
19	2031-011	1	TUBE CHARGE PUMP TO DA HYD TUBE .05" O.D.				
20	2031-009	1	HOSE DRIVE RH REVERSE				
21	2031-010	1	HOSE DRIVE RH FWD				
22	0200-171	2	COUPLING,SPLIT,CODE 61,1.25"				
23	0310-468	8	CAPSCREW,HH,M10x1.5x35,ZINC				
24	2031-030	1	HOSE -6 1000PSI 6FFORX 6FFORX 22.875"				
25	2031-014	1	WLMT TUBE SUCTION AUX PUMP				
26	8040-486	2	NUT,HEX,NYLOCK,3/8-16 UNC,ZN				
27	2031-022	1	TUBE CASE DRAIN DA BLOCK-PUMP TUBE .0375" O.D.				
28	0310-329	2	ADAPTER,6MFFOR-6MB				
29	0310-346	1	ADAPTER,8MFFOR-8MB-90^				
30	0090-234	1	ADAPTER 8FFOR-12MB FS6400-08-12-O				
31	8102-230	2	CAPSCREW,HH 3/8-16UNCx2.75 GD8				
32	0315-007	2	ADAPTER,FS6801-12-16-NW0				
33	2031-021	1	TUBE DA BLOCK TO TANDEM HYD TUBE .05" O.D.				
34	0090-228	1	ADAPTER 8MFOR-10MB				
35	0403-100	1	RELIEF POSI POWER				
36	0404-368	4	ASSEMBLY PLUG VALVE SCR				
37	0303-238	2	CLAMP,HOSE,				
38	0304-528	1	HOSE,RES,1.5x9				
39	7001-414	1	PUMP,HYD,AUX				
40	8102-222	2	CAPSCREW,HH,3/8-16 UNCx1.0.GD8,ZN				

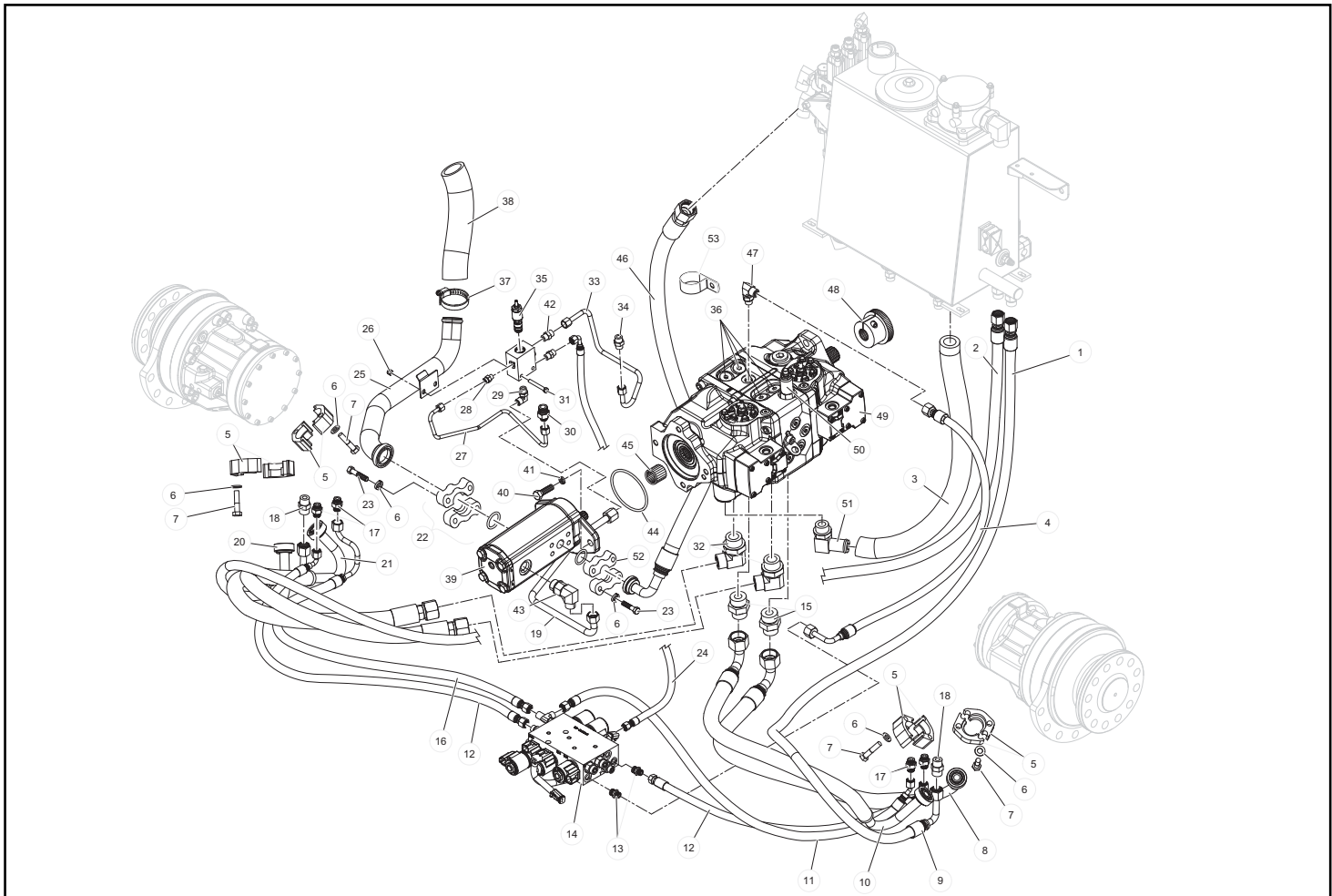

DRIVE / AUXILLIARY PUMP

RT- 60 valid from - 00623
R190T valid from - 00461

Chapter 3

REF. NO.	PART NUMBER	QTY.	DESCRIPTION	REF. NO.	PART NUMBER	QTY.	DESCRIPTION
1	2031-084	1	HOSE, -4, 1000 PSI, 4FFORX, 4FFORX, 30"	41	0201-634	1	ADAPTER,FS6804-04-04-04-NWO-FG
2	2030-291	1	BLOCK PILOT GEN W/QA PORTS	42	0201-309	6	ADAPTER,FS6400-04-06-0
3	0201-311	3	ADAPTER,FS6400-04-04-0	43	0310-329	4	ADAPTER,6MFFOR-6MB
4	8102-222	2	CAPSCREW,HH,3/8-16 UNCx1.0,GD8	44	0201-314	2	ADAPTER,FS6801-04-04-NWO
5	2031-080	1	HOSE, -12, 6000 PSI, 12FFORX, 12FFORX, 42"	45	2031-078	1	HOSE, -12, 6000 PSI, 12FFORX, 12FFORX, 30"
6	2031-081	1	HOSE, -12, 6000 PSI, 12FFORX, 12FFORX, 38"	46	2031-079	1	HOSE, -12, 6000 PSI, 12FFORX, 12FFORX, 27"
7	2031-085	1	HOSE, -8, 1000 PSI, 8FFORX, 8FFORX, 47"	47	0310-345	2	ADAPTER,8MFFOR--8MB
8	0201-654	4	ADAPTER,FS,6400,04,06,SHORT	48	0090-474	1	CLAMP
9	2031-088	1	HOSE, -4, 1000 PSI, 8FFORX, 8FFORX45, 31"	49	0201-319	2	ADAPTER,FS6801-04-06-NWO
10	2030-801	1	HOSE	50	0315-008	2	ADAPTER, HYD, 12 C5OLO-S,TRAP SEAL
11	2031-087	1	HOSE, -4, 1000 PSI, 4FFORX, 4FFORX45, 42"	51	0201-575	2	CAPSCREW,HH,1/2-13UNCx1.625,GD8
12	2031-083	1	HOSE, -8, 1000 PSI, 8FFORX, 8FFORX, 35"	52	0090-136	2	WASHER HARD 1.0 X .531 X .197
13	7000-744	1	ADAPTER				
14	0200-172	1	COUPLING,SPLIT,CODE 61,0.75"				
15	0201-658	1	ADAPTER,10MFFOR-8MB-S				
16	0310-321	2	ADAPTER,12MFFOR-12MB90				
17	0200-104	1	HUB,PUMP DRIVE,1 1/4" x 14 TOO				
18	2046-373	1	PUMP,TANDEM,TRANSMISSION (SEE NOTE)				
19	0201-316	2	ADAPTER,FS6801-L-12-12-NWO				
20	2030-072	1	MANIFOLD,DRAIN,CASE				
21	2030-800	1	HOSE				
22	2030-047	1	HOSE,6G1,6FFORX90S,6FFORX,41.5				
23	0304-528	1	HOSE,RES,1.5x9				
24	0303-238	4	CLAMP,HOSE				
25	0200-355	1	ADAPTER,SPLINE				
26	0307-169	1	O-RING,4.0" ID x 4-3/16" OD				
27	0200-124	1	TUBE,INTAKE,RC 50				
28	0200-171	1	COUPLING,SPLIT,CODE 61,1.25"				
29	7001-414	1	PUMP,HYD,AUX				
30	8051-272	2	WASHER,SPRING LOCK,3/8,ZN				
31	2030-046	1	HOSE,6G1,6FFORX90S,6FFORX90L,2				
32	0310-468	8	CAPSCREW,HH,M10x1.5x35,ZINC PL				
33	0301-781	8	WASHER,SPLIT LOCK,10mm,ZN				
34	0310-294	1	O-RING,#222,1.50x1.75x.13				
35	0201-558	1	O-RING,0.984IDx0.139CS				
36	0403-001	4	O-RING VALVE RELIEF				
37	0403-002	4	O-RING BACK-UP VALVE RELIEF				
38	0201-876	4	VALVE,RELIEF,5500 PSI				
39	0403-100	1	RELIEF POSI POWER				
40	2030-721	1	HOSE, -4, 1000 PSI, 4FFORX, 4FFORX90M, 25.5"				

For kit information, please see page 10-1A

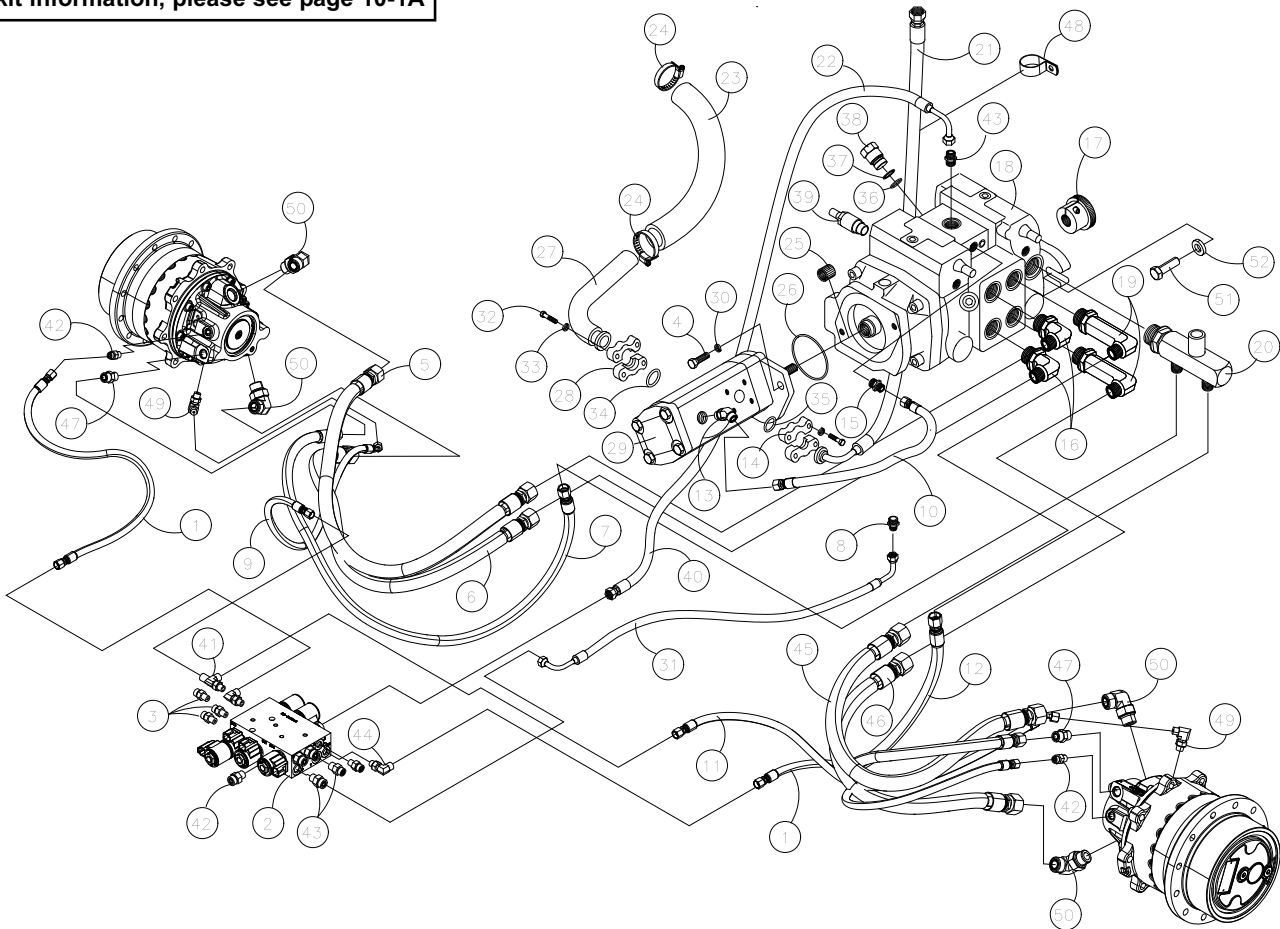

Chapter 4

Electrical

4-1 Light Bar Assembly

RT-60 Serial # 00600 - 006674-1A

R190T Serial # 00300 - 005114-1A

RT-60 Serial # 00668 - 041024-1B

R190T Serial # 00512 - 041024-1B

RT-60 Serial # valid from - 04103.4-1C

R190T Serial # valid from - 04103.4-1C

4-2 Fuse Panel Assembly

RT-60 Serial # valid from - 00600.4-2A

R190T Serial # valid from - 00300.4-2A

- * **Parts manuals are updated on a regular basis. Always refer to the current online version to ensure you have the most up to date information prior to ordering parts.**

NOTE: Ordering parts that are painted requires a specific part number format. Please refer to page II of this manual for paint code and ordering information.

LIGHT BAR ASSEMBLY

RT- 60 00600 - 00667
R190T 00300 - 00511

Chapter 4

REF. NO.	PART NUMBER	QTY.	DESCRIPTION	REF. NO.	PART NUMBER	QTY.	DESCRIPTION
1	2045-755	4	KIT LIGHTS 35W W/ HARNESS				
2	2045-756	4	LIGHT 35W W/BEZEL (SEE NOTE)				
3	0201-595	2	HARNESS,LIGHT,DOUBLE				
4	2030-331	1	DECAL DASH PANEL				
5	2030-241	1	CONSOLE MACHINED				
6	2030-245	1	LIGHT DOME				
7	0304-411	1	PLUG, HOLE, 3/4", PLASTIC				
8	0310-137	4	FRAME,MID				
9	8102-142	2	CAPSCREW,HH,5/16-18x3.25,GD8				
10	8051-242	2	WASHER,SPRING LOCK,5/16,ZN				
11	8050-262	2	WASHER,WROUGHT,5/16,STD,ZN				
12	8040-186	2	NUT,NYLOCK 8-32				
13	2030-272	1	PLATE BACKING GAUGES				
14	2045-502	1	METER HOUR				
15	0304-028	1	SWITCH,IGNITION,RC				
16	0310-138	6	PLUG				
17	2045-725	1	SWITCH 2 POSITION LOCKING (OPTIONAL)				
18	2045-477	1	SWITCH SELF LEVELER				
19	0200-252	1	SWITCH,3 POSITION,LOCKING				
20	2045-432	1	KEY IGNITION				
21	2045-792	1	COVER KEY IGNITION				
22	0304-551	1	RING,KEY				
23	0090-038	2	SCREW MACHINE PH 8-32 x .625 SS				
24	2030-244	1	GAUGE WARNING INDICATION				
25	4010-014	1	GAUGE FUEL				
26	4010-013	1	GAUGE,ENGINE,TEMP (OPTIONAL)				
27	4010-017	1	TACHOMETER (OPTIONAL)				
28	0310-133	1	SWITCH,BEACON				
29	0304-123	1	SWITCH,ON/OFF,WIPER				
30	0310-128	1	SWITCH,HEATER				
31	0310-126	1	SWITCH,LIGHT				
32	0310-136	4	FRAME,END				

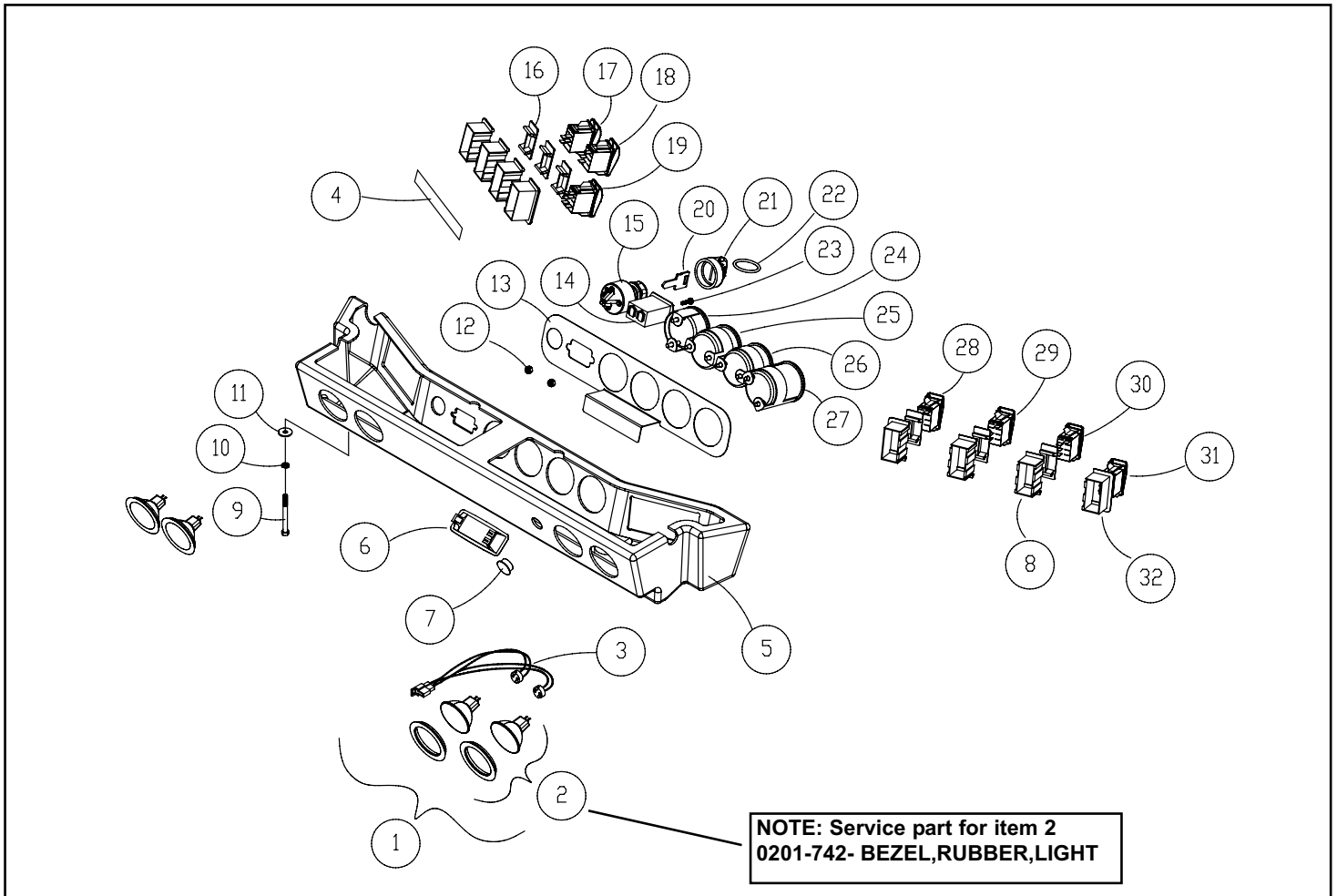

LIGHT BAR ASSEMBLY

RT- 60 00668 - 04102
R190T 00512 - 04102

Chapter 4

REF. NO.	PART NUMBER	QTY.	DESCRIPTION	REF. NO.	PART NUMBER	QTY.	DESCRIPTION
1	2045-755	4	KIT LIGHTS 35W W/ HARNESS				
2	2045-756	4	LIGHT 35W W/BEZEL				
3	0201-595	2	HARNESS,LIGHT,DOUBLE				
4	2030-331	1	DECAL DASH PANEL				
5	2030-241	1	CONSOLE MACHINED				
6	2030-245	1	LIGHT DOME				
7	0304-411	1	PLUG, HOLE, 3/4", PLASTIC				
8	0310-137	4	FRAME,MID				
9	8102-142	2	CAPSCREW,HH,5/16-18x3.25,GD8				
10	8051-242	2	WASHER,SPRING LOCK,5/16,ZN				
11	8050-262	2	WASHER,WROUGHT,5/16,STD,ZN				
12	8040-186	2	NUT,NYLOCK 8-32				
13	2030-272	1	PLATE BACKING GAUGES				
14	2045-502	1	METER HOUR				
15	0304-028	1	SWITCH,IGNITION,RC				
16	0310-138	6	PLUG				
17	2045-725	1	SWITCH 2 POSITION LOCKING (OPTIONAL)				
18	2045-477	1	SWITCH SELF LEVELER				
19	0200-252	1	SWITCH,3 POSITION,LOCKING				
20	2045-432	1	KEY IGNITION				
21	2045-792	1	COVER KEY IGNITION				
22	0304-551	1	RING,KEY				
23	0090-038	2	SCREW MACHINE PH 8-32 x .625 SS				
24	4030-129	1	GAUGE WARNING INDICATION				
25	4030-127	1	GAUGE FUEL				
26	2030-303	1	PLUG FINISHING 2" HEYCO 3050				
27	4030-128	1	TACHOMETER (OPTIONAL)				
28	0310-133	1	SWITCH,BEACON				
29	0304-123	1	SWITCH,ON/OFF,WIPER				
30	0310-128	1	SWITCH,HEATER				
31	0310-126	1	SWITCH,LIGHT				
32	0310-136	4	FRAME,END				
33	2075-749	1	INDICATOR RABBIT/GLOW PLUG				

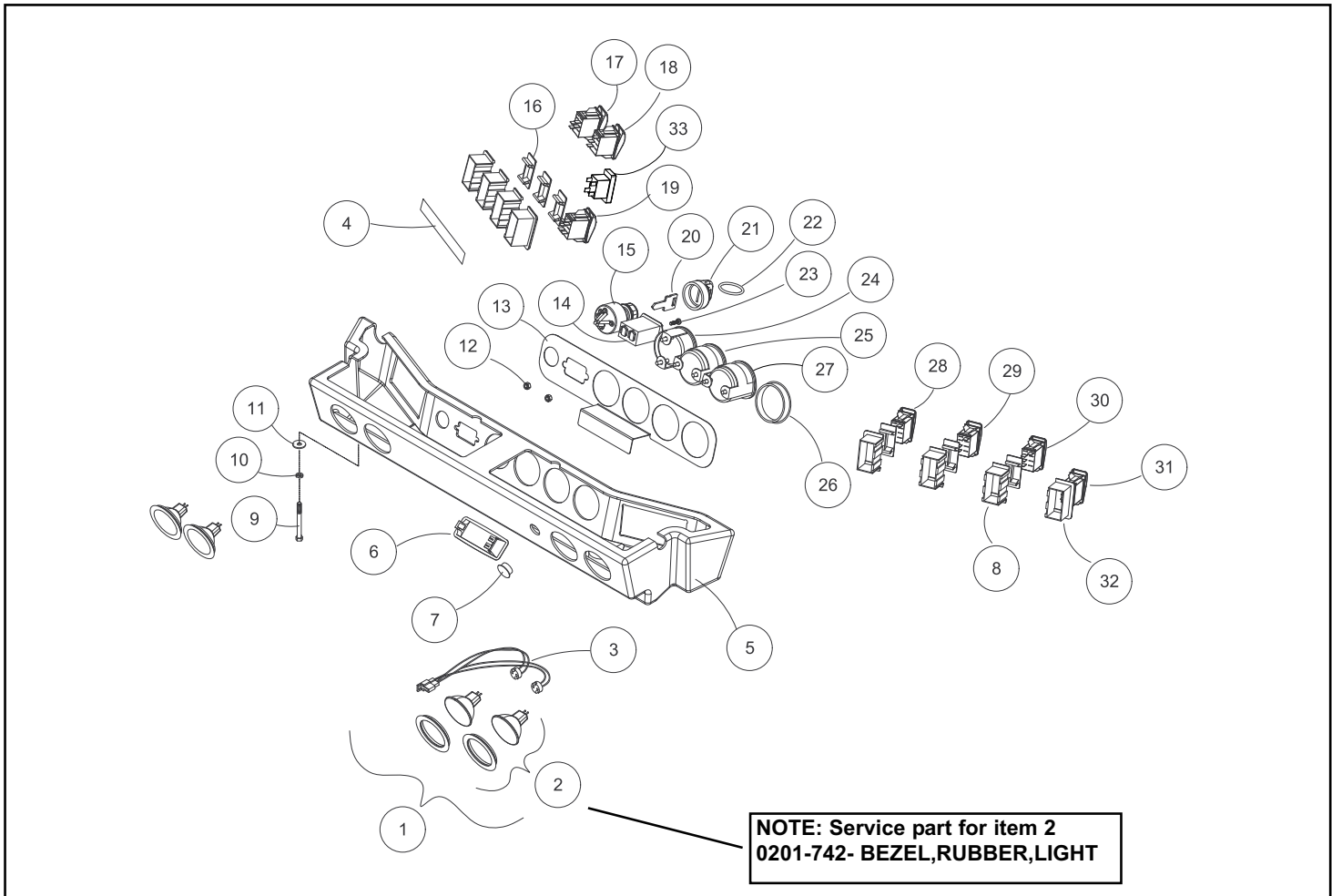

LIGHT BAR ASSEMBLY

RT- 60 valid from 04103
R190T valid from 04103

Section 4

REF. NO.	PART NUMBER	QTY.	DESCRIPTION	REF. NO.	PART NUMBER	QTY.	DESCRIPTION
1	2045-755	4	KIT LIGHTS 35W W/ HARNESS				
2	2045-756	4	LIGHT 35W W/BEZEL				
3	0201-595	2	HARNESS,LIGHT,DOUBLE				
4	2030-331	1	DECAL DASH PANEL				
5	2030-241	1	CONSOLE MACHINED				
6	2030-245	1	LIGHT DOME				
7	0304-411	1	PLUG, HOLE, 3/4", PLASTIC				
8	0310-137	4	FRAME,MID				
9	8102-142	2	CAPSCREW,HH,5/16-18x3.25,GD8				
10	8051-242	2	WASHER,SPRING LOCK,5/16,ZN				
11	8050-262	2	WASHER,WROUGHT,5/16,STD,ZN				
12	8040-186	2	NUT,NYLOCK 8-32				
13	2075-749	1	INDICATOR RABBIT/GLOW PLUG				
14	2045-502	1	METER HOUR				
15	0304-028	1	SWITCH,IGNITION,RC				
16	0310-138	6	PLUG				
17	2045-725	1	SWITCH 2 POSITION LOCKING (ORTIONAL)				
18	2045-477	1	SWITCH SELF LEVELER				
19	0200-252	1	SWITCH,3 POSITION,LOCKING				
20	2045-432	1	KEY IGNITION				
21	2045-792	1	COVER KEY IGNITION				
22	0304-551	1	RING,KEY				
23	0090-038	2	SCREW MACHINE PH 8-32 x .625 SS				
24	4030-129	1	GAUGE WARNING INDICATION				
25	4030-227	1	GAUGE, 2" FUEL, MAXIMATECC				
26	2030-303	1	PLUG FINISHING 2" HEYCO 3050				
27	4030-228	1	GAUGE, 2" TACHOMETER, MAXIMATECC				
28	0310-133	1	SWITCH,BEACON				
29	0304-123	1	SWITCH,ON/OFF,WIPER				
30	0310-128	1	SWITCH,HEATER				
31	0310-126	1	SWITCH,LIGHT				
32	0310-136	4	FRAME,END				

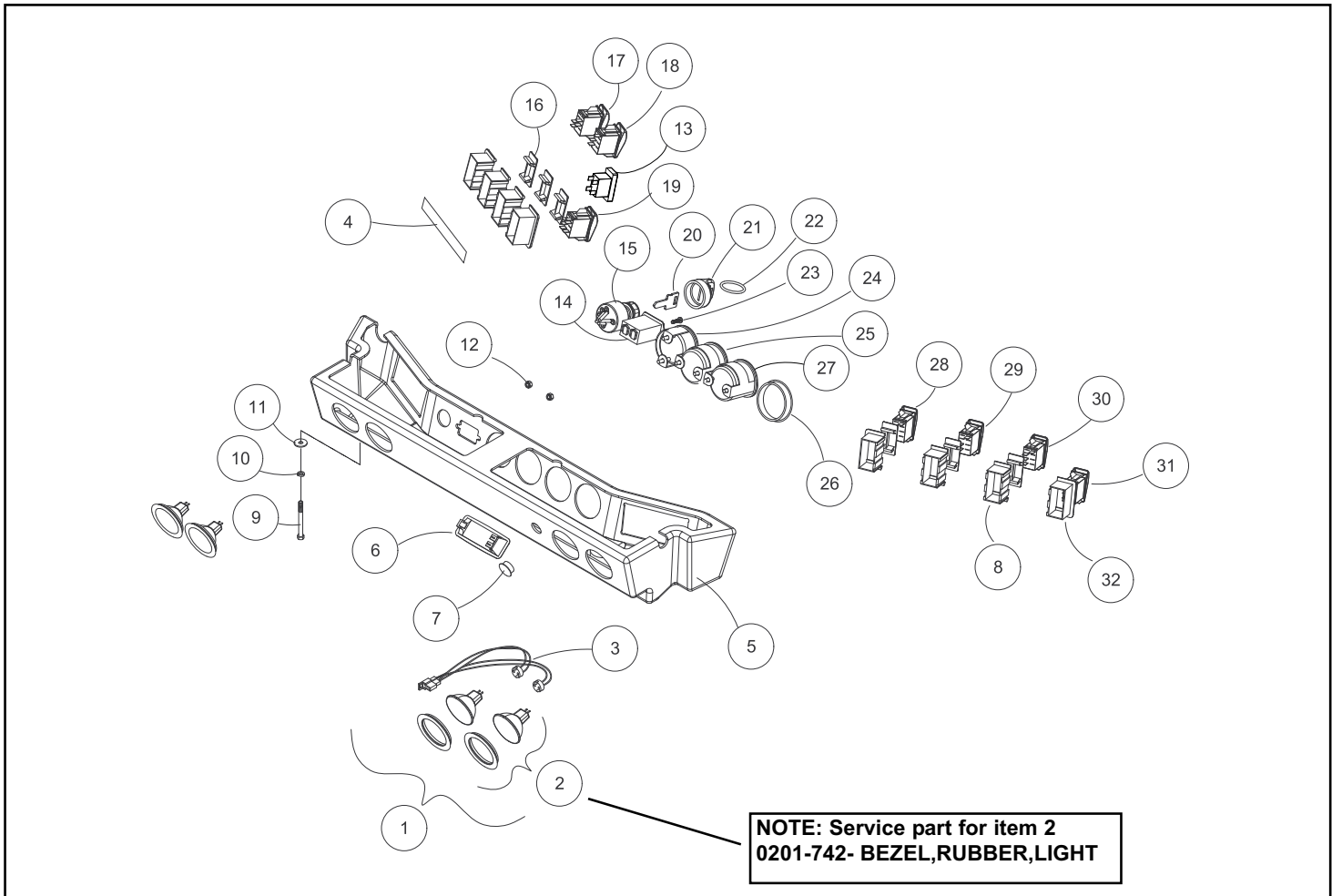

FUSE PANEL ASSEMBLY

RT- 60 valid from - 00600
R190T valid from - 00300

Chapter 4

REF. NO.	PART NUMBER	QTY.	DESCRIPTION	REF. NO.	PART NUMBER	QTY.	DESCRIPTION
1	-----	1	HARNES MAIN --SEE HARNESES ON PAGE III				
2	0310-807	2	RELAY,MINI, 35 AMP				
3	0310-805	1	FUSE,MAXI, 80 AMP				
4	0304-519	6	RELAY,PLUG,GLOW				
5	0310-800	1	FUSE,MAXI,20 AMP				
6	0310-803	2	FUSE,MAXI, 50 AMP				
7	0310-802	2	FUSE,MAXI, 40 AMP				
8	0310-794	5	FUSE,MINI, 5 AMP				
9	0310-795	6	FUSE,MINI,10 AMP				
10	0310-797	2	FUSE,MINI,20 AMP				
11	0310-806	4	RELAY,MICRO, 20 AMP				
12	0310-811	1	DIODE, 3 AMP				
13	0310-796	1	FUSE,MINI,15 AMP				
14	0310-801	1	FUSE,MAXI, 30 AMP				
15	0310-798	1	FUSE,MINI,25 AMP				
16	2030-196	1	COVER,PANEL,FUSE,W/DECALS,RC60				
17	0200-510	1	RESISTOR,330HM/3WATT,OHMITE43F				
18	0310-799	1	FUSE,MINII, 30 AMP				
19	0310-793	1	FUSE,MINI,2 AMP				

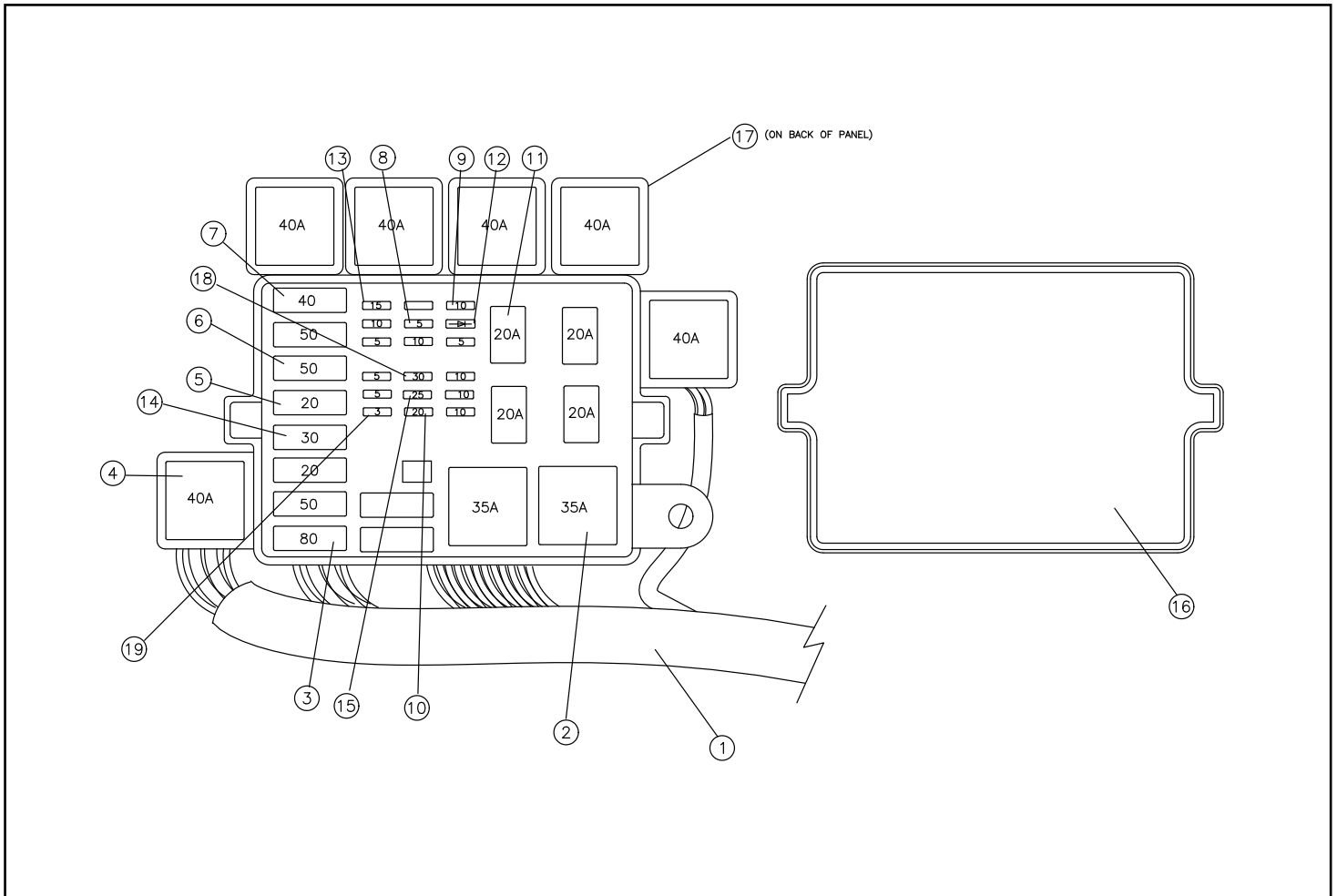

Chapter 5

Undercarriage

5-1 Torsion Axle Assembly

R190T Serial # 00300 - 00393.5-1A
RT-60 Serial # 00600 - 00622.5-1B
R190T Serial # 00394 - 00460.5-1B
RT-60 Serial # valid from - 00623.5-1C
R190T Serial # valid from - 00461.5-1C

5-2 Undercarriage Assembly RT

RT-60 Serial # 00600 - 00622.	5-2A
R190T Serial # 00300 - 00460.	5-2A
RT-60 Serial # valid from - 00623.5-2B
R190T Serial # valid from - 00461.5-2B

5-3 Undercarriage Assembly LT

RT-60 Serial # 00600 - 00622.	5-3A
R190T Serial # 00300 - 00460.	5-3A
RT-60 Serial # valid from - 00623.5-3B
R190T Serial # valid from - 00461.5-3B

5-4 Track Installation Tool

RT-60 Serial # valid from - 00600.5-4A
R190T Serial # valid from - 00300.5-4A

* **Parts manuals are updated on a regular basis. Always refer to the current online version to ensure you have the most up to date information prior to ordering parts.**

NOTE: Ordering parts that are painted requires a specific part number format. Please refer to page II of this manual for paint code and ordering information.

TORSION AXLE ASSEMBLY

R190T 00300 - 00393

Chapter 5

REF. NO.	PART NUMBER	QTY.	DESCRIPTION	REF. NO.	PART NUMBER	QTY.	DESCRIPTION
1	0702-441	2	TRACK,15 x 165,9				
2	2030-807	1	AXLE TORSION FRONT				
3	2030-649	1	AXLE TORSION REAR				
4	8102-586	16	CAPSCREW,HH,5/8-11X1.75ZN,GD8				
5	8040-726	16	NUT,HEX,NYLOCK,5/8-11 UNC,ZN				
6	8050-408	32	WASHER,FLAT,5/8,THICK				
7	8051-431	16	WASHER,SPRING LOCK,5/8,ZN				
8	0200-341	4	CAPSCREW,HH,3/4-16x2.25,GD8				
9	8051-440	4	WASHER,SPRING LOCK,3/4,ZN				
10	0200-287	4	WASHER,1/2"THICK				
11	0702-503	4	TUBE SPACER				

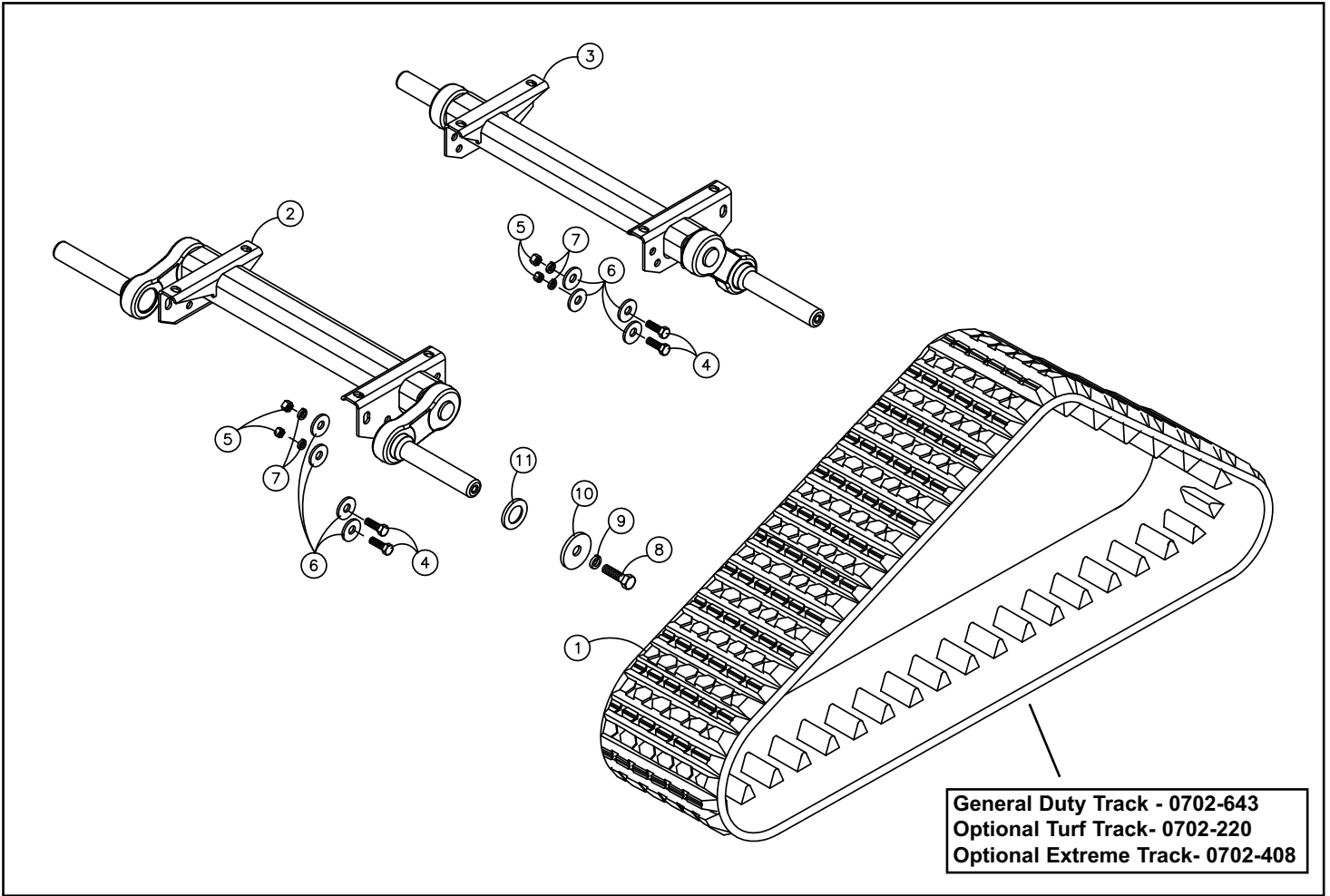

TORSION AXLE ASSEMBLY

RT- 60 valid from - 00623

R190T valid from - 00461

Chapter 5

REF. NO.	PART NUMBER	QTY.	DESCRIPTION	REF. NO.	PART NUMBER	QTY.	DESCRIPTION
1	0702-441	2	TRACK,15 x 165,9				
2	2030-846	1	AXLE,TORSION,FRONT				
3	2030-649	1	AXLE,TORSION,REAR				
4	8102-586	16	CAPSCREW,HH,5/8-11X1.75ZN,GD8				
5	8040-726	16	NUT,HEX,NYLOCK,5/8-11 UNC,ZN				
6	8050-408	32	WASHER,FLAT,5/8,THICK				
7	8051-431	16	WASHER,SPRING LOCK,5/8,ZN				
8	0200-341	4	CAPSCREW,HH,3/4-16x2.25,GD8				
9	8051-440	4	WASHER,SPRING LOCK,3/4,ZN				
10	0200-287	4	WASHER,1/2"THICK				
11	0702-503	4	TUBE SPACER				
12	2035-249	8	SPACER 1.874X2.500X.125				
13	2030-738	4	WASHER 1.5 x .625 x .25				

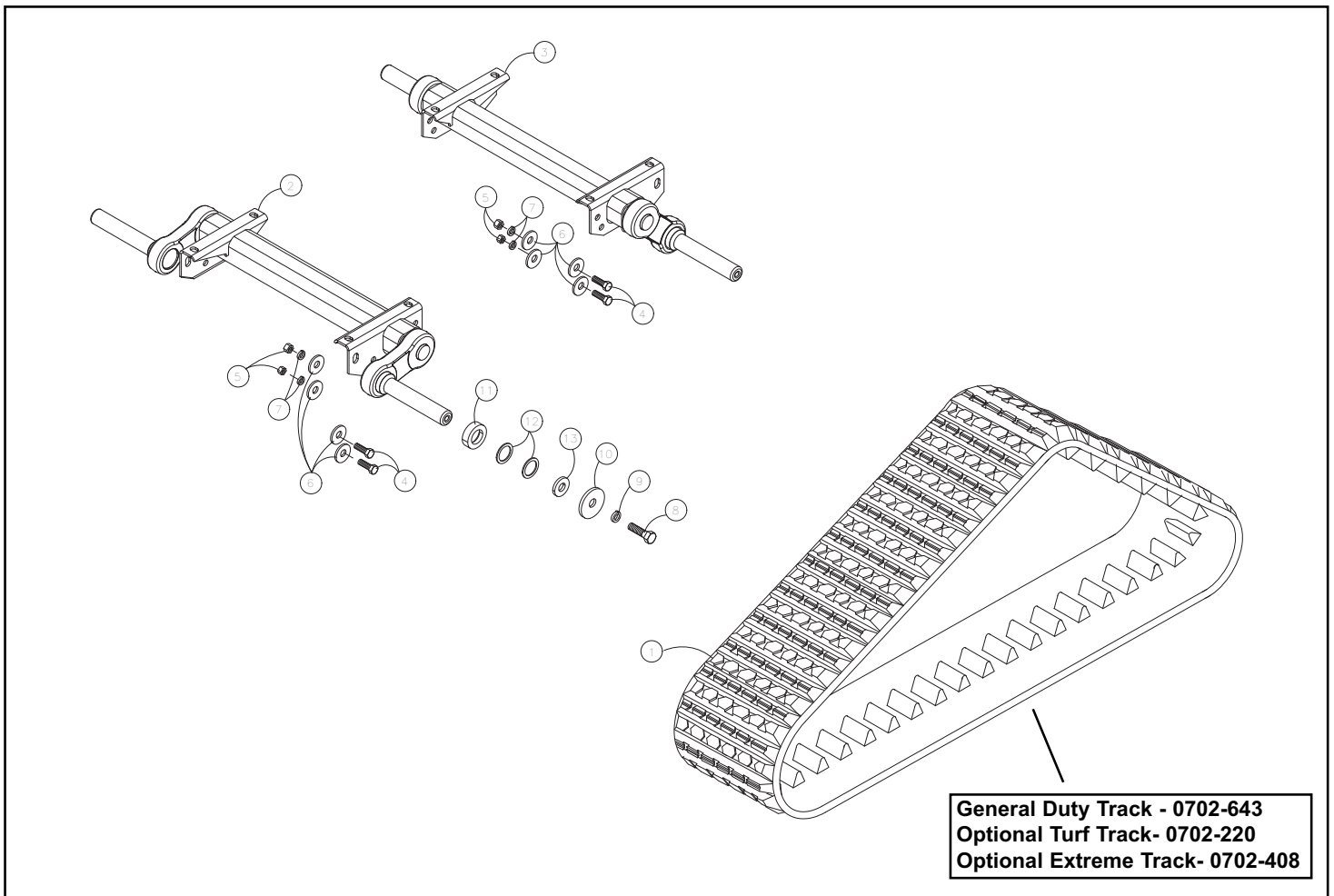

General Duty Track - 0702-643
 Optional Turf Track - 0702-220
 Optional Extreme Track - 0702-408

UNDERCARRIAGE ASSEMBLY RT

RT- 60 00600 - 00622
R190T 00300 - 00460

Chapter 5

REF. NO.	PART NUMBER	QTY.	DESCRIPTION	REF. NO.	PART NUMBER	QTY.	DESCRIPTION
1	0702-317	6	WLMT AXLE WHEEL	41	8040-606	3	NUT,HEX,NYLOCK,1/2-13 UNC,ZN
2	2035-596	12	O-RING 1/16 x 1.375 x 1.5 NITRILE, -028	42	8102-406	3	CAPSCREW,HH,1/2-13UNCx1.75,GD8
3	0702-367	12	WLMT RETAINER 53MM	43	8043-806	1	NUT,HEX,1-8 UNC,STEEL LOCK,ZN
4	2035-438	12	ASSY, SEAL, 53 MM	44	8102-685	1	CAPSCREW,HH 3/4-10UNCx 4.5 GD8
5	2035-391	12	RETAINER INNER 53MM	45	0702-551	1	WLMT RAIL ALPHA BOLT-ON
6	0702-509	24	BEARING CONE	46	2035-308	1	PIN,TENSIONER,THREADED
7	0702-508	24	BEARING CUP	47	2035-214	4	BUSHING,SPRING,1.75x2.00x2.50
8	0702-569	2	ASSY HUB 14" 8 BOLT	48	0702-409	2	PLATE JOINT SWING
9	2035-479	12	PLUG 1/8" NRT HEX CS	49	0090-317	2	NUT HEX 1.25-7 UNC JAM ZINC
10	0702-368	12	SEAL LIP	50	2035-471	1	CAPSCREW SOC HD 3/8-16 x 1
11	0702-264	2	WHEEL 14" W/PLATE	51	0702-472	1	ASSY TENSIONER
12	0702-371	10	SNAP RING .093 x .3.25	52	0304-722	1	NUT,HEX,JAM,LOCKING,3/4-10UNC,
13	2035-644	10	WHEEL 10" ALPHA BOLT ON	53	8102-586	12	CAPSCREW,HH,5/8-11X1.75ZN,GD8
14	0702-560	10	ASSY HUB 10" 8 BOLT	54	8051-431	12	WASHER,SPRING LOCK,5/8,ZN
15	0702-605	10	ASSEMBLY HUB 10" / WHEEL (EXCLUDES: 12,19,20,21)	55	0310-345	1	ADAPTER,8MFFOR--8MB
16	0090-136	96	WASHER HARD 1.0 X .531 X .197	56	0201-309	1	ADAPTER,FS6400-04-06-0
17	2035-659	96	CAPSCREW HH 1/2-13 x 1.375 GR8	57	0310-313	2	ADAPTER,12MFFOR-12MB
18	0700-144	4	RING,SNAP,INT,85mm	58	0702-641	1	MOTOR HYD
19	0702-644	12	CAP, HUB	59	0702-615	2	ASSEMBLY HUB 14" W/RUBBER WHEEL
20	2035-595	12	NUT HEX JAM LOCKING 7/8-9 UNC	60	8102-890	1	CAPSCREW,HH,1.0 x 8UNC x 10.0,
21	0702-364	12	WASHER HARD .25 x 2.125 x .935	61	0702-507	1	WLMT TENSIONER THREADED
22	8051-332	4	WASHER,SPRING LOCK,1/2,ZN	62	0702-473	1	WLMT TENSIONER TUBE
23	8102-404	4	CAPSCREW,HH 1/2-13UNCx1.25 GD8	63	0090-262	1	WASHER SAFETY S33-1.25"
24	0702-294	1	END CAP 3.346 x .295	64	0702-196	1	ASSY,SPROCKET ALPHA/RC60/RC50
25	0700-145	1	RING,SNAP,EXT,45mm	65	0702-305	1	SUB-ASSY HSG BEARING
26	0702-024	1	WLMT,PLATE,BEARING	66	0702-413	1	AXLE SWING JOINT
27	0702-324	1	BEARING (6209)	67	0702-410	1	TUBE MNT AXLE
28	2035-134	1	SEAL 1.975 x 3.370 x .763				
29	0702-295	1	RETAINER SEAL				
30	0702-293	1	HOUSING BEARING				
31	0702-292	1	FLANGE BEARING				
32	0702-230	1	SPROCKET,CAST,MACHINED				
33	0700-124	12	NUT,TOPLock,1/2-13UNC,ZN,GD8				
34	0200-003	12	TUBE,COVER				
35	0200-004	12	TUBE,INNER				
36	0702-048	1	RING,SPROCKET,ALPHA				
37	8102-423	12	CAPSCREW,HH,1/2-13UNCx7.25,GD8				
38	0210-001	12	STUD,WHEEL,M14x1.5 174862				
39	0200-282	12	NUT,FLANGE,M14x1.5				
40	0702-225	1	TABLE,MACHINED,RH				

For kit information, please see page 10-1A

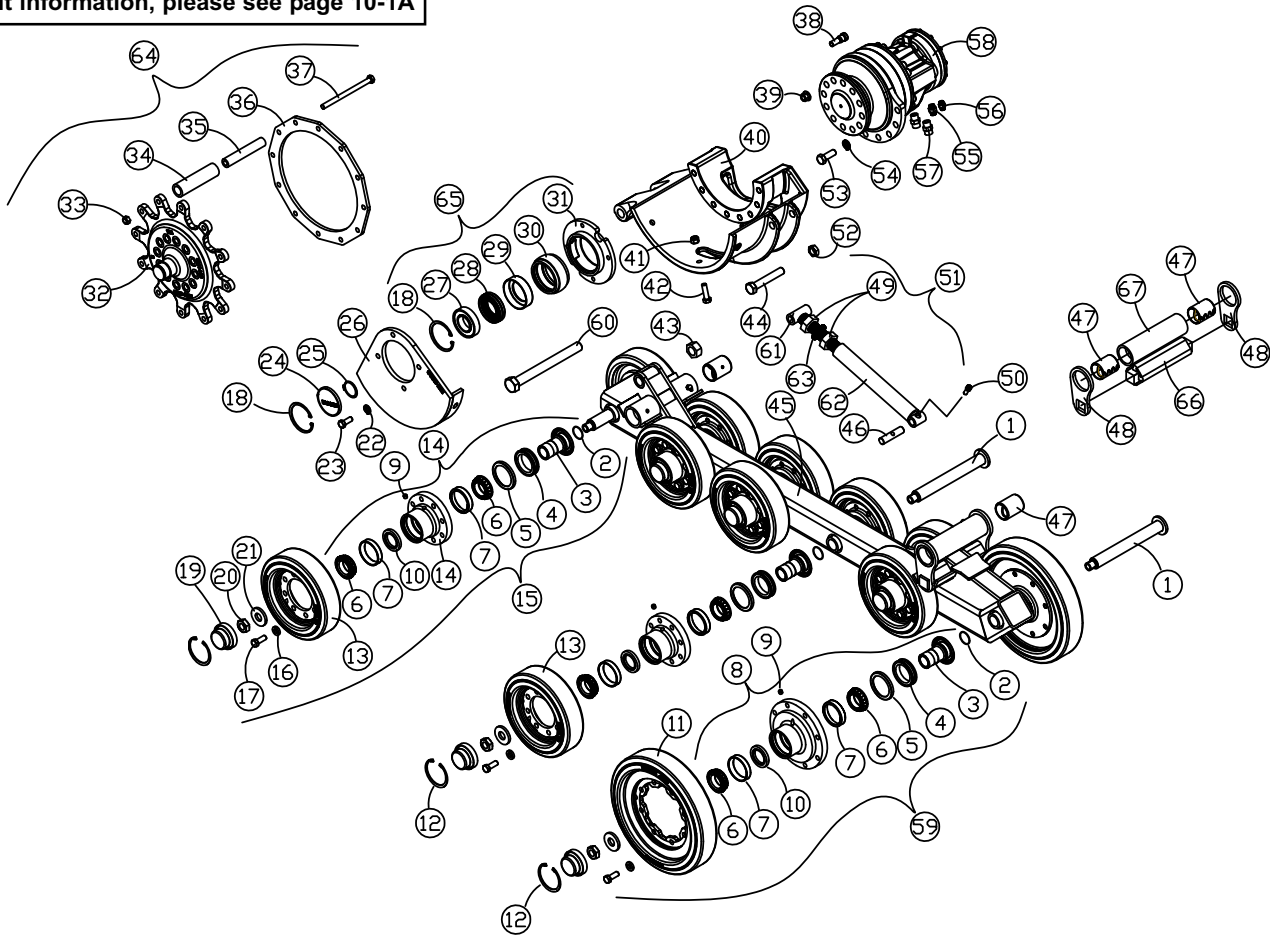

UNDERCARRIAGE ASSEMBLY RT

RT- 60 valid from - 00623
R190T valid from - 00461

Chapter 5

REF. NO.	PART NUMBER	QTY.	DESCRIPTION	REF. NO.	PART NUMBER	QTY.	DESCRIPTION
1	2035-197	20	CAPSCREW,SOC HD,M16X2.0,45MM	41	0702-361	10	HUB 10" 8 BOLT MACHINED
2	0700-287	20	WASHER,16mmX30mmX5mm	42	0702-605	10	ASSEMBLY HUB 10" W/RUBBER WHEEL
3	0702-588	1	SPROCKET .625" OFFSET	43	2035-644	10	WHEEL 10" ALPHA BOLT ON
4	0700-124	12	NUT,TOPLock,1/2-13UNC,ZN,GD8	44	0702-450	12	TUBE,INNER
5	2035-597	12	WASHER WROUGHT .531 x .886 x 0118 HARD ZN	45	2035-596	12	O-RING 1/16 x 1.375 x 1.5 NITRILE, -028
6	0702-451	12	TOOTH DRIVE SPROCKET 5.625"	46	0702-483	2	PLATE TORSION
7	2035-120	1	RING,SPROCKET,BONFIG	47	0702-413	1	AXLE SWING JOINT
8	2035-617	12	BOLT CARRIAGE 1/2-13 UNC x 7.5" GR8	48	0702-410	1	TUBE MNT AXLE
9	8102-890	1	CAPSCREW,HH,1.0 x 8UNC x 10.0,GD8,ZN	49	0702-578	1	MOTOR HYD BONFIG SAUER 2 SPD
10	0702-338	1	TABLE RH ALPHA T3 MACHINED				
11	8043-806	1	NUT,HEX,1-8 UNC,STEEL LOCK,ZN				
12	8040-786	1	NUT,HEX,NYLOCK,3/4-10 UNC,ZN				
13	0304-408	1	CAPSCREW,HH,3/4-10UNC3.75,GD8,				
14	2035-448	1	CLEVIS END TENSIONER MACHINED				
15	0090-317	2	NUT HEX 1.25-7 UNC JAM ZINC				
16	0090-262	1	WASHER SAFETY S33-1.25"				
17	0702-473	1	WLMT TENSIONER TUBE				
18	2035-471	1	CAPSCREW SOC HD 3/8-16 x 1				
19	2035-308	1	PIN,TENSIONER,THREADED				
20	2035-214	4	BUSHING,SPRING,1.75x2x2.50				
21	0304-427	4	FITTING,GREASE,1/8 NPT x 45^				
22	0702-488	1	BUSHING SPRING 1.25x1x2.75				
23	0702-551	1	WLMT RAIL ALPHA				
24	0702-388	2	AXLE 1.25" ALPHA				
25	0702-367	12	WLMT RETAINER 53MM				
26	2035-438	12	ASSY, SEAL, 53 MM				
27	2035-391	12	RETAINER INNER 53MM				
28	0702-509	24	BEARING CONE LM5013349 PEER				
29	0702-508	24	BEARING CUP				
30	0702-370	2	HUB 14" 8 BOLT MACHINED				
31	2035-479	12	PLUG 1/8" NPT HEX CS				
32	0702-368	12	SEAL LIP				
33	0702-364	12	WASHER HARD .25 x 2.125 x .935				
34	2035-595	12	NUT HEX JAM LOCK 7/8-9 UNC GR C				
35	0702-644	12	CAP, HUB				
36	0702-371	12	SNAP RING .093 x .3.25				
37	0702-264	2	WHEEL 14" W/PLATE				
38	0090-136	96	WASHER HARD 1.0 X .531 X .197				
39	2035-659	96	CAPSCREW HH 1/2-13 x 1.375 GR8				
40	0702-615	2	ASSEMBLY HUB 14" W/RUBBER WHEEL				

ASV P/N: 0702-560 includes items: 25-29, 31-32 & 41
ASV P/N: 0702-569 includes items: 25-32

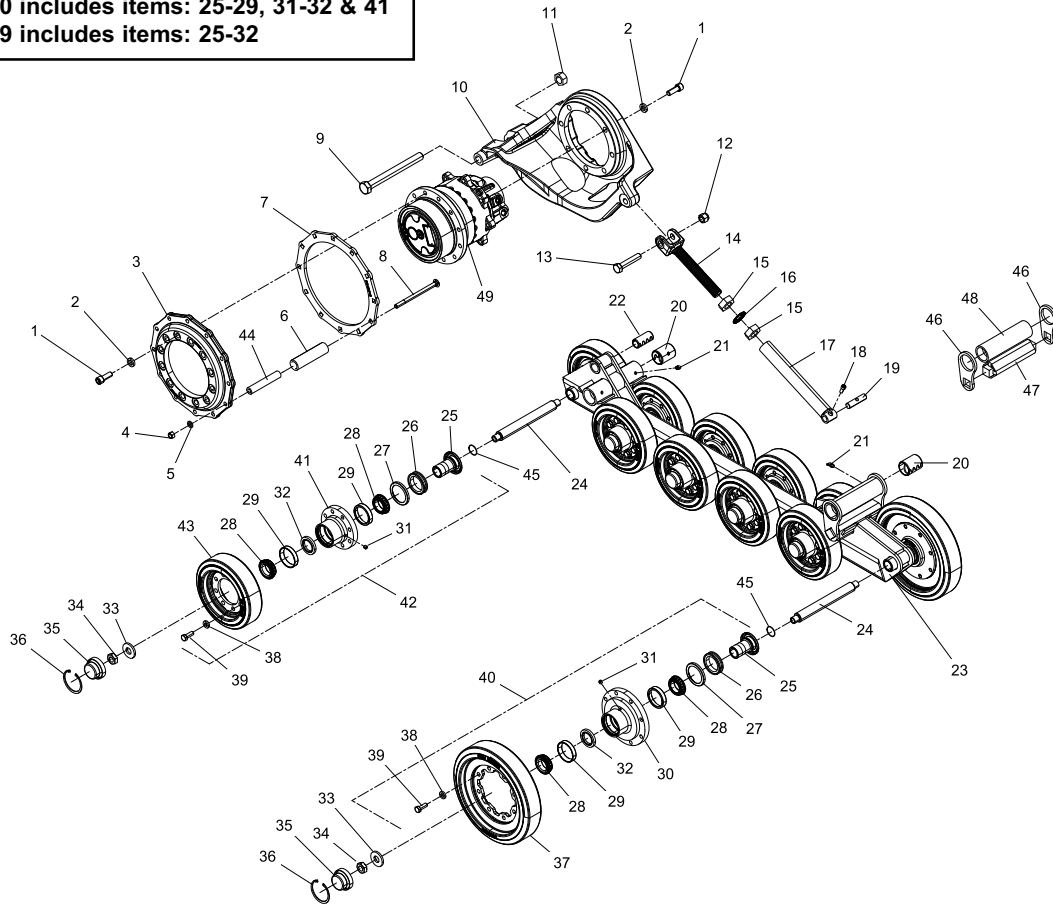

UNDERCARRIAGE ASSEMBLY LT

RT- 60 00600 - 00622
R190T 00300 - 00460

Chapter 5

REF. NO.	PART NUMBER	QTY.	DESCRIPTION	REF. NO.	PART NUMBER	QTY.	DESCRIPTION
1	0702-317	6	WLMT AXLE WHEEL	41	8040-606	3	NUT,HEX,NYLOCK,1/2-13 UNC,ZN
2	2035-596	12	O-RING 1/16 x 1.375 x 1.5 NITRILE, -.028	42	8102-406	3	CAPSCREW,HH,1/2-13UNCx1.75,GD8
3	0702-367	12	WLMT RETAINER 53MM	43	8043-806	1	NUT,HEX,1-8 UNC,STEEL LOCK,ZN
4	2035-438	12	ASSY, SEAL, 53 MM	44	8102-685	1	CAPSCREW,HH 3/4-10UNCx 4.5 GD8
5	2035-391	12	RETAINER INNER 53MM	45	0702-551	1	WLMT RAIL ALPHA BOLT-ON
6	0702-509	24	BEARING CONE	46	2035-308	1	PIN,TENSIONER,THREADED
7	0702-508	24	BEARING CUP	47	2035-214	4	BUSHING,SPRING,1.75x2.00x2.50
8	0702-569	2	ASSY HUB 14" 8 BOLT	48	0702-409	2	PLATE JOINT SWING
9	2035-479	12	PLUG 1/8" NPT HEX CS	49	0090-317	2	NUT HEX 1.25-7 UNC JAM ZINC
10	0702-368	12	SEAL LIP	50	2035-471	1	CAPSCREW SOC HD 3/8-16 x 1
11	0702-264	2	WHEEL 14" W/PLATE	51	0702-472	1	ASSY TENSIONER
12	0702-371	10	SNAP RING .093 x .3.25	52	0304-722	1	NUT,HEX,JAM,LOCKING,3/4-10UNC,
13	2035-644	10	WHEEL 10" ALPHA BOLT ON	53	8102-586	12	CAPSCREW,HH,5/8-11X1.75ZN,GD8
14	0702-560	10	ASSY HUB 10" 8 BOLT	54	8051-431	12	WASHER,SPRING LOCK,5/8,ZN
15	0702-605	10	ASSEMBLY HUB 10" / WHEEL (EXCLUDES: 12,19,20,21)	55	0310-345	1	ADAPTER,8MFFOR--8MB
16	0090-136	96	WASHER HARD 1.0 X .531 X .197	56	0201-309	1	ADAPTER,FS6400-04-06-0
17	2035-659	96	CAPSCREW HH 1/2-13 x 1.375 GR8	57	0310-313	2	ADAPTER,12MFFOR-12MB
18	0700-144	4	RING,SNAP,INT,85mm	58	0702-641	1	MOTOR HYD
19	0702-644	12	CAP, HUB	59	0702-615	2	ASSEMBLY HUB 14" W/RUBBER WHEEL
20	2035-595	12	NUT HEX JAM LOCKING 7/8-9 UNC	60	8102-890	1	CAPSCREW,HH,1.0 x 8UNC x 10.0,
21	0702-364	12	WASHER HARD .25 x 2.125 x .935	61	0702-507	1	WLMT TENSIONER THREADED
22	8051-332	4	WASHER,SPRING LOCK,1/2,ZN	62	0702-473	1	WLMT TENSIONER TUBE
23	8102-404	4	CAPSCREW,HH 1/2-13UNCx1.25 GD8	63	0090-262	1	WASHER SAFETY S33-1.25"
24	0702-294	1	END CAP 3.346 x .295	64	0702-196	1	ASSY,SPROCKET ALPHA/RC60/RC50
25	0700-145	1	RING,SNAP,EXT,45mm	65	0702-305	1	SUB-ASSY HSG BEARING
26	0702-024	1	WLMT,PLATE,BEARING	66	0702-413	1	AXLE SWING JOINT
27	0702-324	1	BEARING (6209)	67	0702-410	1	TUBE MNT AXLE
28	2035-134	1	SEAL 1.975 x 3.370 x .763				
29	0702-295	1	RETAINER SEAL				
30	0702-293	1	HOUSING BEARING				
31	0702-292	1	FLANGE BEARING				
32	0702-230	1	SPROCKET,CAST,MACHINED				
33	0700-124	12	NUT,TOPLock,1/2-13UNC,ZN,GD8				
34	0200-003	12	TUBE,COVER				
35	0200-004	12	TUBE,INNER				
36	0702-048	1	RING,SPROCKET,ALPHA				
37	8102-423	12	CAPSCREW,HH,1/2-13UNCx7.25,GD8				
38	0210-001	12	STUD,WHEEL,M14x1.5 174862				
39	0200-282	12	NUT,FLANGE,M14x1.5				
40	0702-226	1	TABLE,MACHINED,LH				

For kit information, please see page 10-1A

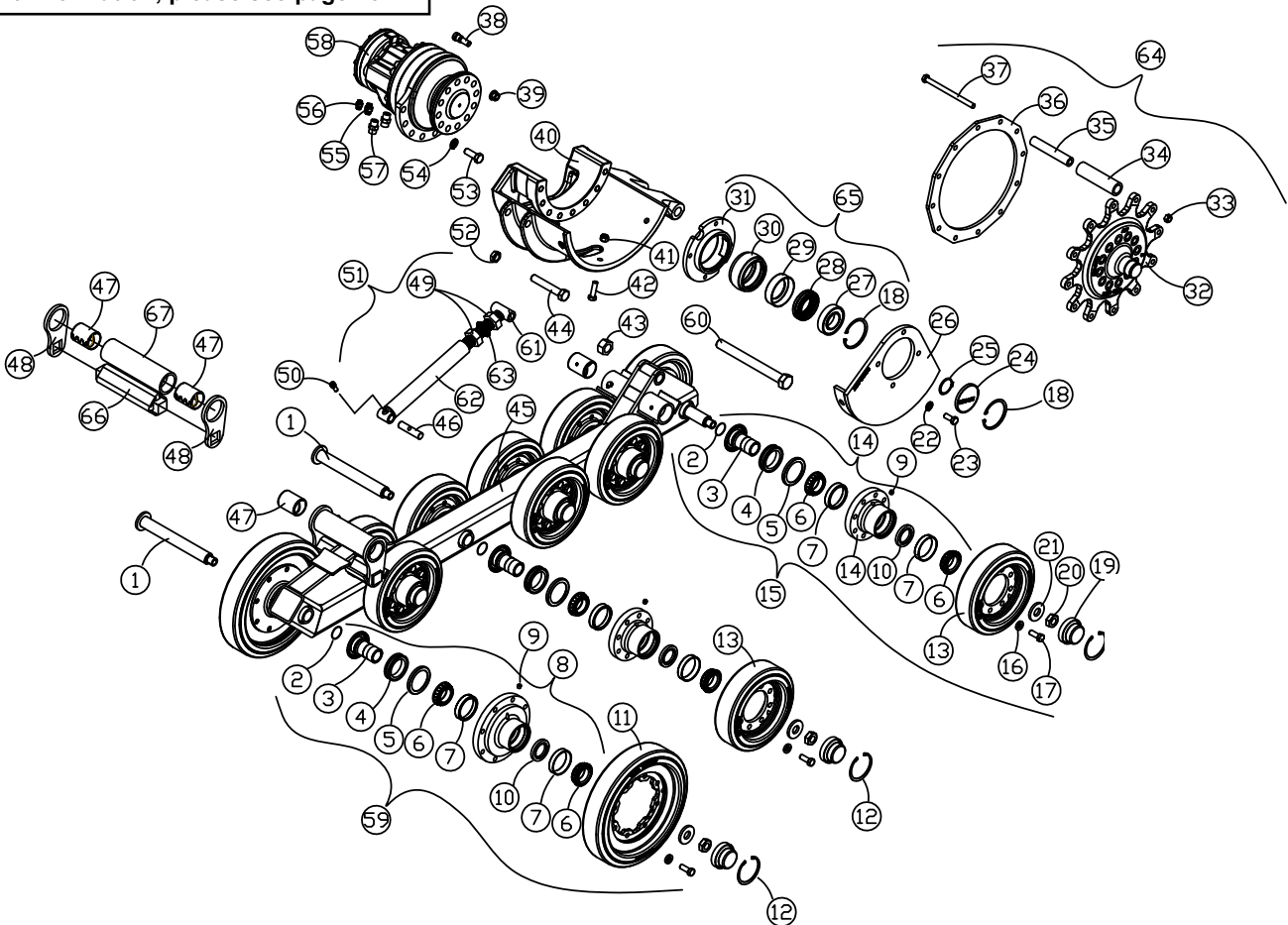

UNDERCARRIAGE ASSEMBLY LT

RT- 60 valid from - 00623
R190T valid from - 00461

Chapter 5

REF. NO.	PART NUMBER	QTY.	DESCRIPTION	REF. NO.	PART NUMBER	QTY.	DESCRIPTION
1	2035-197	20	CAPSCREW,SOC HD,M16X2.0,45MM	41	0702-361	10	HUB 10" 8 BOLT MACHINED
2	0700-287	20	WASHER,16mmX30mmX5mm	42	0702-605	10	ASSEMBLY HUB 10" W/RUBBER WHEEL
3	0702-588	1	SPROCKET .625" OFFSET	43	2035-644	10	WHEEL 10" ALPHA BOLT ON
4	0700-124	12	NUT,TOPLock,1/2-13UNC,ZN,GD8	44	0702-450	12	TUBE,INNER
5	2035-597	12	WASHER WROUGHT .531 x .886 x 0118 HARD ZN	45	2035-596	12	O-RING 1/16 x 1.375 x 1.5 NITRILE, -028
6	0702-451	12	TOOTH DRIVE SPROCKET 5.625"	46	0702-483	2	PLATE TORSION
7	2035-120	1	RING,SPROCKET,BONFIG	47	0702-413	1	AXLE SWING JOINT
8	2035-617	12	BOLT CARRIAGE 1/2-13 UNC x 7.5" GR8	48	0702-410	1	TUBE MNT AXLE
9	8102-890	1	CAPSCREW,HH,1.0 x 8UNC x 10.0,GD8,ZN	49	0702-578	1	MOTOR HYD BONFIG SAUER 2 SPD
10	0702-226	1	TABLE LH ALPHA T3 MACHINED				
11	8043-806	1	NUT,HEX,1-8 UNC,STEEL LOCK,ZN				
12	8040-786	1	NUT,HEX,NYLOCK,3/4-10 UNC,ZN				
13	0304-408	1	CAPSCREW,HH,3/4-10UNC3.75,GD8,				
14	2035-448	1	CLEVIS END TENSIONER MACHINED				
15	0090-317	2	NUT HEX 1.25-7 UNC JAM ZINC				
16	0090-262	1	WASHER SAFETY S33-1.25"				
17	0702-473	1	WLMT TENSIONER TUBE				
18	2035-471	1	CAPSCREW SOC HD 3/8-16 x 1				
19	2035-308	1	PIN,TENSIONER,THREADED				
20	2035-214	4	BUSHING,SPRING,1.75x2x2.50				
21	0304-427	4	FITTING,GREASE,1/8 NPT x 45^				
22	0702-488	1	BUSHING SPRING 1.25x1x2.75				
23	0702-551	1	WLMT RAIL ALPHA				
24	0702-388	2	AXLE 1.25" ALPHA				
25	0702-367	12	WLMT RETAINER 53MM				
26	2035-438	12	ASSY, SEAL, 53 MM				
27	2035-391	12	RETAINER INNER 53MM				
28	0702-509	24	BEARING CONE LM5013349 PEER				
29	0702-508	24	BEARING CUP				
30	0702-370	2	HUB 14" 8 BOLT MACHINED				
31	2035-479	12	PLUG 1/8" NPT HEX CS				
32	0702-368	12	SEAL LIP				
33	0702-364	12	WASHER HARD .25 x 2.125 x .935				
34	2035-595	12	NUT HEX JAM LOCK 7/8-9 UNC GR C				
35	0702-644	12	CAP, HUB				
36	0702-371	12	SNAP RING .093 x .3.25				
37	0702-264	2	WHEEL 14" W/PLATE				
38	0090-136	96	WASHER HARD 1.0 X .531 X .197				
39	2035-659	96	CAPSCREW HH 1/2-13 x 1.375 GR8				
40	0702-615	2	ASSEMBLY HUB 14" W/RUBBER WHEEL				

ASV P/N: 0702-560 includes items: 25-29, 31-32 & 41
ASV P/N: 0702-569 includes items: 25-32

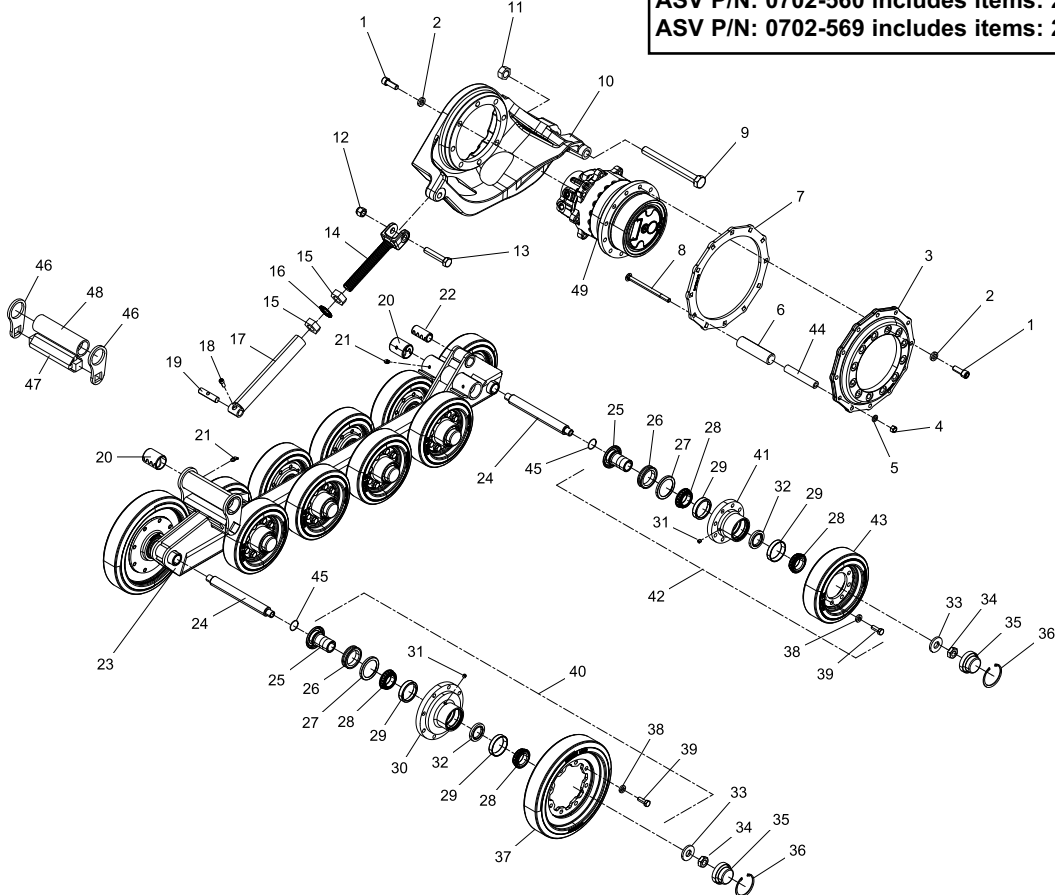

TRACK INSTALLATION TOOL

RT- 60 valid from - 00600
R190T valid from - 00300

Chapter 5

REF. NO.	PART NUMBER	QTY.	DESCRIPTION
1	0702-170	1	ASSY,INSTALLATION,TRACK
2	0702-171	1	WLMT,HOOK,TRACK
3	8102-235	1	CAPSCREW,HH,3/8-16UNCx4.5,GD8,
4	8102-232	1	CAPSCREW,HH,3/8-16,UNCx3.25,GD
5	0702-175	1	WLMT,TRACK,HANDLE
6	0702-143	1	CAP,3/4-10
7	0702-180	1	WLMT,CATCH,TRACK
8	8040-486	2	NUT,HEX,NYLOCK,3/8-16 UNC,ZN
9	0702-219	1	INSERT,WHEEL

REF. NO.	PART NUMBER	QTY.	DESCRIPTION

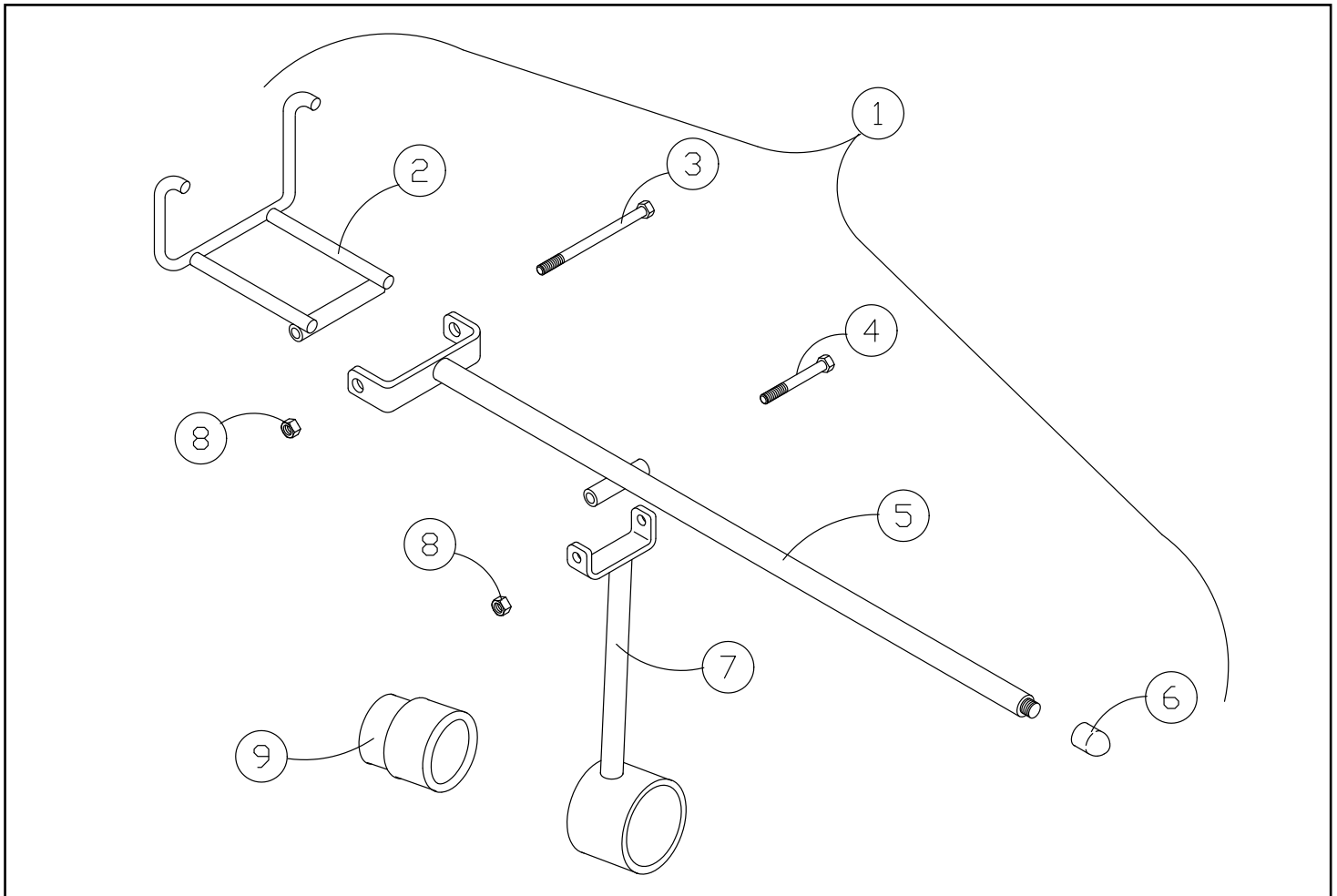

Chapter 6

Mainframe

6-1 Chassis Assembly

RT-60 Serial # valid from - 00600.6-1A

R190T Serial # valid from - 00300.6-1A

6-2 Hood Assembly

RT-60 Serial # valid from - 00600.6-2A

R190T Serial # valid from - 00300.6-2A

- * **Parts manuals are updated on a regular basis. Always refer to the current online version to ensure you have the most up to date information prior to ordering parts.**

NOTE: Ordering parts that are painted requires a specific part number format. Please refer to page II of this manual for paint code and ordering information.

CHASSIS ASSEMBLY

RT- 60 valid from - 00600
R190T valid from - 00300

Chapter 6

REF. NO.	PART NUMBER	QTY.	DESCRIPTION	REF. NO.	PART NUMBER	QTY.	DESCRIPTION
1	8050-222	11	WASHER,WROUGHT,1/4,STD,ZN	41	8051-242	4	WASHER,SPRING LOCK,5/16,ZN
2	8040-606	27	NUT,HEX,NYLOCK,1/2-13 UNC,ZN	42	2030-780	1	MNT PILOT GEN
3	8102-042	5	CAPSCREW, HH 1/4-20UNC 1" GD8	43	8050-262	2	WASHER,WROUGHT,5/16,STD,ZN
4	0200-139	1	PLATE, SKID, REAR	44	8040-426	2	NUT,HEX,NYLOCK,5/16-18 UNC,ZN
5	8050-262	26	WASHER,WROUGHT,5/16,STD,ZN	45	8011-132	2	BOLT,CARRIAGE,5/16-18 UNCx1.0,
6	2030-188	2	FOAM,LOADER LOCK,15 1/2"	46	2030-831	2	PLATE, WASHER, WEIGHT
7	0090-003	2	NUT,WELD,HEX,5/16-18	47	0200-140	1	SCREEN,BACK,CHASSIS
8	0090-138	2	SCREW CAP HSFH 5/16-18 X .75 BLK ZC	48	8102-132	2	CAPSCREW,HH,5/16-18UNCx1.0 GD8 ,ZN
9	0200-134	1	PLATE,SKID,FRONT	49	8050-262	4	WASHER,WROUGHT,5/16,STD,ZN
10	8102-222	24	CAPSCREW,HH,3/8-16 UNCx1.0,GD8	50	4010-178	1	DECAL BATTERY SHUTOFF
11	8051-272	24	WASHER,SPRING LOCK,3/8,ZN	51	2030-768	1	PLATE MOUNTING SWITCH
12	2030-814	1	WLMT CHASSIS	52	8040-426	2	NUT,HEX,NYLOCK,5/16-18 UNC,ZN
13	2030-154	1	LOCK,LOADER,REMOVABLE	53	0404-324	1	SWITCH
14	0201-477	2	PIN,LOCKING,D-RING,3.00"				
15	2030-109	2	WEIGHT,REAR,SIDE				
16	2030-316	1	BRACKET, FUEL DOOR				
17	0310-423	2	PLUG,STEEL,3.00"				
18	8102-406	8	CAPSCREW,HH,1/2-13UNCx1.75,GD8				
19	0201-066	2	PLATE,BOLT				
20	2030-317	1	WLMT DOOR ARM				
21	0201-483	4	BOLT,PLOW,1/2-13x2.00				
22	0200-179	1	PLATE,SKID,CENTER				
23	2030-320	1	SPRING EXTENSION 2.36"				
24	0090-139	2	BUSHING PLASTIC .5 OD X .38 ID				
25	0090-137	2	SCREW SHOULDER-HSH 5/16-18 X 1.00				
26	8102-040	13	CAPSCREW,HH,1/4-20 UNCx.75,GD8				
27	0200-140	1	SCREEN,BACK,CHASSIS				
28	4046-088	1	CAP FUEL YELLOW				
29	8102-416	4	CAPSCREW HH 1/2-13 x 5 GD 8				
30	8051-212	10	WASHER,SPRING LOCK,1/4,ZN				
31	0200-105	1	PLATE,ENGINE,SURROUND				
32	2030-809	1	WEIGHT,REAR				
33	0200-167	4	WEIGHT				
34	8102-416	4	CAPSCREW,HH,1/2-13 UNCx5.5,GD8				
35	8050-347	24	WASHER,WROUGHT,1/2,STD,ZN				
36	0200-437	2	PLUG,HOLE,6"				
37	0310-467	1	CLAMP,WIRE,1.0				
38	0302-537	1	SCREW,SELF-TAPPING				
39	8102-128	4	CAPSCREW,HH 5/16-18UNCx7/8 GR8 ZN				
40	2030-584	1	FIREWALL				

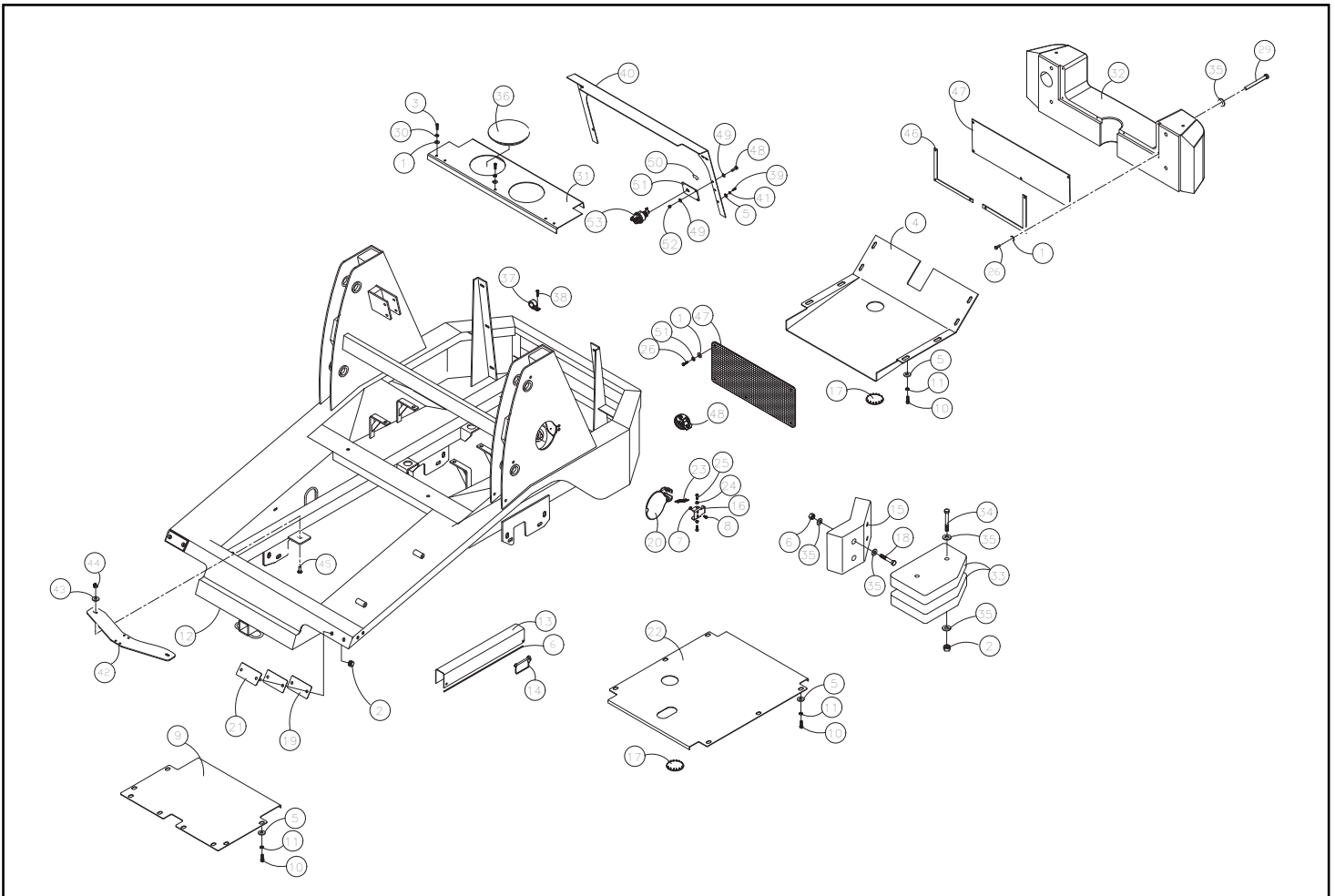

HOOD ASSEMBLY

RT- 60 valid from - 00600
R190T valid from - 00300

Chapter 6

REF. NO.	PART NUMBER	QTY.	DESCRIPTION	REF. NO.	PART NUMBER	QTY.	DESCRIPTION
1	0302-042	2	LATCH,RUBBER,T-HANDLE				
2	8060-731	4	RIVET,STAINLESS,3/16x.575				
3	8060-688	4	RIVET,BLIND,3/16 x .375 ABA				
4	0302-965	4	WASHER,RIVET,#7				
5	2040-057	1	WLMT SCREEN REAR				
6	8040-366	15	NUT,HEX,NYLOCK,1/4-20 UNC,ZN				
7	8102-038	13	CAPSCREW,HH 1/4-20UNCx7/8 GRD8				
8	2030-444	1	WLMT HOOD RT60 (WHITE)				
9	2045-284	1	WLMT SCREEN TOP				
10	2045-647	1	HANDLE LIFT HOOD				
11	0310-648	2	SCREW,MACH,1/4-20UNCx1.25				
12	2030-445	1	WLMT COWL				
13	0314-269	4	NUT,FLANGE,TOPLK,3/8-16UNC,GDG,ZN				
14	2030-457	2	WLMT HINGE RH				
15	8011-224	4	BOLT CARRAIGE 3/8-16 UNC X 1.0 ZN				
16	8102-226	2	CAPSCREW,HH 3/8-16UNCx1.75 GD8				
17	8040-486	2	NUT,HEX,NYLOCK,3/8-16 UNC,ZN				
18	0304-495	4	STUD,BALL,10MM STUD				
19	2040-110	2	SPRING GAS 100 LB				
20	8040-426	5	NUT,HEX,NYLOCK,5/16-18 UNC,ZN				
21	8050-262	5	WASHER,WROUGHT,5/16,STD,ZN				
22	8051-242	5	WASHER,SPRING LOCK,5/16,ZN				
23	8102-134	5	CAPSCREW,HH,5/16-18UNCx1.25GD8				
24	2040-165	1	TRIM HOOD 140"				
25	2030-458	2	WLMT HINGE LH				
26	2030-389	1	HOOD LOCK HOOK				
27	2030-388	1	PAWL SOUTHCO				
27	2030-387	1	LOCK SOUTHCO				

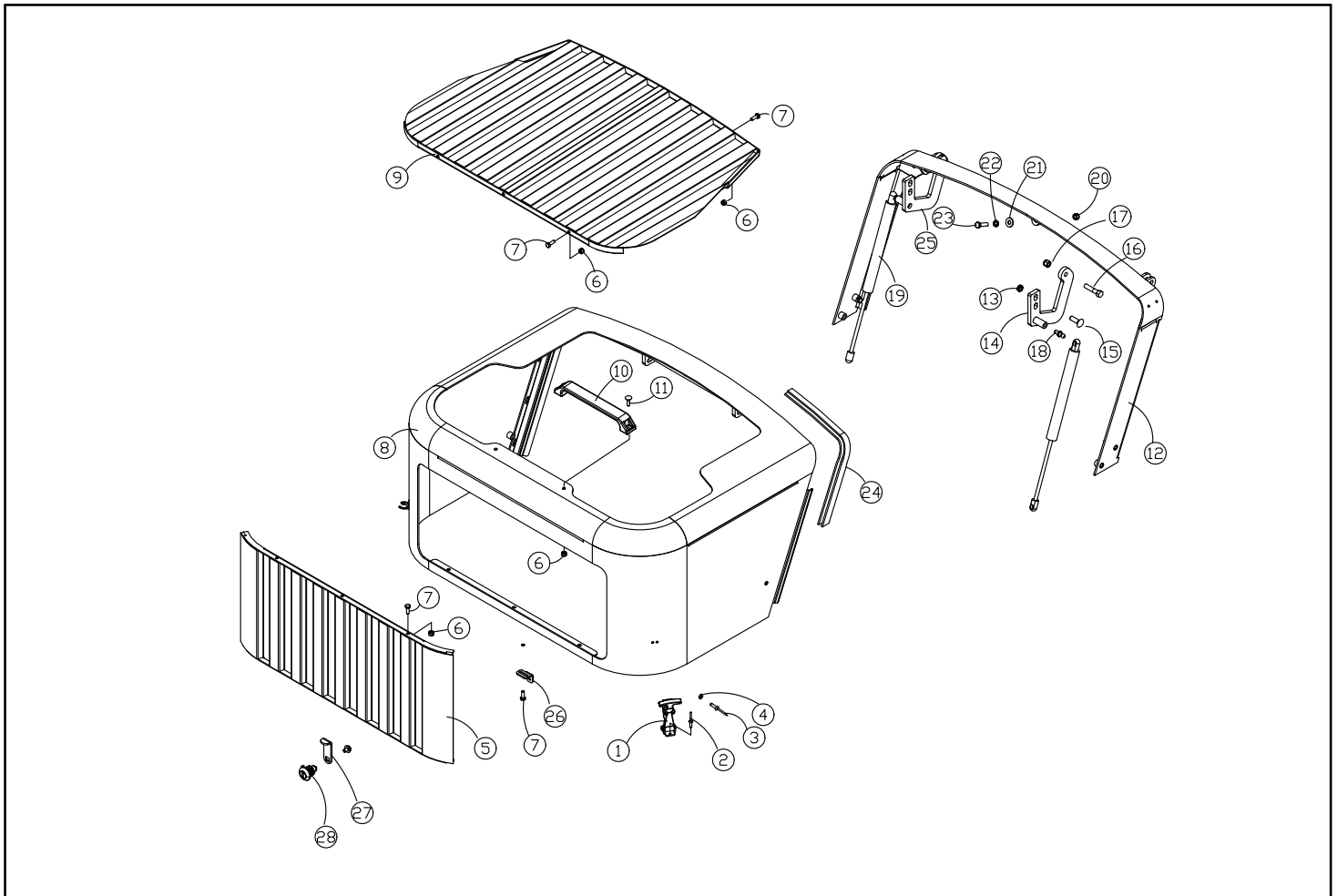

Chapter 7

Cab / Heating / Air Conditioning

7-1 Cab Assembly

RT-60 Serial # valid from - 00600.7-1A

R190T Serial # valid from - 00300.7-1A

7-2 Enclosed Cab Assembly

RT-60 Serial # valid from - 00600.7-2A

R190T Serial # valid from - 00300.7-2A

7-3 Cab Heater Assembly

RT-60 Serial # valid from - 00600.7-3A

R190T Serial # valid from - 00300.7-3A

7-4 Cab Heat / Air Conditioning Assembly

RT-60 Serial # valid from - 00600.7-4A

R190T Serial # valid from - 00300.7-4A

- * **Parts manuals are updated on a regular basis. Always refer to the current online version to ensure you have the most up to date information prior to ordering parts.**

NOTE: Ordering parts that are painted requires a specific part number format. Please refer to page II of this manual for paint code and ordering information.

CAB ASSEMBLY

RT- 60 valid from - 00600
R190T valid from - 00300

Chapter 7

REF. NO.	PART NUMBER	QTY.	DESCRIPTION
1	0304-318	1	BOX,OWNERS MANUAL
2	2030-356	1	ROD, THREADED, 1/4-28 X 6.5"
3	8040-396	1	NUT,HEX,NYLOCK,1/4-28 UNF,ZN
4	8041-500	1	NUT,HEX,NYLOCK,3/8-16 UNC,THIN
5	0200-701	2	MOUNT, JOYSTICK
6	0304-496	1	PAD,SKID
7	0200-588	1	CONSOLE RH
8	0200-587	1	CONSOLE LH
9	0302-546	1	KNOB,PLASTIC,1-7/8 DIA,1/2-13
10	0314-269	6	NUT,FLANGE,TOPLK,3/8-16UNC,GDG,ZN
11	8050-157	1	WASHER,WROUGHT, #10 3/16,STD,ZN
12	8040-486	1	NUT,HEX,NYLOCK,3/8-16 UNC,ZN
13	2030-357	1	WASHER COMPOSITE
14	0304-485	5	SCREW,MACH,10-24x3/4,STAINLESS
15	0090-011	4	SCREW OH PH #10 x 1.25 SS
16	0090-010	4	NUT SPEED #10
17	8102-222	6	CAPSCREW,HH,3/8-16 UNCx1.0,GD8,ZN
18	0200-291	1	INSULATION,MIDDLE
19	0200-328	1	PLATE,FIREWALL
20	0200-264	1	HOUSING,POWER SOURCE
21	0304-579	6	PLUG,HOLE,PLASTIC,5/16
22	0201-912	1	LEVER,THROTTLE
23	0314-215	1	CONNECTOR,JOINT,BALL
24	0301-121	2	NUT,JAM,1/4-28 UNF
25	0090-012	8	WASHER FINISHING #10 SS
26	0307-606	4	PLUG,FINISHING,STEEL,1-3/8"
27	0200-292	1	INSULATION,BOTTOM
28	0304-466	1	STOP,LAPBAR
29	8050-240	10	WASHER,STAINLESS,1/4",MS
30	0304-465	4	CAPSCREW,HH,M6-1.0x16mm
31	0304-467	1	BRKT,LAPBAR
32	8040-606	4	NUT,HEX,NYLOCK,1/2-13 UNC,ZN
33	0304-468	2	RING,SNAP,LAPBAR
34	8102-404	4	CAPSCREW,HH 1/2-13UNCx1.25 GD8
35	0304-469	1	LAPBAR
36	0304-470	1	MNT,LAPBAR
37	0304-477	2	SPACER,LAPBAR
38	0304-471	2	SPRING,GAS,ASSIST
39	0304-472	1	MNT,LAPBAR,SWITCH
40	0304-476	1	GROMMET,RUBBER

REF. NO.	PART NUMBER	QTY.	DESCRIPTION
41	0304-473	1	SENSOR,SWITCH,LAPBAR
42	0310-307	1	SCREW,MACHINE,4-40x.50 92314A110
43	0412-036	1	BRACKET LAP BAR ACTIVATION SWITCH
44	8011-227	1	BOLT,CARRIAGE,3/8-16 UNC x 2.0
45	0304-019	1	ASSY,LAP BAR
46	0304-400	6	CLIP,FASTENER
47	2030-511	1	WLMT ROPS 30/50/60
48	0301-637	1	GROMMET (1840)
49	0304-247	1	LIGHT,REAR
50	2030-360	1	BELLEVILLE WASHER, 3/8" ID X 1-1/8 OD
51	0200-320	2	WLMT,STOP LAP BAR
52	0200-321	2	PAD,RUBBER,W/ADHESIVE
53	8102-044	5	CAPSCREW,HH,1/4-20UNCx1.25,GD8
54	8051-212	5	WASHER,SPRING LOCK,1/4,ZN
55	0200-290	1	INSULATION, TOP
56	0201-902	1	CLEVIS,1/4-28,W/PIN
57	0200-288	1	BULB,HALOGEN
58	0201-867	1	BUSHING
59	0310-308	1	NUT,HEX,NYLOCK 4-40,91831A005
60	0201-903	1	SPRING,1.75X0.48
61	0301-033	1	WASHER,FENDER,1/4 x 1 1/4,STL,
62	2030-358	1	BRACKET FOOT THROTTLE
63	8050-282	3	WASHER,WROUGHT,3/8,STD,ZN
64	8102-227	2	CAPSCREW,HH,3/8-16UNCx2.0 GD8
65	0201-865	1	BUSHING,FOOT PEDAL
66	0201-925	1	WLMT,PEDAL
67	8102-040	4	CAPSCREW,HH,1/4-20 UNCx.75,GD8 ZN
68	0090-325	4	WASHER 3/4"-5/16" RUBBER BONDED
69	8050-222	4	WASHER,WROUGHT,1/4,STD,ZN
70	8040-366	4	NUT,HEX,NYLOCK,1/4-20 UNC,ZN

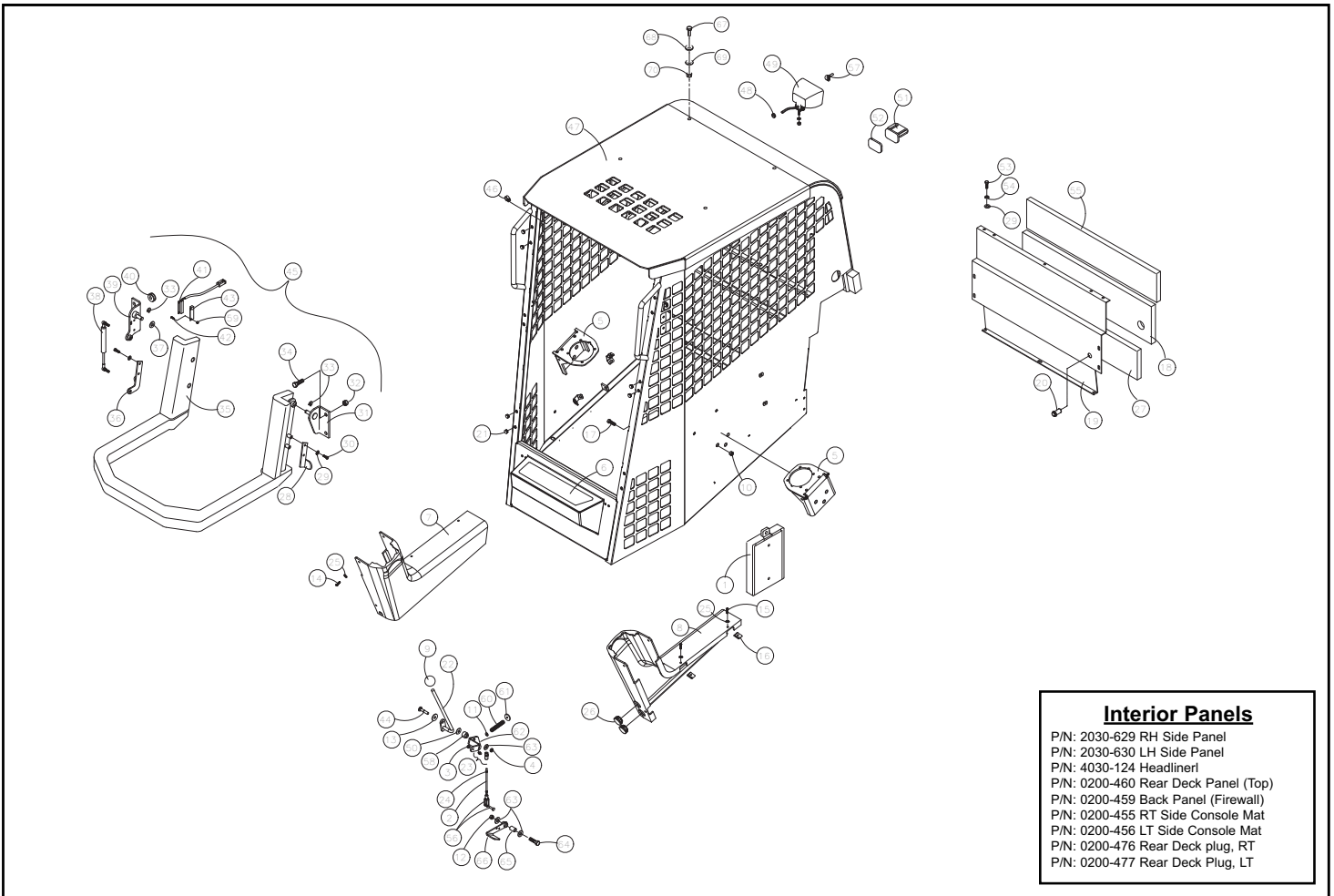

ENCLOSED CAB ASSEMBLY

RT- 60 valid from - 00600
R190T valid from - 00300

Chapter 7

REF. NO.	PART NUMBER	QTY.	DESCRIPTION
1	0403-762	2	WINDOW UPPER CORNER
2	0402-769	1	GLASS,SLIDER,SINGLE,RH
3	0403-763	2	WINDOW LOWER CORNER
4	2075-406	1	HANDLE PUSH BUTTON
5	0403-503	2	BUSHING,HINGE
6	2075-409	1	MOUNT DOOR LATCH
7	8040-426	8	NUT,HEX,NYLOCK,5/16-18 UNC,ZN
8	0304-619	1	MOTOR,WIPER,85^
9	0310-495	12'	STRIP,LOCK
10	0304-674	1	SEAL,WINDOW,10FT
11	0402-243	1	ARM,WIPER,15-19"
12	0304-557	1	BLADE,FLAT,14"
13	4030-106	1	WINDOW DOOR RT30/60 CE
14	8102-040	4	CAPSCREW,HH,1/4-20 UNCx.75,GD8
15	8050-222	4	WASHER,WROUGHT,1/4,STD,ZN
16	8040-426	2	NUT,HEX,NYLOCK,5/16-18 UNC,ZN
17	0304-495	2	STUD,BALL,10MM STUD
18	0304-484	11'	TRIM,CAB
19	2030-348	1	MOUNT SPRING
20	8050-240	1	WASHER,STAINLESS,1/4",MS
21	0304-486	1	CAPSCREW,HH,M6-1.0x14
22	0403-481	2	ASSY HINGE DOOR CAST LH
23	2075-408	1	STRIKE
24	0090-059	2	SCREW MACHINE #10 x .63 PH SELF DRILLING
25	8102-136	6	CAPSCREW,HH,5/16-18x1.75 ZN GD
26	0403-848	1	LATCH ARM RH
27	2075-407	1	HANDLE INSIDE
28	2075-416	1	MOUNT STRIKE
29	0403-733	1	HARNES,DOOR
30	0090-135	1	NUT NYLOCK M12 X 1.0 ZC
31	0304-573	1	HARNES,WIPER,B
32	0403-630	1	SPRING DAMPENED DOOR
33	0090-167	4	TIE CABLE MOUNT
34	8102-135	2	CAPSCREW,HH,5/16-18x1.50ZN,GD8
35	0200-607	1	SEAL PANEL ROOF
36	8102-042	32	CAPSCREW, HH 1/4-20UNC 1" GD8
37	2030-511	1	ROPS RT30/50/60
39	0310-495	5	STRIP,LOCK
38	0201-748	1	ASSY,TAG,EMERGENCY EXIT
40	1059-015	5	SEAL,WINDOW

REF. NO.	PART NUMBER	QTY.	DESCRIPTION
41	0403-842	1	WINDOW REAR
42	0402-758	1	GLASS,SLIDER,SINGLE,LH
43	0403-854	1	CATCH WINDOW RH
44	0090-304	1	KNOB STAR 1.75" RED M6 X 1.1 X 6MM
45	0403-767	1	SEAL RH UPPER WINDOW
46	8050-222	5	WASHER,WROUGHT,1/4,STD,ZN
47	8051-212	5	WASHER,SPRING LOCK,1/4,ZN
48	8050-262	8	WASHER,WROUGHT,5/16,STD,ZN
49	0090-272	7'	SEAL V-PROFILE 15MM X 16MM
50	0403-847	1	LATCH ARM LH
51	0403-913	1	T-HANDLE NON LOCKING
52	0403-845	1	WLMT FRAME WINDOW REAR
53	0403-850	2	HINGE REAR WINDOW MALE
54	0403-846	1	T-HANDLE LOCKING
55	8061-604	5	RIVET,ALUMINUM,3/16x.575
56	0314-528	1	MOUNT GAS SPRING BALL 10MM
57	2045-503	1	SPRING GAS ASSIST
58	0200-552	1	MNT,BRACKET,BALLSTUD
59	0200-545	4	CLIP,SAFETY,GAS SPRING
60	0200-606	1	PANEL ROOF LEXAN
61	0403-478	1	WLMT,DOOR,W/HINGES (SEE NOTE)
62	0403-766	1	SEAL LH UPPER WINDOW
63	0403-853	1	CATCH WINDOW LH
64	0403-764	1	SEAL LH UPPER WINDOW
65	0403-765	1	SEAL LH LOWER WINDOW
66	8102-039	5	CAPSCREW,HH,1/4-20UNCx.625,GD8
67	2010-592	1	DECAL EMERGENCY EXIT ANSI
68	0090-347	10	SCREW TH PH 1/4-20 X 1.25 ZN
69	0090-622	1	MACH, PH PAN HD, M6-1.0 X 10MM CLR ZNC

For kit information, please see page 10-1A

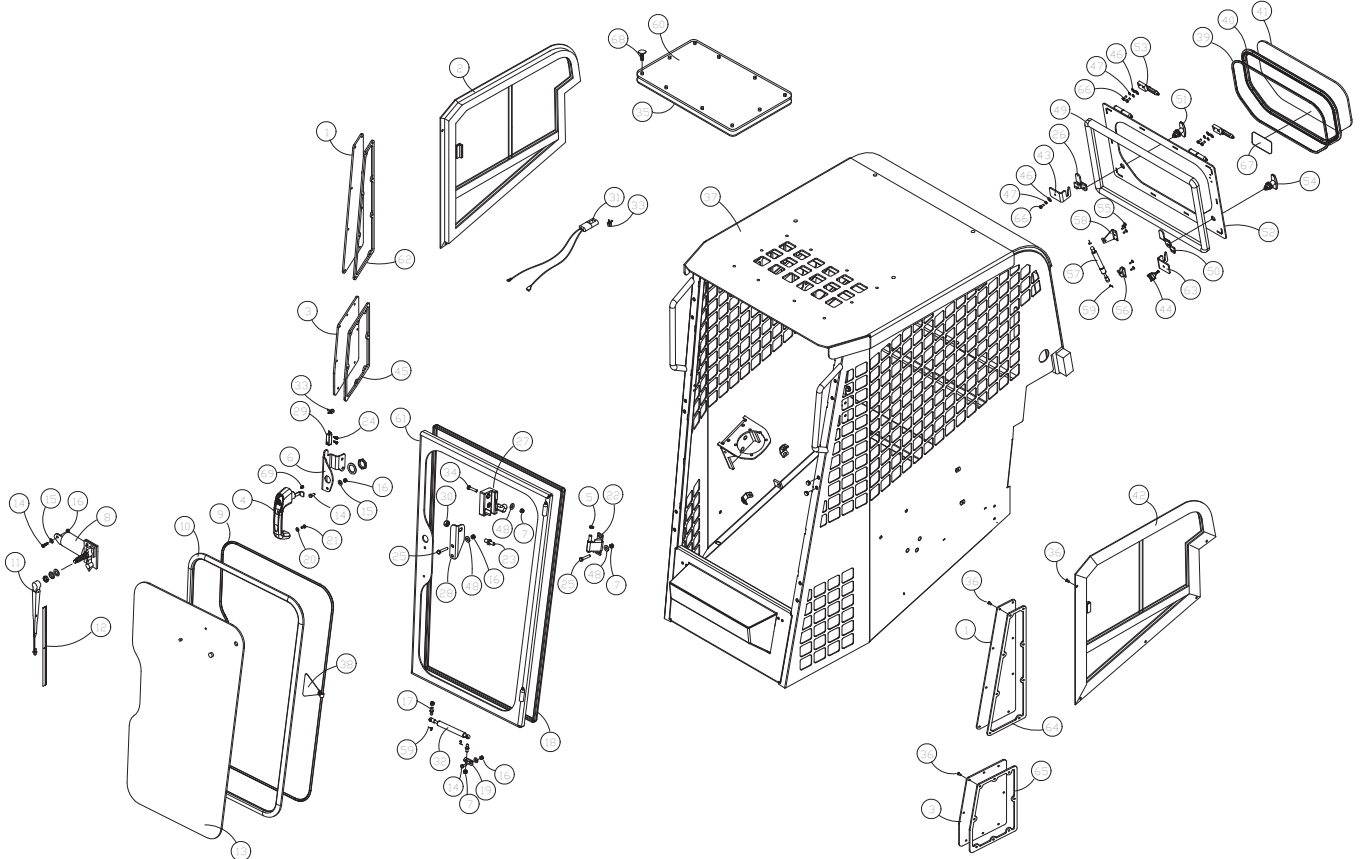

CAB HEATER ASSEMBLY

RT- 60 valid from - 00600
R190T valid from - 00300

Chapter 7

REF. NO.	PART NUMBER	QTY.	DESCRIPTION	REF. NO.	PART NUMBER	QTY.	DESCRIPTION
1	0304-546	1	HEATER,CAB, RC-30				
2	0304-548	2	MNT,HEATER				
3	0305-214	1	HOSE,HEATER,5/8 x 33"				
4	0304-553	1	HOSE,HEATER,5/8,72"				
5	0304-554	1	HOSE,HEATER,5/8,38"				
6	0301-558	1	VALVE,FLOW,HEATER				
7	0404-329	1	CABLE,PUSH-PULL,HEATER				
8	0301-514	1	KNOB,SWITCH,HEATER				
9	8102-038	2	CAPSCREW,HH 1/4-20UNCx7/8 GRD8				
10	8040-366	2	NUT,HEX,NYLOCK,1/4-20 UNC,ZN				
11	0301-654	1	NUT,JAM,3/8-24 UNF				
12	0301-110	6	CLAMP,HOSE,#8				
13	0310-838	1	CLAMP,TUBE,DOUBLE,1.0				
14	0304-670	1	ADAPTER,5/8BARB-3/8MRT-90^				
15	0304-570	1	ADAPTER,6MP-10HOSE,BARB				
16	0307-720	1	CAPSCREW,HH,M8x1.25x20				
17	8051-242	1	WASHER,SPRING LOCK,5/16,ZN				
18	8050-277	1	WASHER,WROUGHT,3/8,SAE,ZN				
19	0304-575	1	HARNES,HEATER				
20	0304-122	1	SWITCH,ON/OFF,HEATER				
21	0310-587	4	CLAMP,WIRE,3/8,ADHESIVE				
22	2045-748	2	GROMMET 1 3/8" HOLE				
23	8050-222	6	WASHER,WROUGHT,1/4,STD,ZN				
24	0310-713	1	GASKET, SWITCH				
25	8102-039	4	CAPSCREW,HH,1/4-20UNCx.625,GD8				
26	8051-212	4	WASHER,SPRING LOCK,1/4,ZN				

For kit information, please see page 10-1A

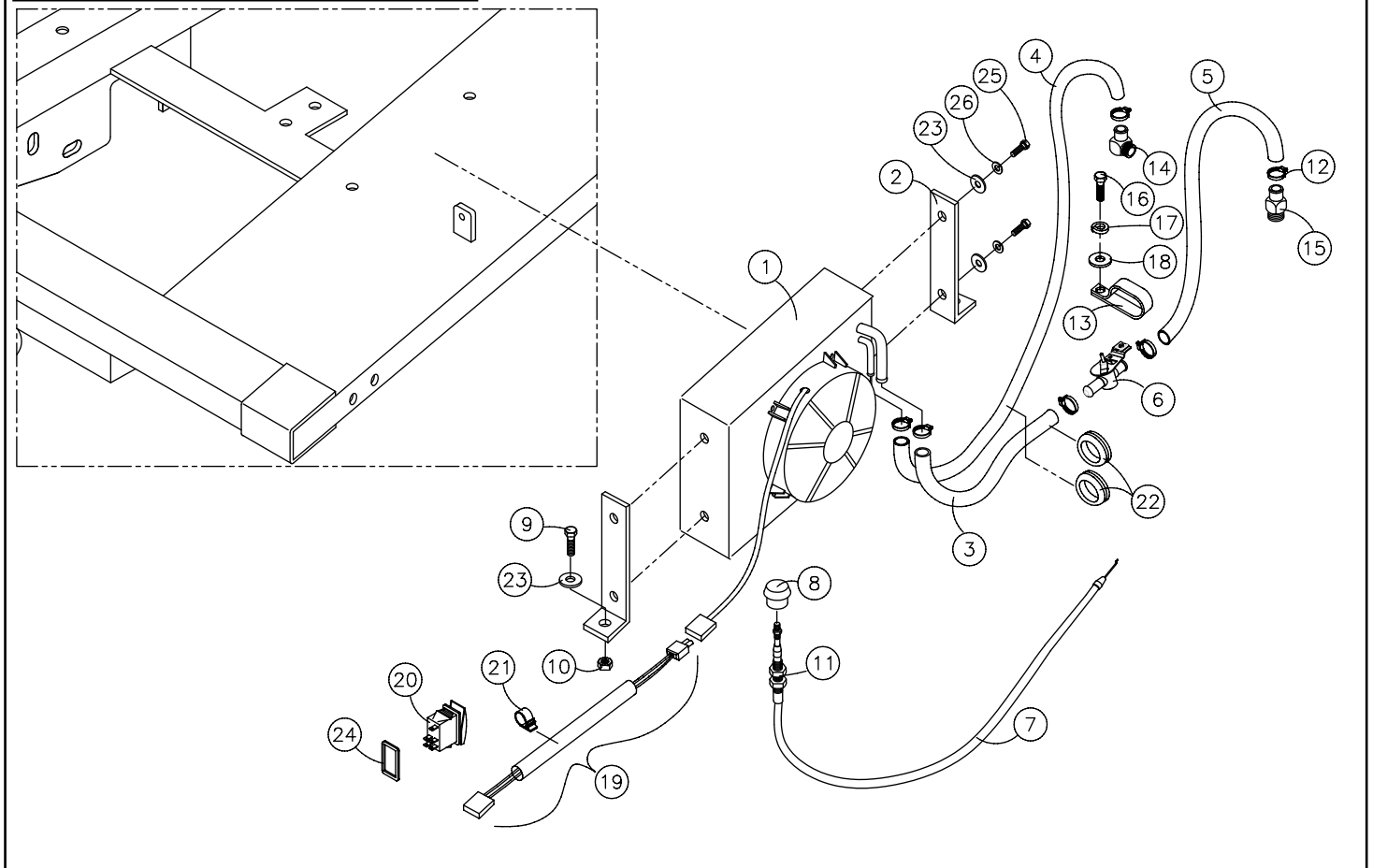

HEAT / AIR CONDITIONING ASSEMBLY

RT- 60 valid from - 00600
R190T valid from - 00300

Chapter 7

REF. NO.	PART NUMBER	QTY.	DESCRIPTION
1	8102-139	1	CAPSCREW,HH5/16-18UNCx2.50 GD8
2	8051-242	3	WASHER,SPRING LOCK,5/16,ZN
3	8050-222	1	WASHER,WROUGHT,1/4,STD,ZN
4	0201-573	1	SPACER,TUBE,.75x.5x1
5	0782-019	1	DRYER
6	0201-628	1	SPACER,CLAMP
7	0782-048	1	HOSE,A/C,#6,92.00"
8	0782-053	1	HOSE,A/C,#6,55.50"
9	0314-269	3	NUT,FLANGE,TOPLK,3/8-16UNC,GDG
10	8050-277	1	WASHER,WROUGHT,3/8,SAE,ZN
11	0782-083	1	WLMT,MNT,COMPRESSOR
12	8050-262	3	WASHER,WROUGHT,5/16,STD,ZN
13	8102-225	2	CAPSCREW,HH,3/8-16 UNCx1.5,GD8
14	8102-236	1	CAPSCREW,HH,3/8-16UNCx5.0 GD8,
15	8102-132	1	CAPSCREW,HH,5/16-18UNCx1.0 GD8
16	0200-507	1	SPACER,FAN,3024C,A/C
17	0200-508	1	PULLEY,ADDITIONAL,CRANKSHAFT,3
18	0304-670	1	ADAPTER,5/8BARB-3/8MRT-90
19	0782-049	1	HOSE,A/C,#10,98.50"
20	0782-052	1	HOSE,A/C,#8,64.80"
21	0782-038	1	COMPRESSOR,AC,RC
22	0201-645	1	BELT,V, A SERIES, 1/2 x 48.00
23	0782-088	1	RELAY,CONDENSER,12V
24	0782-078	1	COIL,CONDENSER
25	0782-070	1	MNT,CONDENSER,ROOFTOP
26	0301-558	1	VALVE,FLOW,HEATER
27	0782-066	1	VALVE,EXPANSION,905
28	0782-067	2	ASSY,BLOWER
29	0782-073	1	COVER,AC
30	0782-072	1	SWITCH,TOGGLE,AC
31	0782-082	2	KNOB
32	0782-075	1	CABLE,CONTROL
33	0782-037	3	LOUVER,A/C,PERRIN
34	0782-060	4	LOUVER,ROUND,AC,RC50
35	0782-085	1	ASSY,FAN
36	0782-069	2	RESISTOR
37	0782-068	1	THERMOSTAT,AC
38	0782-081	1	COVER,HOUSING
39	0782-089	1	ASSY,EVAPORATOR
40	0200-527	1	TEE,5/8,BARBED

REF. NO.	PART NUMBER	QTY.	DESCRIPTION
41	0782-065	2	ARM,TENSION,COMPRESSOR

For kit information, please see page 10-1A

COMPRESSOR ASSEMBLY

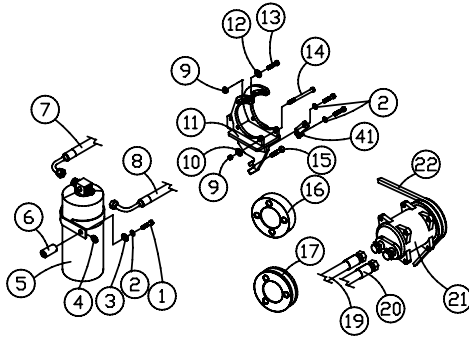

UPPER HOUSING ASSEMBLY

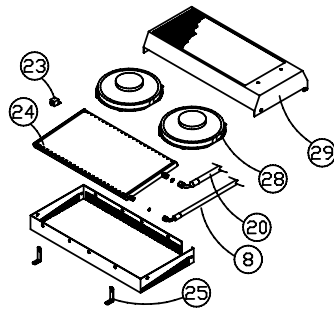

LOWER HOUSING ASSEMBLY

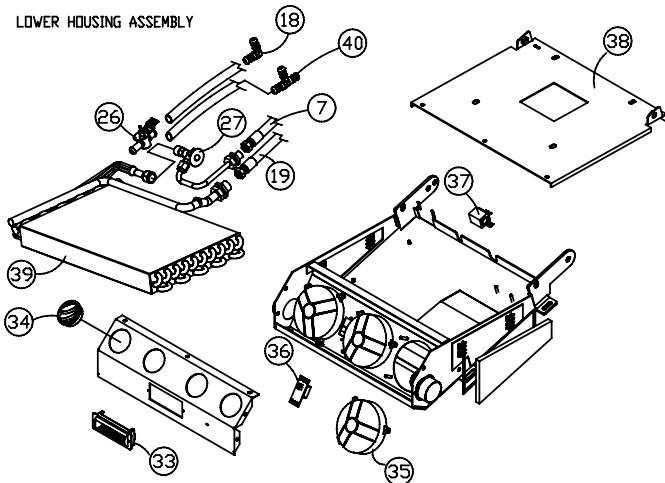

SIDE CONSOLE ASSEMBLY

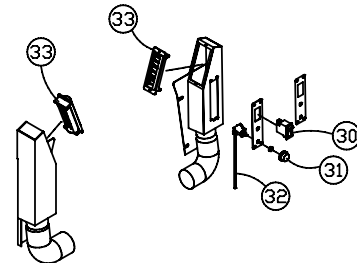

Chapter 8

Quick Attach

8-1 Manual Quick Attach Assembly

RT-60 Serial # valid from - 00600.8-1A

R190T Serial # valid from - 00300.8-1A

Hydraulic Quick Attach Assembly

RT-60 Serial # valid from - 00600.8-2A

R190T Serial # valid from - 00300.8-2A

- * **Parts manuals are updated on a regular basis. Always refer to the current online version to ensure you have the most up to date information prior to ordering parts.**

NOTE: Ordering parts that are painted requires a specific part number format. Please refer to page II of this manual for paint code and ordering information.

MANUAL QUICK ATTACH ASSEMBLY

RT- 60 valid from - 00600
R190T valid from - 00300

Chapter 8

REF. NO.	PART NUMBER	QTY.	DESCRIPTION	REF. NO.	PART NUMBER	QTY.	DESCRIPTION
1	2045-359	1	WLMT,QUICK-ATTACH,MANUAL				
2	2045-761	1	HANDLE,QA,LH				
3	2045-762	1	HANDLE,QA,RH				
4	2046-405	1	WLMT PIN RH				
5	2046-406	1	WLMT PIN LH				
6	2045-245	2	BLOCK LATCH				
7	8102-418	2	CAPSCREW,HH,1/2-13UNCx 6.0,GD8				
8	0090-002	2	BOLT,SHOULDER,5/8"x.625" GD 8				
9	8050-347	8	WASHER,WROUGHT,1/2,STD,ZN				
10	2015-018	2	WASHER,FENDER,1.75x0.53x0.125				
11	8051-620	6	WASHER,SPRING LOCK,1.0,ZN				
12	0400-621	2	SPOOL,PIVOT				
13	0304-799	2	CAPSCREW,HH,1/2-13UNCx3.75,GD8				
14	8040-606	2	NUT,HEX,NYLOCK,1/2-13 UNC,ZN				
15	0400-651	2	SPRING,COMPRESSION				
16	0300-607	2	ZERK,GREASE,1/4-28				

For kit information, please see page 10-1A

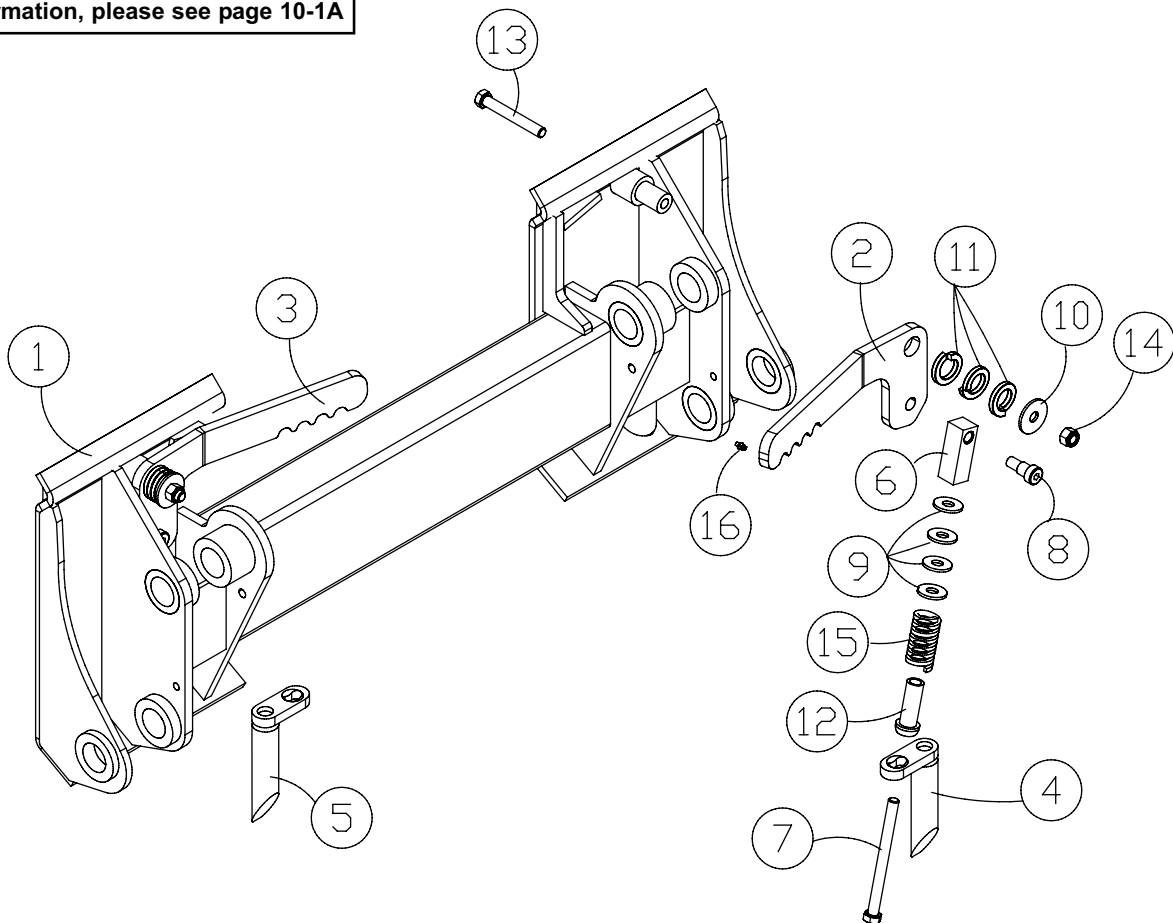

HYDRAULIC QUICK ATTACH ASSEMBLY (OPTIONAL)

RT- 60 valid from - 00600
R190T valid from - 00300

Chapter 8

REF. NO.	PART NUMBER	QTY.	DESCRIPTION	REF. NO.	PART NUMBER	QTY.	DESCRIPTION
1	7006-488	1	WLMT, GUARD, QA				
2	2046-316	1	CYLINDER QA LH				
3	2046-317	1	CYLINDER QA RH				
4	2045-235	1	WLMT QUICK-ATTACH HYD				
5	0201-566	1	HOSE, 6M4K-6FFORX90S-6FFORX-49.				
6	0201-545	1	HOSE, 6M4K-6FFORX-6FFORX90S-14.				
7	0201-565	1	HOSE, 6M4K-6FFORX90S-6FFORX-53.				
8	0201-544	1	HOSE, 6M4K-6FFORX-6FFORX90S-25.				
9	0310-328	2	ADAPTER, 6MFFOR-6MB-90				
10	0201-542	2	ADAPTER, TEE, 6FS-6FS-6NWO				
11	8102-412	2	CAPSCREW, HH 1/2-13UNCx3.25 GD8				
12	8102-686	1	CAPSCREW, HH, 3/4-10UNCx4.25 GD8				
13	8040-786	1	NUT, HEX, NYLOCK, 3/4-10 UNC, ZN				
14	2045-245	2	BLOCK LATCH				
15	2045-246	2	LATCH QA				
16	0090-001	2	BOLT, SHOULDER, 5/8"x1.25" GD 8				
17	8040-606	2	NUT, HEX, NYLOCK, 1/2-13 UNC, ZN				
18	8050-347	4	WASHER, WROUGHT, 1/2, STD, ZN				
19	0300-607	2	ZERK, GREASE, 1/4-28				
20	0400-651	2	SPRING, COMPRESSION PLATED				
21	0400-621	2	SPOOL, PIVOT				
22	2046-406	1	WLMT PIN LH				
23	2046-405	1	WLMT PIN RH				
24	8102-418	2	CAPSCREW, HH, 1/2-13UNCx 6.0, GD8				
25	0310-733	1	INSERT, CLAMP, TWIN, 75" T3075-PP				
26	0310-828	1	COVER, CLAMP, 3/4" TCP-T3				
27	8102-136	1	CAPSCREW, HH, 5/16-18x1.75 ZN GD				
28	8050-348	2	WASHER, 1/2, SAE, ZN 1.06 OD x .531 ID x .090				

For kit information, please see page 10-1A

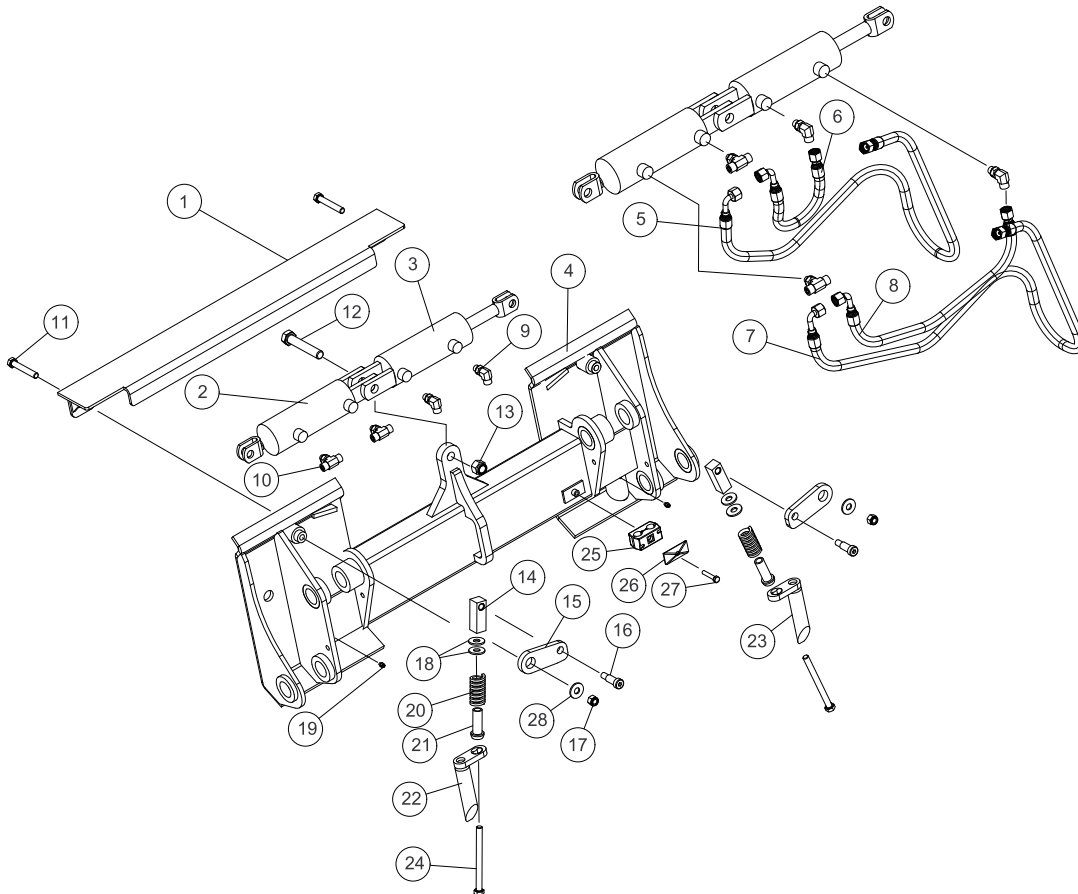

Chapter 9

Graphics / Safety Decals

9-1 Safety Decals U.S. (ANSI) (ASV / Terex)

RT-60 Serial # valid from - 00600. 9-1A

R190T Serial # valid from - 00300. 9-1A

9-2 Safety Decals ROW (ISO) (Terex only)

R190T Serial # valid from - 00300. 9-2A

9-3 Machine Graphics RT-60 (ASV)

RT-60 Serial # valid from - 00600. 9-3A

9-4 Machine Graphics R190T (Terex)

R190T Serial # valid from - 00300. 9-4A

- * **Parts manuals are updated on a regular basis. Always refer to current online posted manuals to ensure you have the most current information prior to ordering parts.**

SAFETY DECALS U.S. (ANSI)

RT- 60 valid from - 00600
R190T valid from - 00300

Chapter 9

REF. NO.	PART NUMBER	QTY.	DESCRIPTION	REF. NO.	PART NUMBER	QTY.	DESCRIPTION
1	2030-599	1	DECAL ANSI FIRE HAZARD (BRUSHCUTTING)				
2	0304-320	1	DECAL,OWNER'S MANUAL				
3	2030-594	2	DECAL ANSI LIFT ARM BRACE				
4	2030-602	2	DECAL ANSI SKIN INJECTION HAZARD				
5	4046-078	1	DECAL DIESEL FUEL ONLY				
6	2030-593	2	DECAL ANSI RUN OVER HAZARD				
7	2085-253	2	DECAL ANSI CLEAN UNDERCARRIAGES NOTICE				
8	2030-603	1	DECAL ANSI BATTERY EXPLOSION HAZARD				
9	2030-595	1	DECAL ANSI RADIATOR HAZARD				
10	2030-600	1	DECAL ANSI BELT FAN HAZARD				
11	2030-601	1	DECAL ANSI HOT SURFACES HAZARD				
12	4046-079	1	DECAL CE HYDRAULIC OIL ONLY				
13	0310-197	4	DECAL,TIE DOWN 156-5762				
14	0304-305	1	DECAL,THROTTLE				
15	2030-628	1	DECAL ANSI 2 SPEED				
16	2030-598	1	DECAL ANSI READ O&M ROLLOVER FALL HAZARD				
17	2030-596	1	DECAL ANSI ROLLOVER FALL HAZARD				
18	2030-424	1	DECAL CONTROLS RIGHT (NO TEXT)				
19	2030-423	1	DECAL CONTROLS LEFT (NO TEXT)				
20	2030-597	1	DECAL ANSI FALL HAZARD (3 POINT ENTRY)				
21	2030-592	2	DECAL ANSI LOADER CRUSH HAZARD				
22	7011-205	1	DECAL ANSI DANGER- FUELING				

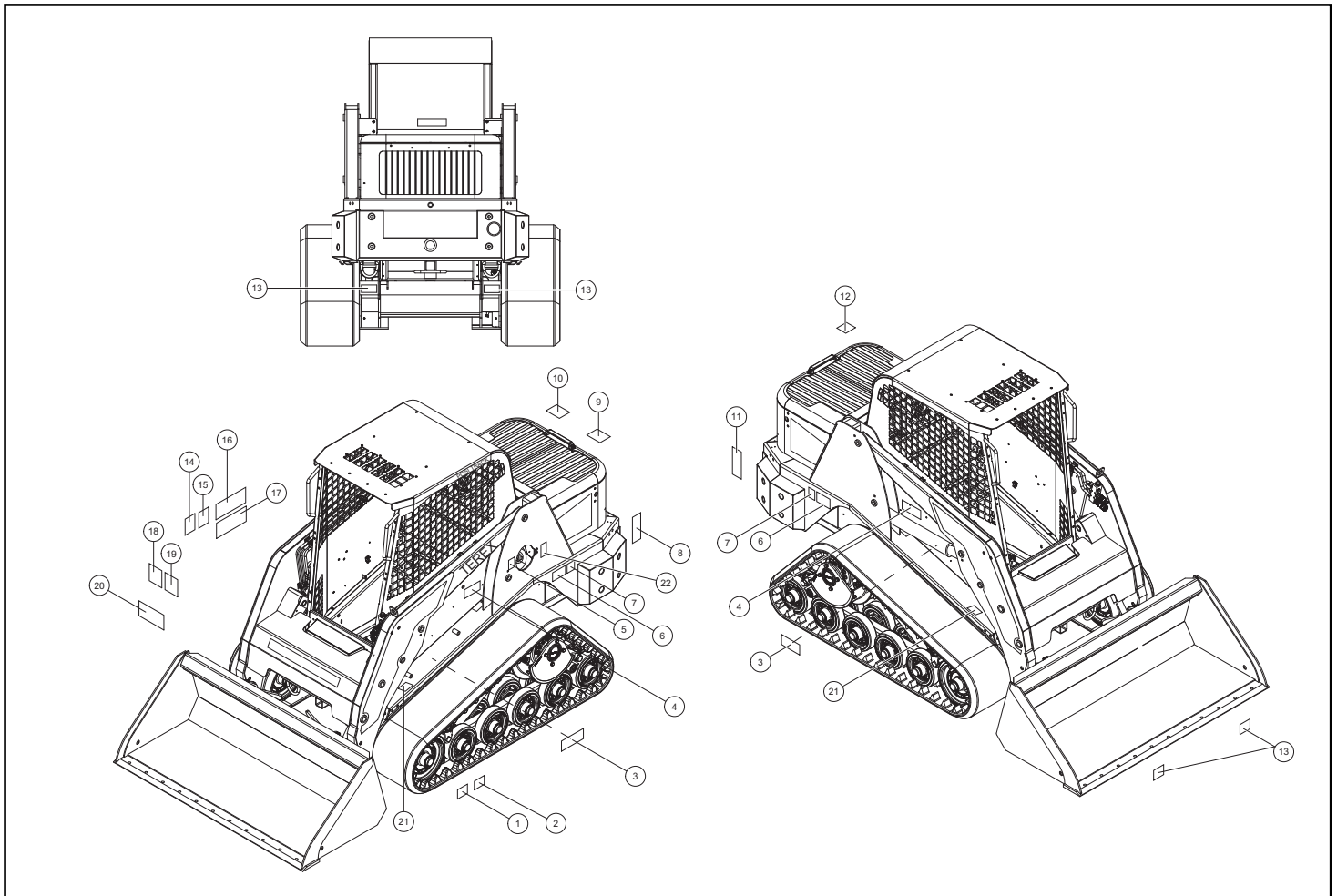

SAFETY DECALS R.O.W. (ISO)

RT- 60 valid from - 00600
R190T valid from - 00300

Chapter 9

REF. NO.	PART NUMBER	QTY.	DESCRIPTION	REF. NO.	PART NUMBER	QTY.	DESCRIPTION
1	2030-427	1	DECAL BRUSHCUTTING				
2	2030-422	1	DECAL MANUAL BOX (NO TEXT)				
3	2030-417	2	DECAL LOADER LOCK (NO TEXT)				
4	2030-553	2	DECAL ISO SAFETY SKIN OIL INJECTION				
5	4046-078	1	DECAL DIESEL FUEL ONLY				
6	2030-416	2	DECAL MOVING PARTS (TRACK WARNING)				
7	2030-415	2	DECAL BOOM CRUSH RT (NO TEXT)				
8	2030-565	1	DECAL ISO SAFETY BATTERY				
9	2030-418	1	DECAL ENGINE COMPARTMENT				
10	2030-551	1	DECAL ISO SAFETY FAN AND BELT				
11	2030-552	1	DECAL ISO SAFETY EXHAUST HOT				
12	4046-079	1	DECAL CE HYDRAULIC OIL ONLY				
13	0310-197	4	DECAL,TIE DOWN 156-5762				
14	2030-419	1	DECAL THROTTLE (NO TEXT)				
15	2030-428	1	DECAL 2 SPEED				
16	2030-426	1	DECAL NO RIDERS/WORK PLATFORM				
17	2030-420	1	DECAL CARRY LOADS/KEEP INSIDE				
18	2030-424	1	DECAL CONTROLS RIGHT (NO TEXT)				
19	2030-423	1	DECAL CONTROLS LEFT (NO TEXT)				
20	2030-425	1	DECAL 3 POINT (NO TEXT)				
21	0404-543	1	DECAL ISO ULSD FUEL HANDLING PRECAUTIONS				

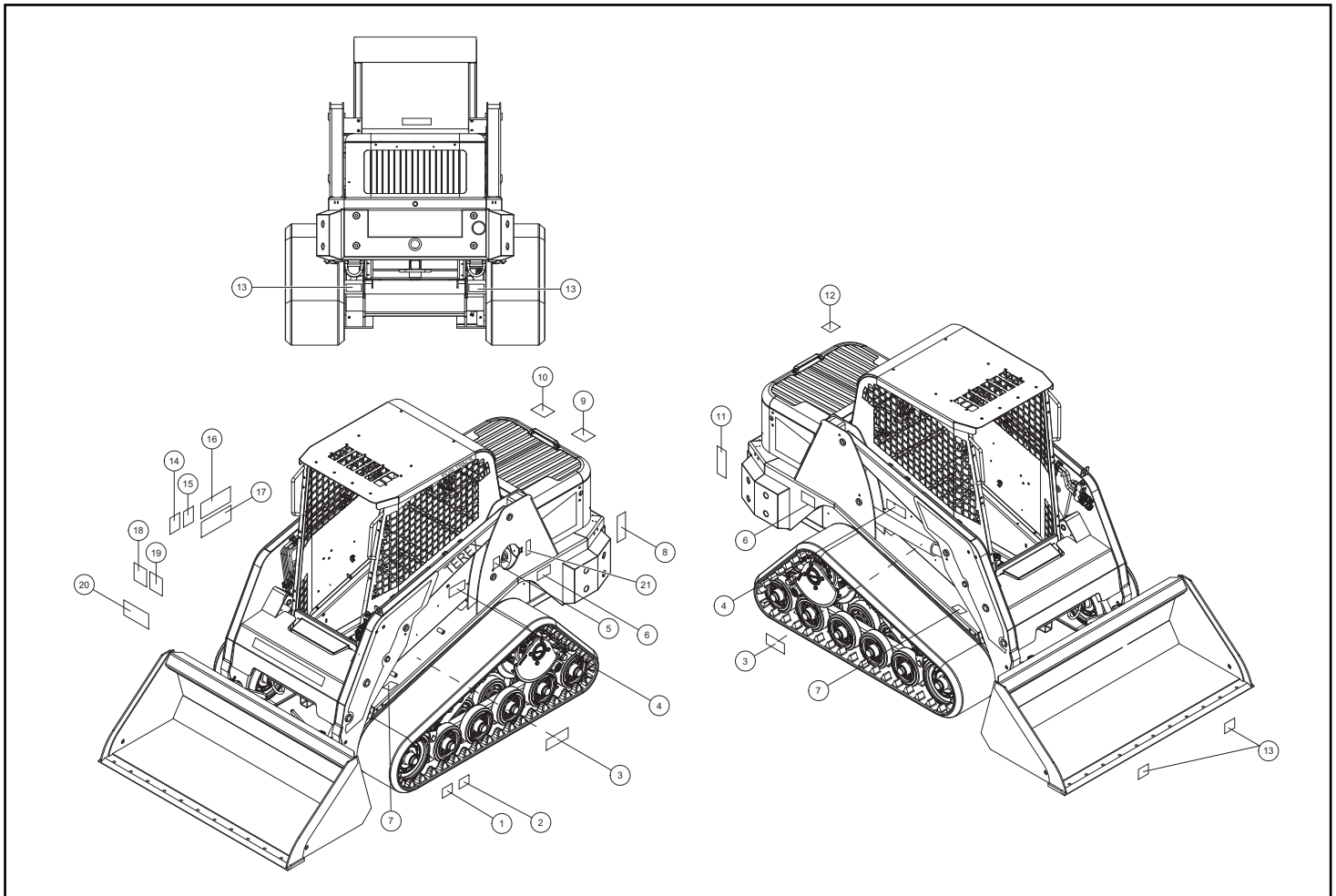

GRAPHICS RT-60 (ASV)

RT- 60 valid from - 00600

Chapter 9

REF. NO.	PART NUMBER	QTY.	DESCRIPTION
1	2030-902	1	DECAL LOADER FRONT
2	2030-901	2	DECAL ASV
3	2030-886	1	DECAL LOADER LH REAR
4	2030-887	1	DECAL LOADER LH FRONT
5	2030-884	1	DECAL LOADER RH REAR
6	2030-885	1	DECAL LOADER RH FRONT

REF. NO.	PART NUMBER	QTY.	DESCRIPTION

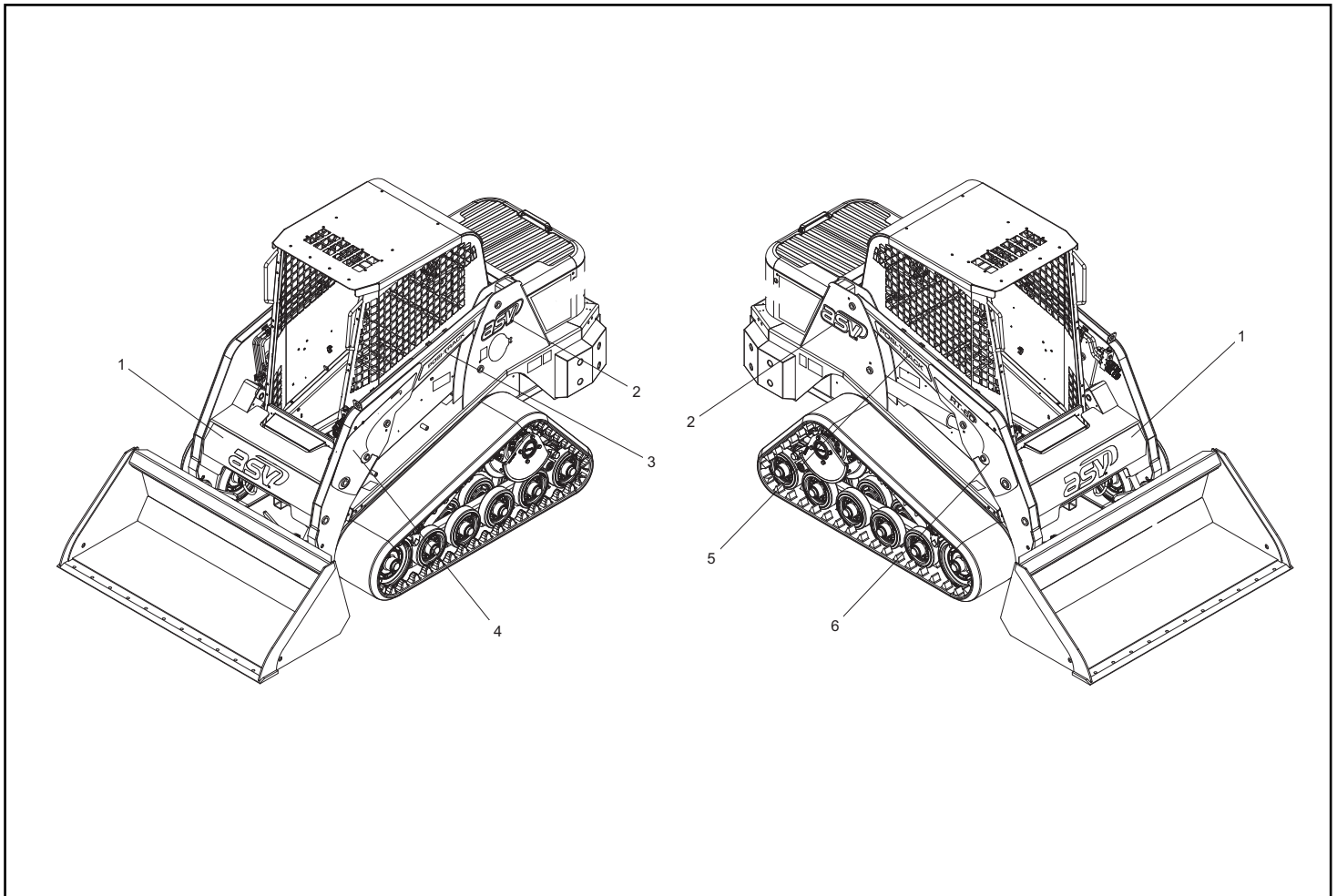

REF. NO.	PART NUMBER	QTY.	DESCRIPTION
1	2010-258	3	DECAL 2" TEREX
2	0090-582	2	DECAL R190T
3	2030-334	2	DECAL POSI TRACK
4	2075-965	2	DECAL ARM TEREX
5	2030-492	1	DECAL CROSS MEMBER BLACK TEREX
6	0090-615	2	DECAL GEN 2 BLACK

REF. NO.	PART NUMBER	QTY.	DESCRIPTION

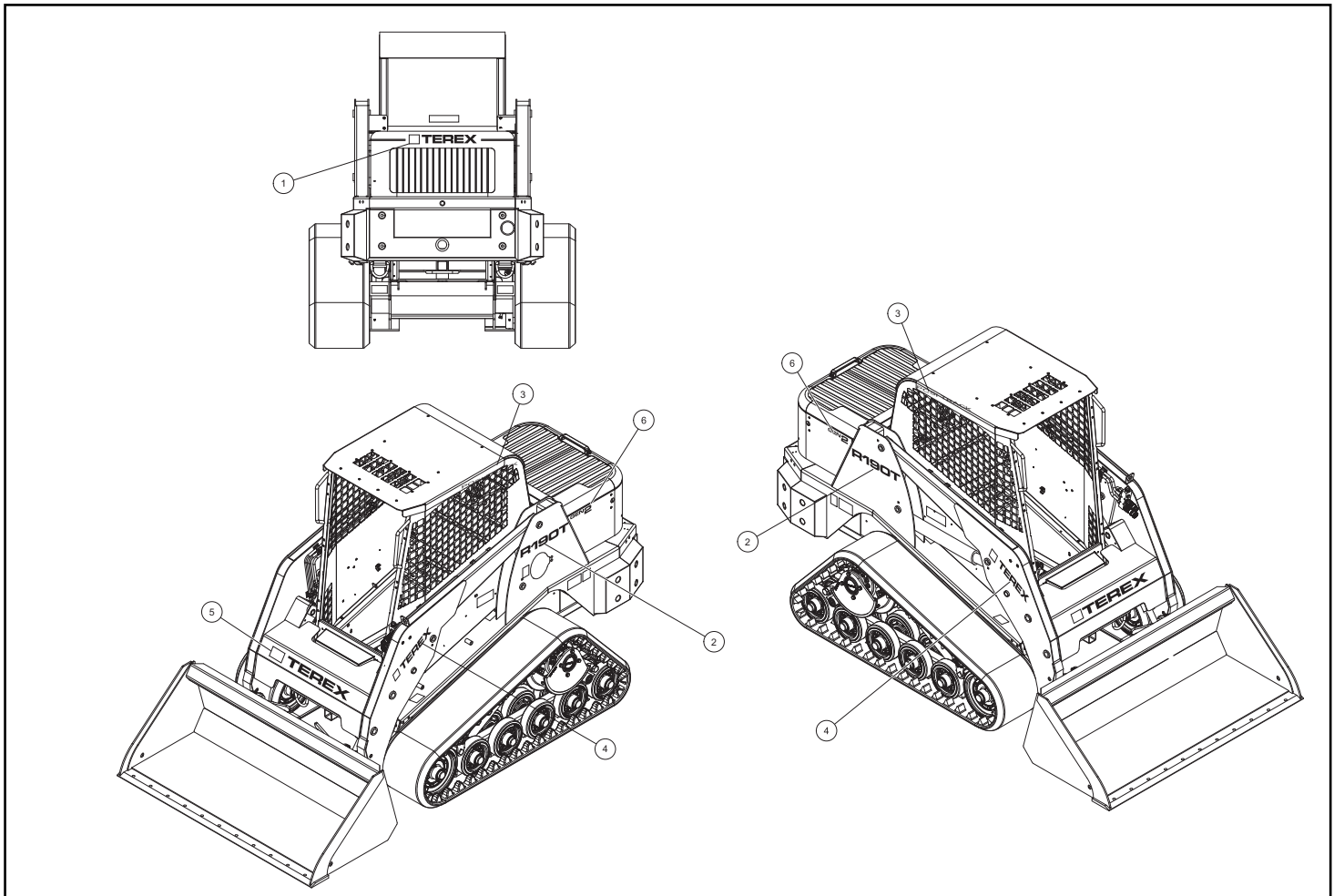

Kits

<u>Page</u>	<u>Kit</u>	<u>Part number</u>
2-2A	Tach and temp gauge kit	0403-543
3-4A	Complete valve seal kit	2010-777
3-4B	Complete valve seal kit	2010-777
3-5B	Complete seal kit for item 18	2046-409
5-2A	Complete seal kit for item 58	0403-871
5-3A	Complete seal kit for item 58	0403-871
7-2A	Std. Door Kit	0404-025
	Complete wiper kit	0404-016
	Complete side window kit	0404-032
7-3A	Complete heater kit	0404-021
7-4A	Complete AC / Heater kit	0404-029
8-1A	Manual QA assembly	0404-034
8-2A	Hydraulic QA field install kit	0403-542



ASV Holdings Inc.

840 Lily Lane

Grand Rapids, MN 55744

1-800-205-9913

www.asvi.com